

Hydraulics

S
C
h
y
d
r
a
u
n
i
c
s

Char-Lynn® Disc Valve Hydraulic Motors

11-01-878
EN-0201



2000, 4000, 6000, and 10,000 Series
Hydraulic Motors

We Manufacture

Solutions

Catalog of Disc Valve Hydraulic Motors from One of the World's Leading Manufacturers of Off Highway Mobile Components — Eaton Hydraulics

In the late 1950's the original low speed, high torque hydraulic motor was developed from a pump gerotor element consisting of an internal gear ring and a mating gear or star. While attaching the internal gear ring to the housing as a non moving part, oil was ported to pressurize and turn the internal star in an orbit around a center point. This slow turning star coupled with a splined drive to the output shaft became the Char-Lynn® Orbit® motor. A few years after this original Char-Lynn Orbit motor was introduced another original motor concept went into production. This motor had rolls incorporated into the internal gear ring, this element was identified by the name Geroler® and is a registered trade name of Eaton Hydraulics. From these early years the Geroler motor has seen many design changes

to make these Geroler motors the best the industry has to offer. Examine the simplicity of these Geroler disc valve motors shown below. Also examine all the following pages for high value Char-Lynn disc valve motors from Eaton Hydraulics.

Geroler® Displacement Mechanism

Motors with the Geroler element provide high starting and running torque. The Geroler element minimizes friction and thereby increases efficiency while providing smooth output shaft rotation even at very low speeds. Motor shaft rotation can be instantly reversed by changing direction of input/output flow while generating equal torque in either

direction. The displacements available provide a wide variety of speeds and torques from any Series motor.

Disc Valve

The function of the disc valve is to distribute fluid to the Geroler pockets. The pressure balanced sealing surface on the valve face maintains minimal leakage. Char-Lynn disc valve motors can be used in the same system with a radial piston pump and also in closed loop systems. The patented wear compensated disc valve provides top performance.

Heavy Duty Bearings

Roller bearings permit high radial loads. The radial load capacity is matched to the torque capability of the motor. The high radial load capacity can eliminate the need for outboard bearings or other mechanical components thereby reducing installation cost and allowing the motors to be used on heavier vehicles in traction drive applications.

2000 Series Motor

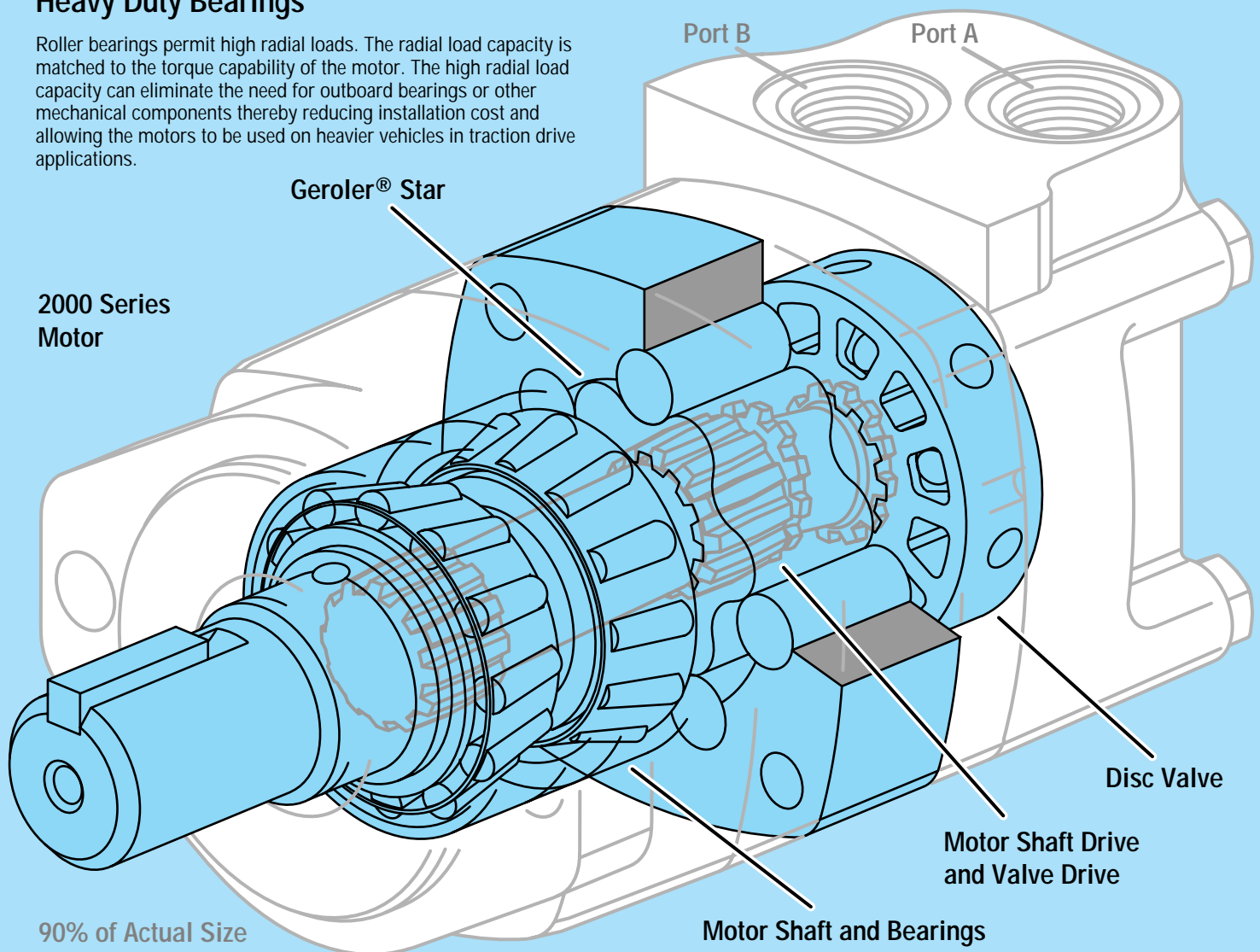

Design Features

Char-Lynn Hydraulic motors provide design flexibility. All disc valve motors are available with various configurations consisting of:

- Displacement (Geroler size)
- Output Shaft
- No Shaft and Bearing Assembly (Bearingless Motor)
- Port Configuration
- Mounting Flange
- Other Special Features

Standard Motor

The standard motor mounting flange is located as close to the output shaft as possible. This type of mounting supports the motor close to the shaft load. This mounting flange is also compatible with many standard gear boxes.

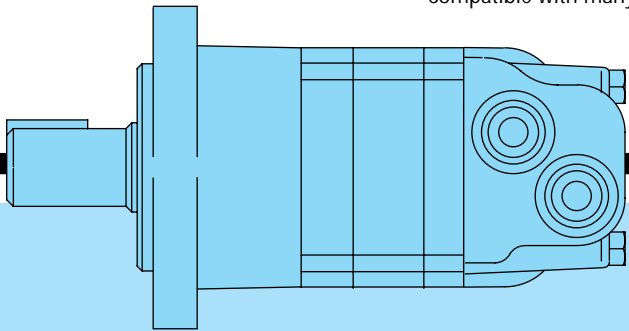

Wheel Motor

The wheel motor mounting flange is located near the center of the motor which permits part or all of the motor to be located inside the wheel or roller hub. In traction drive applications, loads can be positioned over the motor bearings for best bearing life. This wheel motor mounting flange provides design flexibility in many applications.

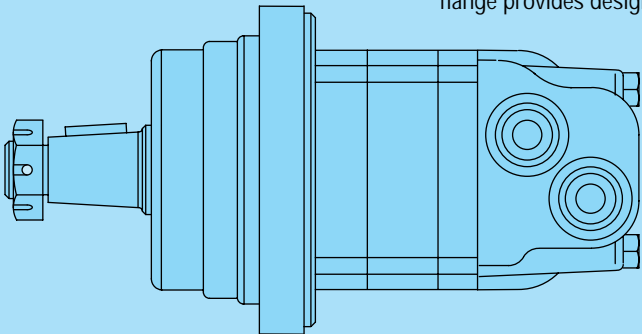

Bearingless Motor

This bearingless motor has the same drive components as the standard and wheel motors (with the exception that the motor is assembled without the output shaft, bearings and bearing housing). The bearingless motor is especially suited for applications such as gear boxes, winch drives, reel and roll drives. Bearingless motor applications must be designed with a bearing supported internal spline to mate with the bearingless motor drive. Product designs using these hydraulic motors provide considerable cost savings.

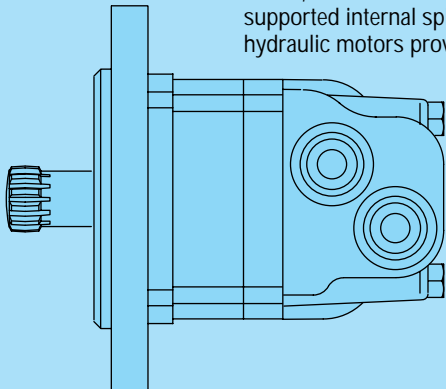

2000 Series

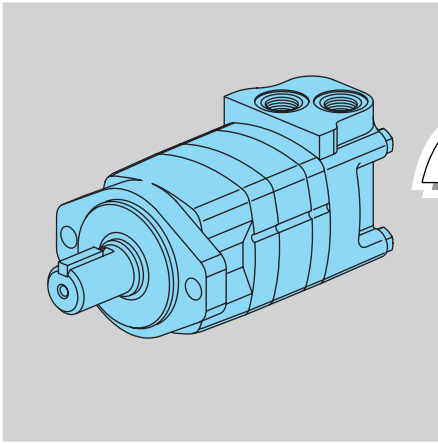

2000

2000 Series

Geroler® Element	9 Displacements
Flow LPM [GPM]	75 [20] Continuous**
	115 [30] Intermittent*
Speed	Up to 924 RPM
Pressure Bar [PSI] ...	200 [3000] Cont.
	300 [4500] Inter.
Torque Nm [lb-in]	845 [7470] Cont.
	930 [8225] Inter.

2000 Series Displacement Size = cubic centimeter per shaft revolution (cm³/r)
= cubic inch per shaft revolution ([in³/r])

- 80 [4.9]
- 100 [6.2]
- 130 [8.0]
- 160 [9.6]
- 195 [11.9]
- 245 [14.9]
- 305 [18.7]
- 395 [24.0]
- 490 [29.8]

Mounting Flange

- 4 Bolt (Bearingless) 101,6 [4.00] Pilot Dia. and 13,59 [.535] Dia. Mounting Holes on 127,0 [5.00] Dia. B.C.
- 2 Bolt (SAE A) (Standard) 82,5 [3.25] Pilot Dia. and 13,59 [.535] Mounting Holes on 106,4 [4.19] Dia. B.C.
- 4 Bolt (Wheel) 107,9 [4.25] Pilot Dia. and 13,59 [.535] Dia. Mounting Holes on 147,6 [5.81] Dia. B.C.
- 4 Bolt (Standard) 82,5 [3.25] Pilot Dia. and 13,59 [.535] Dia. Mounting Holes on 106,4 [4.19] Dia. B.C.
- 4 Bolt Magneto 82,5 [3.25] Pilot Dia. and 13,59 [.535] Dia. Mounting Holes on 106,4 [4.19] Dia. B.C.
- 2 Bolt (SAE B) 101,6 [4.00] Pilot Dia. and 14,27 [.562] Dia. Mounting Holes on 146,0 [5.75] Dia. B.C.

Output Shaft

- Bearingless
- 1 inch Dia. Straight with Woodruff Key, 1/4-20 Threaded Hole and 38,4 [1.51] Max. Coupling Length
- 1-1/4 inch Dia. Straight with Straight Key, 3/8-16 Threaded Hole and 47,3 [1.86] Max. Coupling Length
- 32 mm Dia. Straight with Straight Key, M8 x 1,25 -6H Threaded Hole and 56,4 [2.22] Max. Coupling Length
- 1-1/4 inch Dia. Splined 14 T, 3/8-16 Threaded Hole and 33,0 [1.30] Min. Full Spline Length and 45,5 [1.79] Max. Coupling Length
- 1-1/4 inch Dia. Tapered with Straight Key and Nut
- SAE 6B Splined 6 T, 1/4-20 Threaded Hole and 22,8 [.90] Min. Full Spline Length and 28,8 [1.13] Max. Coupling Length
- 7/8 inch Dia. Splined 13 T, 15,2 [.60] Min. Full Spline Length and 30,8 [1.21] Max. Coupling Length
- 25 mm Dia. Straight with Straight Key, M8 x 1,25 -6H Threaded Hole and 38,1 [1.50] Max. Coupling Length

Port Type

- 7/8-14 O-ring (Staggered) with 7/16-20 O-ring Case Drain
- G 1/2 (BSP) (Staggered) with G 1/4 (BSP) Case Drain
- Manifold Mount with 3/8-16 UNC Mounting Threads (3) and 7/16-20 O-ring Case Drain
- Manifold Mount with M10 x 1,5 -6H Mounting Threads (3) and G 1/4 (BSP) Case Drain
- 1-1/16—12 O-ring (Positioned 180° Apart) with 7/16-20 O-ring Case Drain
- 7/8-14 O-ring (End Ports) with 7/16-20 O-ring Case Drain (Rear)

Special Features

- Viton® Shaft Seal
- Viton Seals
- Free Running Geroler
- Speed Sensor
- Two Speed Option
- Hot Oil Shuttle
- Corrosion Protected
- Seal Guard Package

** Continuous— (Cont.) Continuous rating, motor may be run continuously at these ratings.

* Intermittent— (Inter.) Intermittent operation, 10% of every minute.

Viton® is a Registered Trade Name of Dupont Corp.

4000 Compact Series

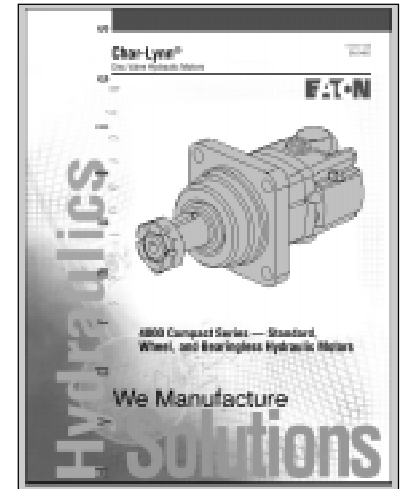

See Catalog 11-01-113 for a Char-Lynn 4000 Compact Series hydraulic motor, this motor has the same package size as the 2000 Series with 4000 Series performance.

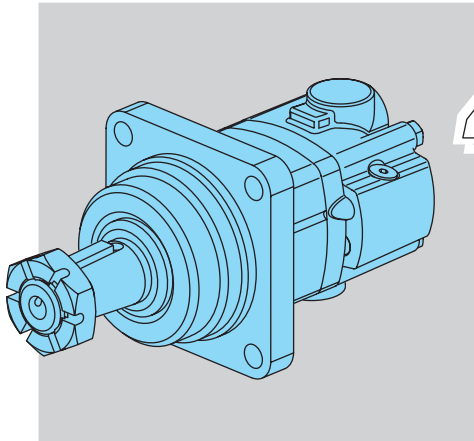

4000 Compact Series

4000 Compact Series

Geroler® Element.....	6 Displacements
Flow LPM [GPM]	75 [20] Continuous**
	115 [30] Intermittent*
Speed	Up to 707 RPM
Pressure Bar [PSI] ...	200 [3000] Cont.
	300 [4500] Inter.
Torque Nm [lb-in]	932 [8250] Cont.
	1166 [10320] Inter.

4000 Compact Series Displacement Size = cubic centimeter per shaft revolution (cm³/r)
= cubic inch per shaft revolution ([in³/r])

- 160 [9.8]
- 200 [12.3]
- 250 [15.4]
- 325 [19.8]
- 395 [24.0]
- 490 [29.8]

Mounting Flange

- 4 Bolt (Bearingless) 101,6 [4.00] Pilot Dia. and 13,59 [.535] Dia. Mounting Holes on 127,0 [5.00] Dia. B.C.
- 2 Bolt (SAE A) (Standard) 82,5 [3.25] Pilot Dia. and 13,59 [.535] Mounting Holes on 106,4 [4.19] Dia. B.C.
- 4 Bolt (Wheel) 107,9 [4.25] Pilot Dia. and 13,59 [.535] Dia. Mounting Holes on 147,6 [5.81] Dia. B.C.
- 4 Bolt (Standard) 82,5 [3.25] Pilot Dia. and 13,59 [.535] Dia. Mounting Holes on 106,4 [4.19] Dia. B.C.
- 4 Bolt Magneto 82,5 [3.25] Pilot Dia. and 13,59 [.535] Dia. Mounting Holes on 106,4 [4.19] Dia. B.C.
- 2 Bolt (SAE B) 101,6 [4.00] Pilot Dia. and 14,27 [.562] Dia. Mounting Holes on 146,0 [5.75] Dia. B.C.

Output Shaft

- Bearingless
- 1-1/4 inch Dia. Straight with Straight Key, 3/8-16 Threaded Hole and 47,3 [1.86] Max. Coupling Length
- 1-1/2 inch Dia. Straight with Straight Key, 3/8-16 Threaded Hole and 67,8 [2.67] Max. Coupling Length
- 32 mm Dia. Straight with Straight Key, M 8 x 1,25 -6H Threaded Hole and 56,4 [2.22] Max. Coupling Length
- 40 mm Dia. Straight with Straight Key, M12 x 1,75 -6H Threaded Hole and 79,6 [3.13] Max. Coupling Length
- 1-1/4 inch Dia. Splined 14 T, 3/8-16 Threaded Hole and 38,1 [1.50] Min. Full Spline Length and 53,1 [2.09] Max. Coupling Length
- 1-1/2 inch Dia. Splined 17 T, 31,2 [1.23] Min. Full Spline Length and 51,8 [2.04] Max. Coupling Length
- 1-1/4 inch Dia. Tapered with Straight Key and Nut
- 1-5/8 inch Dia. Tapered with Straight Key and Nut

Port Type

- 7/8-14 O-ring (Staggered) with 7/16-20 O-ring Case Drain
- G 1/2 (BSP) (Staggered) with G 1/4 (BSP) Case Drain
- Manifold Mount with 3/8-16 UNC Mounting Threads (3)
- Manifold Mount with M10 x 1,5 -6H Mounting Threads (3)
- 1-1/16-12 O-ring (Positioned 180° Apart)
- 7/8-14 O-ring (End Ports) with 7/16-20 O-ring Case Drain (Rear)

Case Flow

- 7/16-20 UNF 2-B O-ring Port
- G 1/4 (BSP) Straight Thread Port
- Hot Oil Shuttle with 7/16-20 UNF 2-B O-ring Port
- Hot Oil Shuttle with G 1/4 (BSP) Straight Thread Port

Back-Pressure Relief Valve

- Set at 4,5 bar [65 PSI]

Special Features

- Viton® Seal
- Speed Sensor
- Corrosion Protected
- Seal Guard Package

Viton® is a Registered Trade Name of Dupont Corp.

** Continuous— (Cont.) Continuous rating, motor may be run continuously at these ratings.

* Intermittent— (Inter.) Intermittent operation, 10% of every minute.

4000 Series

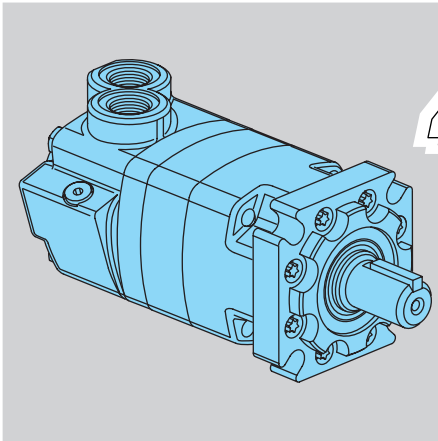

4000

4000 Series

Geroler® Element	10 Displacements
Flow LPM [GPM]	95 [25] Continuous**
	150 [40] Intermittent*
Speed	Up to 868 RPM
Pressure Bar [PSI] ...	200 [3000] Cont.
	300 [4500] Inter.
Torque Nm [lb-in]	970 [8600] Cont.
	1180 [10450] Inter.

4000 Series Displacement Size = cubic centimeter per shaft revolution (cm³/r)
= cubic inch per shaft revolution ([in³/r])

- 110 [6.7]
- 130 [7.9]
- 160 [9.9]
- 205 [12.5]
- 245 [15.0]
- 280 [17.1]***
- 310 [19.0]
- 395 [24.0]
- 495 [30.0]
- 625 [38.0]

Mounting Flange

- 4 Bolt (Bearingless) 127,0 [5.00] Pilot Dia. and 14,27 [.562] Dia. Mounting Holes 161,9 [6.38] Dia. B.C.
- 4 Bolt (SAE B) (Standard) 101,6 [4.00] Pilot Dia. and 14,7 [.58] Mounting Slots on 127,0 [5.00] Dia. B.C.
- 4 Bolt (Wheel) 139,7 [5.50] Pilot Dia. and 14,3 [.56] Dia. Mounting Holes on 165,1 [6.50] Dia. B.C.
- 4 Bolt (SAE C) (Standard) 127,0 [5.00] Pilot Dia. and 14,3 [.56] Dia. Mounting Holes on 161,9 [6.38] Dia. B.C.

Output Shaft

- Bearingless
- 1-1/4 inch Dia. Straight with Straight Key, 3/8-16 Threaded Hole and 53,1 [2.09] Max. Coupling Length
- 1-5/8 inch Dia. Tapered with Straight Key and 1-1/4—18 UNEF Slotted Hex. Nut
- 1-1/4 inch Dia. Splined 14 T with 38,1 [1.50] Min. Full Spline Length and 53,1 [2.09] Max. Coupling Length
- 1-1/2 inch Dia. Splined 17 T with 31,2 [1.23] Min. Full Spline Length
- 40 mm Dia. Straight with Straight Key, M12 x 1,75-6H Threaded Hole

Port Type

- 1-1/16—12 O-ring with 7/16-20 O-ring Case Drain and Check Valve
- G 3/4 (BSP) O-ring with G 1/4 (BSP) O-ring Case Drain and Check Valve
- 3/4 inch 4 Bolt Split Flange with 7/16-20 O-ring Case Drain and Check Valve
- 7/8-14 O-ring with 9/16-18 O-ring Case Drain with Shuttle Valve

Special Features

- Viton Shaft Seal
- Viton Seals
- Hot Oil Shuttle
- Corrosion Protected

*** For performance and dimension data contact your Eaton Hydraulics representative.

** Continuous— (Cont.) Continuous rating, motor may be run continuously at these ratings.

* Intermittent— (Inter.) Intermittent operation, 10% of every minute.

10,000 Series

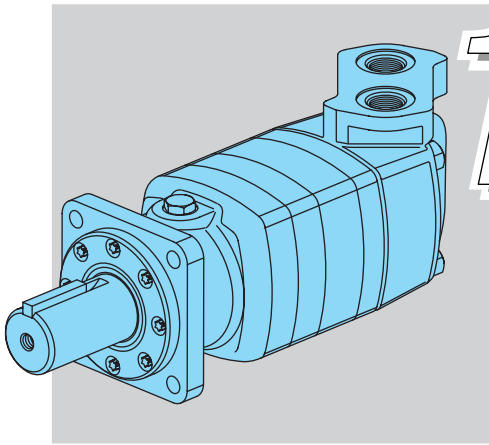

10,000

10,000 Series

Geroler® Element	4 Displacements
Flow LPM [GPM]	170 [45] Continuous**
	265 [70] Intermittent*
Speed	Up to 784 RPM
Pressure Bar [PSI] ...	200 [3000] Cont.
	270 [4000] Inter.
Torque Nm [lb-in] ...	2700 [23910] Cont.
	3440 [30460] Inter.

10,000 Series Displacement Size = cubic centimeter per shaft revolution (cm³/r)
= cubic inch per shaft revolution ([in³/r])

- 345 [21.0]
- 480 [29.2]
- 665 [40.6]
- 940 [57.4]

Mounting Flange

- 4 Bolt (Bearingless) 152,4 [6.00] Pilot Dia. and 20,88 [.522] Dia. Mounting Holes 228,6 [9.00] Dia. B.C.
- 4 Bolt (Standard) 127,0 [5.00] Pilot Dia. and 17,02 [.670] Mounting Holes on 161,9 [6.37] Dia. B.C.
- 4 Bolt (Wheel) 177,8 [7.00] Pilot Dia. and 17,02 [.670] Dia. Mounting Holes on 209,5 [8.25] Dia. B.C.

Output Shaft

- Bearingless
- 2-1/4 inch Dia. Straight with Straight Key, 1/2-20 Threaded Hole and 97,5[3.84] Max. Coupling Length
- 2-1/4 inch Dia. Tapered with Straight Key and 1-1/2—18 UNEF Slotted Hex. Nut
- 2-1/8 inch Dia. Splined 16 T with 52,1 [2.05] Min. Full Spline Length and 1/2-20 UNEF Threaded Hole

Port Type

- 1-5/16-12 O-ring with 9/16-18 O-ring Case Drain
- 1-1/4 Split Flange with 9/16-18 O-ring Case Drain

Special Features

- Viton Shaft Seal
- Viton Seals
- Two Speed Option
- Corrosion Protected

** Continuous— (Cont.) Continuous rating, motor may be run continuously at these ratings.

* Intermittent— (Inter.) Intermittent operation, 10% of every minute.

Design Flexibility

Char-Lynn motors are truly built for high torque low speed. A lot of power is derived from this small package. This power advantage provides the designer with a product that can be used for overall compactness in addition to taking full advantage of the high pressure ratings typical of present day hydraulic components.

Char-Lynn Disc Valve hydraulic motors allow the designer to put the power where it is needed. Indeed, these motors are small in size, big in output power. Hence, the small package can eliminate a lot of installation problems. Furthermore, the motors can be mounted directly on the driven device away from the original power source which eliminates other mechanical linkages such as chains, sprockets, belts, pulleys, gears, rotating drive shafts, and universal joints. Several motors can be driven from the same power source and can be connected in series or parallel to each other.

Durability

The design and method of manufacture of three critical drive train components, valve drive, shaft drive, and output shaft, give these motors durability. Consequently, these durable disc valve motors stand up against high hydraulic pressures. Other built in features, such as the rugged **Tapered** roller bearings provide a good match to this tough design.

Performance Rating

Our method of rating these motors recognizes that at slower speeds and flow, higher pressures and torque are permitted. Hence, our performance data shows the complete flow range (down to 1 liter per minute or 1/4 gallon per minute) and speed range (down to one revolution per minute depending on application).

Controllable Speeds

Char-Lynn motors operate at low speeds that remain very near constant even when load varies. Shaft speed is varied smoothly, easily and economically using simple inexpensive controls. Also, these motors are reversible. Consequently, direction of shaft rotation can be changed instantly with equal output torque in either direction.

Dependable Performance

Highly precise manufacturing of parts and the disc valve's unique wear compensating design provide consistent, dependable performance and long life even under varying conditions.

Reliability

Char-Lynn motors are self contained, with hydraulic fluid providing lubrication. These motors are completely sealed so they can operate safely and reliably in hostile environments such as dust, dirt, steam, water, and heat and provide reliable performance.

High Efficiencies

Char-Lynn disc valve motors have high efficiencies providing high output for the pressure and flow supplied. The high mechanical efficiency enables you to obtain a given torque with a smaller displacement motor.

Volumetric efficiency is high and speed is relatively constant with little variation due to changes in load. Speed is controlled easily and smoothly.

In conclusion, these efficiencies mean less heat buildup in the hydraulic system.

Case Drain and Shuttle Valve Options

Many hydraulic systems can benefit from the use of a system case drain. Char-Lynn disc valve motors provide this feature built in. One of the advantages for case drain flow is that contamination is flushed from the system. This flushing also aids in cooling the system and lowering the case pressure which will extend motor seal life. With a case drain line in place, oil pressure in the gear box (Bearingless motor applications) can also be controlled. In applications where more system cooling and flushing is required, a shuttle valve option is available in 2000, 4000, and 6000 Series motors.

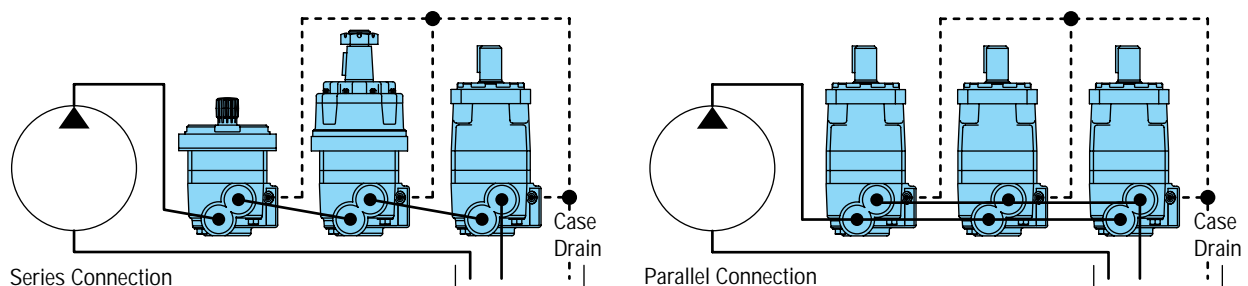

Typical (Closed Loop) Hydraulic Circuit Shuttle Flow 2000, 4000, 6000 Series

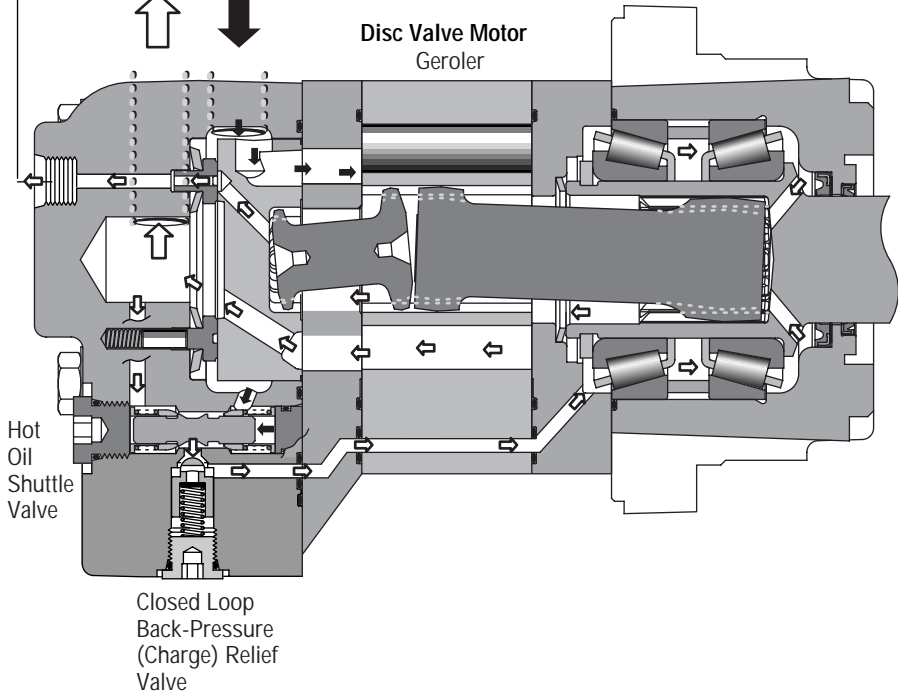
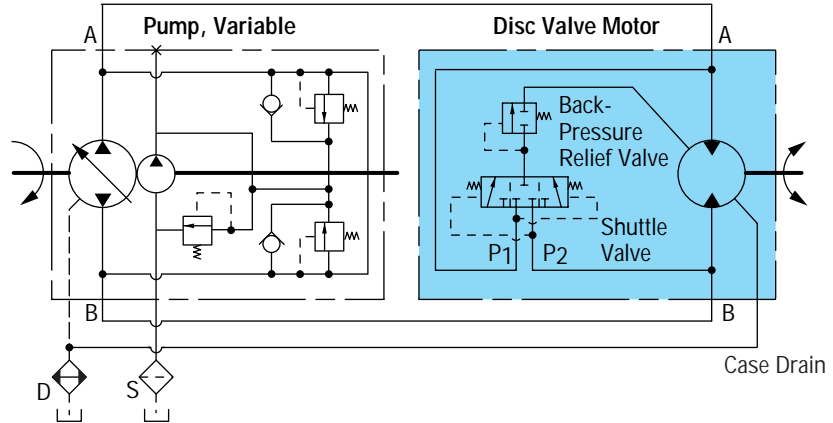
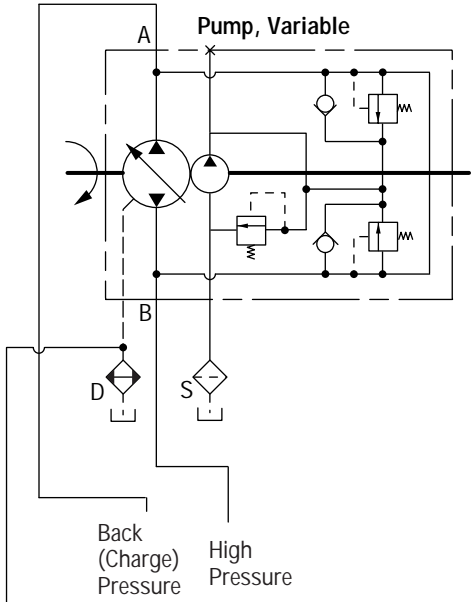
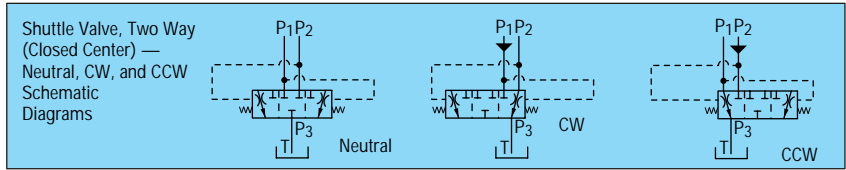

Typical Disc Valve Motor Shuttle Flow with 4,5 bar [65 PSI] Back-Pressure Relief Valve (Typical Data)
Due to Machining Tolerances, Flow May be More or Less

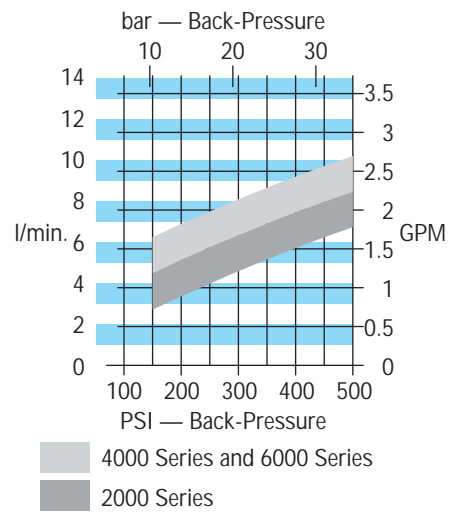

Disc Valve Motor with shuttle valve **must have a case drain to tank**, without this drain line the internal drive splines will not have adequate lubrication.

Low Speed High Torque Hydraulic Motors with Shuttle and Charge Pressure Relief Valve — Patent No. U.S. 4,645,438.

Speed Sensor 2000, 4000 and 6000 Series

Eaton has developed a speed sensor specifically designed for LSHT motors. The design is rugged and fully protected against accidental reverse polarity or short circuit hook up. A built in pull up resistor simplifies installation with control systems.

This sensor is fully compatible with mobile vehicle electrical systems and gives a reliable digital on/off signal over a wide speed range and temperature range. The sensor is field-serviceable; no factory setting or shimming is required.

Supply Voltage: 8 to 24 Vdc (compatible with 12V vehicle systems)

Supply Current: 20 mA max. (Vs) (including internal pull-up resistor)

Output Voltage: Low < .5 Vdc @ 10 mA; output is open collector with 10kΩ pull-up resistor.

Connection — standard 3 prong Weatherpack connector with 18 AWG (american wire gage) cables:

- Position A (red) = power supply
- Position B (white) = signal output
- Position C (black) = common

2000 Series

Output Speed Sensor — digital on/off signal from a Hall Effect switch; 30 pulses/revolution

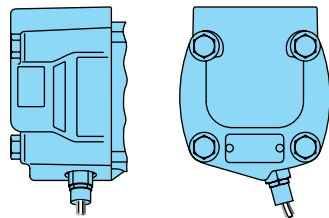

Output Quadrature Speed Sensor — 60 pulses/revolution

4000 Series

Output Speed Sensor — digital on/off signal from a Hall Effect switch; 36 pulses/revolution

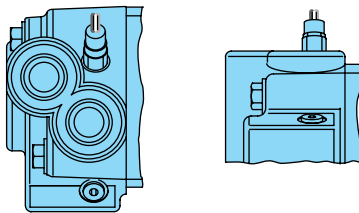

Output Quadrature Speed Sensor — 72 pulses/revolution

6000 Series

Output Speed Sensor — digital on/off signal from a Hall Effect switch; 40 pulses/revolution

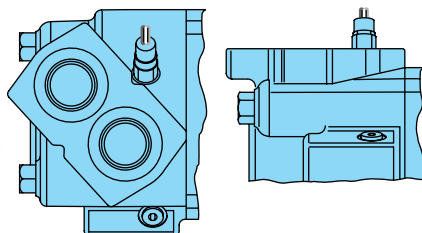

Output Quadrature Speed Sensor — 80 pulses/revolution

Quadrature Speed Sensor 2000, 4000 and 6000 Series

Eaton has developed a new **speed** and **direction** sensor, based on the field proven technology of our standard sensor, designed for off road environments. The new sensor is based on the principle of quadrature and has two output versions.

- The first version has two output signals 90° out of phase. Each output provides one pulse per target tooth.
- The second version has a speed signal that is twice the output pulses per revolution and it also has a direction signal. For example, the 2000 Series versions provide 60 symmetrical pulses per revolution with the 30-tooth target.

Outputs — Digital signals from NPN transistors (open collector output with internal 10K pull-up resistors).

Supply Voltage: 8 to 24 Vdc* (compatible with 12V vehicle conditions)

Supply Current: 40 mA max. (Including internal pull-up resistors)

Output

Low Voltage: 0.5 Vdc maximum @ 10 mA

The sensor has reverse polarity protection, short circuit protection, load dump protection and EMC (Electromagnetic Compatibility) protection (the customer should qualify the EMC protection in their specific application).

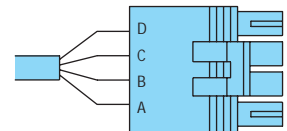

Weatherpack Tower Connector

Connections —

Standard 4 prong Weatherpack connector with 18 AWG (American Wire Gage) cables or M12 threaded connector:

Weatherpack (Version 1)

- Position A (red) = power supply
- Position B (black) = common
- Position C (orange) = output one
- Position D (yellow) = output two

M12 Connector (Version 1)

- Pin 1 = power supply
- Pin 2 = output one
- Pin 3 = common
- Pin 4 = output two

Weatherpack (Version 2)

- Position A (red) = power supply
- Position B (black) = common
- Position C (blue) = speed signal
- Position D (white) = direction

M12 Connector (Version 2)

- Pin 1 = power supply
- Pin 2 = direction
- Pin 3 = common
- Pin 4 = speed signal

Note: The speed sensor or quadrature speed sensor option does **NOT** include read-out display. Possible sources for read-out display include:

Eaton Corporation
Durant Products
 901 South 12th Street
 Watertown, WI 57094
 1-800-289-3866

Shaft Seal

This time proven shaft seal design has a patented feature which allows the seal lip to follow shaft deflection under high side loads and therefore provides better sealing. Additionally, these seals can withstand case pressure up to: 140 Bar [2000 PSI] 2000 Series, 100 Bar [1500 PSI] 4000 Series, 70 Bar [1000 PSI] 6000 Series, and 20 Bar [300 PSI] 10,000 Series.

To optimize seal life, reduce case pressures (with case drain) at shaft speeds greater than 250 RPM.

Optional Seal Guard Package for 2000, 4000, and 6000 Series

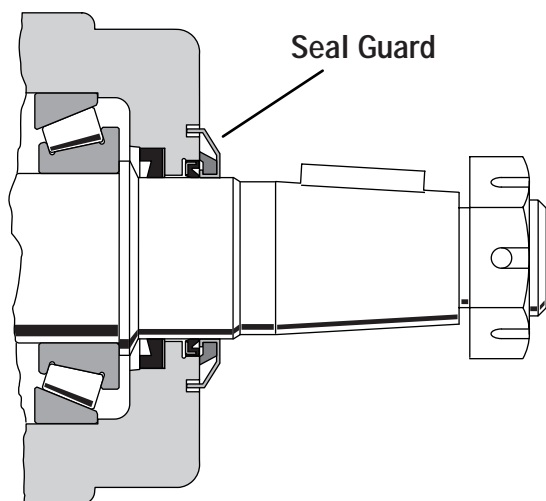

In response to the need for robust seal protection requirements, Eaton now offers a seal guard package. This feature consists of a metal shield that protects an internal wiper seal. The shield is interference-fit on the output shaft and rotates with the output shaft. For added protection, the shield is recessed into a special groove in the bearing housing face.

Centrifugal force causes foreign debris to be forced away from the high pressure shaft and dust seal area. The seal guard does not seal hydraulic fluid. Instead, it protects the standard seals from damage caused by foreign debris. Typical applications benefiting from this feature include street sweepers, industrial sweepers, and harvesting machinery.

NOTE: This option is used in conjunction with the special front retainer with shield groove. Special feature (Hardware) option code "28" for 2000, "13" for 4000, and "14" for 6000 Series, **these motors include the seal guard package, special front retainer and a special shaft with additional length** (6000 Series with design code -006 (effective December 1, 1995) will not require a special front retainer and standard shafts will accept the seal guard).

Internal Check Valves

An internal check valve is provided to relieve case pressure to the low pressure side of the motor. This check valve system is adequate for most applications. In addition, motors have an external case pressure drain port for use when continuous back pressure exceeds: 140 Bar [2000 PSI] 2000 Series, 100 Bar [1500 PSI] 4000 Series, 70 Bar [1000 PSI] 6000 Series, and 20 Bar [300 PSI] 10,000 Series.

Corrosion Protected Disc Valve Motors

2000, 4000, 6000, and 10,000 Series motors are available with a corrosion resistant coating for use in hostile environments. This coating protects the motor from salt water, and various chemicals and is especially effective in marine, food processing, cleansing, fishing, and agricultural applications. Motor output shaft plating helps eliminate seal damage caused by these caustic or acid materials. Char-Lynn disc valve motors are available with just the output shaft plated, or with plated shaft and entire motor exterior coating.

Contents

General Information

Description, Features and Options	Page 2- 3
Product Overview 2000 Series Motors	4
Product Overview 4000 Compact Series Motors	5
Product Overview 4000 Series Motors	6
Product Overview 6000 Series Motors	7
Product Overview 10 000 Series Motors	8
General Hydraulic Motor Information	9
Shuttle Flow Hydraulic Circuit Explanation	10
Speed Sensor and Quadrature Speed Sensor	11
Shaft Seal and Seal Guard Option	12
Internal Check Valves	12
Corrosion Protection	12
Contents	13

Product Information — 2000 Series Motors

Specifications	14
Performance Data	15-19
Dimensions — Standard and Wheel Mount	20-21
Dimensions — Bearingless	22
Installation Information — Bearingless Motor	23
Dimensions — Mounting Flanges	24
Dimensions — Shafts	25
Shaft Side Load — Standard and Wheel	26
Dimensions — Ports	27-28
Product Numbers	29
Model Code	30
Two Speed Motor	31
Two Speed Motor Circuit	32
Two Speed Motor Specifications	33
Two Speed Motor Dimensions	34
Two Speed Motor Product Numbers	35
Hayes Brake System	36

Product Information — 4000 series Motors

Specifications	37
Performance Data	38-41
Dimensions — Standard and Wheel Mount	42-43
Dimensions — Bearingless	44
Installation Information — Bearingless Motor	45
Dimensions — Shafts	46
Shaft Side Load — Standard and Wheel	47
Dimensions — Ports	48
Product Numbers	49
Model Code	50

Product Information — 6000 Series Motors

Specifications	51
Performance Data	52-53
Dimensions — Standard and Wheel Mount	54-55
Dimensions — Global Mount (Similar to ISO 3019/2)	56
Dimensions — Bearingless	57
Installation Information — Bearingless Motor	58
Dimensions — Shafts	59
Shaft Side Load — Standard and Wheel	60
Dimensions — Ports	61
Product Numbers	62
Model Code	63

Product Information — 10 000 Series Motors

Specifications	64
Performance Data	65-66
Dimensions — Standard and Wheel Mount	67-68
Dimensions — Bearingless	69
Installation Information — Bearingless Motor	70
Dimensions — Shafts	71
Shaft Side Load — Standard and Wheel	72
Dimensions — Ports	73
Product Numbers	74
Model Code	75
Two Speed Motor	76
Two Speed Motor Circuit	77
Two Speed Motor Specifications	78
Two Speed Motor Dimensions	79
Two Speed Motor Product Numbers	80

Fluid Recommendations

Char-Lynn Disc Valve Motors	81
-----------------------------------	----

Motor Application Information

Vehicle Drive Calculations	82-83
----------------------------------	-------

Specifications

2000 Series

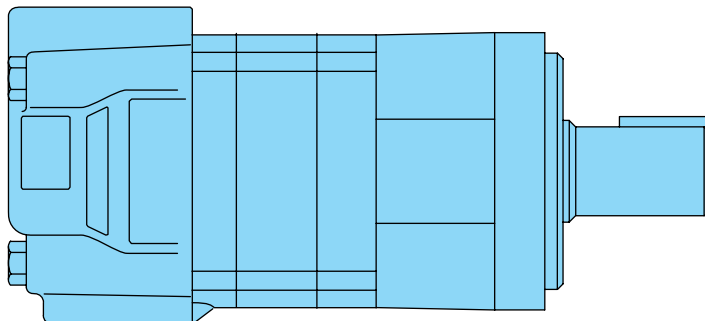

Specification Data—2000 Series

Displ. cm ³ /r [in ³ /r]		80 [4.9]	100 [6.2]	130 [8.0]	160 [9.6]	195 [11.9]	245 [14.9]	305 [18.7]	395 [24.0]	490 [29.8]	
Max. Speed (RPM) @ Flow	Continuous	799	742	576	477	385	308	246	191	153	
	Intermittent	908	924	720	713	577	462	365	287	230	
Flow LPM [GPM]	Continuous	75 [20]	75 [20]	75 [20]	75 [20]	75 [20]	75 [20]	75 [20]	75 [20]	75 [20]	
	Intermittent	75 [20]	95 [25]	95 [25]	115 [30]	115 [30]	115 [30]	115 [30]	115 [30]	115 [30]	
Torque Nm [lb-in]	☆ 1-1/4 Inch or 32 mm Dia. Shaft	Continuous	235 [2065]	295 [2630]	385 [3420]	455 [4040]	540 [4780]	660 [5850]	765 [6750]	775 [6840]	845 [7470]
		Intermittent	345 [3035]	445 [3950]	560 [4970]	570 [5040]	665 [5890]	820 [7250]	885 [7820]	925 [8170]	930 [8225]
Pressure Δ Bar [Δ PSI]	☆ 1-1/4 Inch or 32 mm Dia. Shaft	Continuous	205 [3000]	205 [3000]	205 [3000]	205 [3000]	205 [3000]	205 [3000]	205 [3000]	155 [2250]	120 [1750]
		Intermittent	310 [4500]	310 [4500]	310 [4500]	260 [3750]	260 [3750]	260 [3750]	240 [3500]	190 [2750]	140 [2000]
		Peak	310 [4500]	310 [4500]	310 [4500]	310 [4500]	310 [4500]	310 [4500]	310 [4500]	225 [3250]	170 [2500]

Maximum Case Pressure - without Case Drain * — 140 Bar [2000 PSI]

A simultaneous maximum torque and maximum speed NOT recommended. For permissible continuous and intermittent operating combinations of pressure and flow refer to performance data on pages 15-19.

☆ **Maximum torque for 1 inch shaft** — 395 Nm [3500 lb-in] Continuous and 485 Nm [4300 lb-in] intermittent.

* For back pressure over 140 Bar [2000 PSI] use an external case drain. Install case drain lines so that the motor case remains filled at all times.

Maximum inlet pressure — 310 Bar [4500 PSI]. Do not exceed Δ pressure rating (see chart above).

* **Maximum return pressure** — 310 Bar [4500 PSI]. Do not exceed Δ pressure rating (see chart above).

Δ Bar [Δ PSI] — True pressure difference between inlet port and outlet port.

Continuous Rating — Motor may be run continuously at these ratings.

Intermittent Operation — 10% of every minute.

Peak Operation — 1% of every minute.

Recommended Fluids — Premium quality, anti-wear type hydraulic oil with a viscosity of not less than 70 SUS at operating temperature (see page 81).

Recommended Maximum System Operating Temp. — Is 82° C [180° F]

Recommended Filtration — per ISO Cleanliness Code, level 18/13

To assure best motor life, run motor for approximately one hour at 30% of rated pressure before application to full load. Be sure motor is filled with fluid prior to any load applications.

Performance Data 2000 Series

Motors run with high efficiency in all areas designated with a number for torque and speed, however for best motor life select a motor to run with a torque and speed range shown in the light blue area.

80 cm³/r [4.9 in³/r]
Δ Pressure Bar [PSI]

	[500]	[1000]	[1500]	[2000]	[2500]	[3000]	[3500]	[4000]	[4500]
	35	70	105	140	170	205	240	275	310
[.25]	[210]	[420]							
.95	25 3	45 1							
[.5]	[250]	[500]	[740]						
1.9	30 17	50 8	85 3						
[1]	[330]	[670]	[990]	[1300]	[1550]	[1800]	[1950]	[2110]	
3.8	35 44	75 40	110 37	145 34	175 28	205 22	220 14	240 2	
[2]	[330]	[670]	[995]	[1310]	[1580]	[1840]	[2100]	[2365]	[2630]
7.5	35 90	75 85	110 81	145 78	180 72	210 65	235 57	265 49	295 42
[4]	[325]	[670]	[1005]	[1330]	[1620]	[1920]	[2200]	[2480]	[2765]
15	35 182	75 170	115 170	150 166	185 159	215 152	250 140	280 128	310 117
[6]	[320]	[665]	[1010]	[1340]	[1655]	[1975]	[2270]	[2570]	[2880]
23	35 273	75 267	115 259	150 254	185 246	225 238	255 223	290 207	325 192
[8]	[310]	[660]	[1015]	[1345]	[1685]	[2020]	[2330]	[2640]	[2960]
30	35 365	75 375	115 349	150 341	190 333	230 325	265 306	300 286	335 266
[10]	[300]	[650]	[1010]	[1350]	[1700]	[2050]	[2370]	[2690]	[3010]
38	35 456	75 448	115 439	155 429	190 420	230 411	270 388	305 364	340 341
[12]	[285]	[640]	[1005]	[1350]	[1705]	[2065]	[2390]	[2715]	[3035]
45	30 547	70 537	115 530	155 516	195 507	235 497	270 470	305 442	345 415
[14]	[270]	[625]	[990]	[1340]	[1705]	[2065]	[2395]	[2720]	[3030]
53	30 638	70 629	110 622	150 603	195 593	235 584	270 553	305 521	340 490
[16]	[255]	[610]	[975]	[1330]	[1690]	[2055]	[2385]	[2700]	[2995]
61	30 729	70 720	110 714	150 689	190 679	230 670	270 635	305 599	340 564
[18]	[230]	[590]	[955]	[1310]	[1680]	[2025]	[2355]	[2660]	[2935]
68	25 818	65 810	110 795	150 775	190 765	230 756	265 717	300 677	330 638
[20]	[210]	[570]	[930]	[1290]	[1645]	[1985]	[2305]	[2600]	[2845]
76	25 908	65 901	105 880	145 861	185 851	225 842	260 799	295 755	320 712

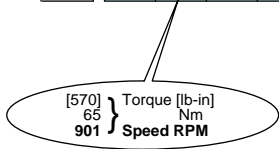

Continuous
Intermittent

100 cm³/r [6.2 in³/r]
Δ Pressure Bar [PSI]

	[250]	[500]	[1000]	[1500]	[2000]	[2500]	[3000]	[3500]	[4000]	[4500]
	15	35	70	105	140	170	205	240	275	310
[.25]	[140]	[260]								
.95	15 4	30 2								
[.5]	[150]	[300]	[620]	[940]						
1.9	15 13	35 9	70 5	105 2						
[1]	[170]	[390]	[830]	[1210]	[1570]	[1870]	[2130]			
3.8	20 35	45 34	95 31	135 28	175 23	210 15	240 6			
[2]	[170]	[390]	[830]	[1220]	[1590]	[1920]	[2220]	[2520]	[2810]	[3120]
7.5	20 73	45 71	95 68	140 63	180 59	215 51	250 38	285 24	315 14	355 4
[4]	[170]	[380]	[820]	[1240]	[1640]	[2010]	[2380]	[2750]	[3120]	[3490]
15	20 148	45 145	90 141	140 136	185 131	225 121	270 104	310 94	355 80	395 69
[6]	[160]	[380]	[820]	[1260]	[1670]	[2080]	[2480]	[2880]	[3280]	[3680]
23	20 222	45 219	90 215	140 209	190 202	235 192	280 172	325 163	370 149	415 134
[8]	[150]	[370]	[810]	[1260]	[1700]	[2130]	[2560]	[2990]	[3420]	[3840]
30	15 297	40 294	90 288	140 281	190 273	240 261	290 243	340 231	385 216	435 200
[10]	[140]	[368]	[810]	[1270]	[1720]	[2160]	[2610]	[3020]	[3440]	[3850]
38	15 371	40 362	90 354	145 344	195 330	245 316	295 300	345 283	390 266	435 226
[12]	[120]	[350]	[800]	[1270]	[1730]	[2180]	[2630]	[3070]	[3510]	[3950]
45	15 445	40 442	90 436	145 427	195 415	245 399	295 389	345 369	395 350	445 332
[14]	[110]	[330]	[800]	[1260]	[1740]	[2180]	[2630]	[3070]	[3500]	[3940]
53	10 519	35 516	90 509	140 500	195 486	245 469	295 463	345 437	395 417	445 378
[16]	[90]	[320]	[780]	[1260]	[1720]	[2160]	[2610]	[3060]	[3500]	[3940]
61	10 594	35 591	90 583	140 573	195 558	245 540	295 537	345 506	395 485	445 463
[18]	[70]	[300]	[770]	[1240]	[1700]	[2140]	[2580]	[3020]	[3460]	[3900]
68	10 668	35 665	85 657	140 646	190 630	240 611	290 609	340 574	390 552	440 529
[20]	[60]	[280]	[730]	[1180]	[1630]	[2090]	[2550]	[2980]	[3440]	[3830]
76	5 742	30 739	80 731	135 715	185 703	235 684	290 662	335 643	390 619	435 595
[22]	[40]	[260]	[720]	[1180]	[1620]	[2070]	[2500]	[2930]	[3360]	
83	5 816	30 813	80 805	135 794	185 777	235 758	280 749	330 712	380 687	
[24]	[20]	[230]	[690]	[1140]	[1540]	[2020]	[2460]	[2900]	[3340]	
91	1.0 890	230 887	80 879	130 868	175 852	230 834	280 814	330 782	375 754	
[25]		[220]	[670]	[1120]	[1560]	[1990]	[2450]	[2890]		
95		25 924	75 916	125 905	175 890	225 873	275 846	325 817		

Performance data is typical at 120 SUS. Actual data may vary slightly from unit to unit in production

Performance Data 2000 Series

Motors run with high efficiency in all areas designated with a number for torque and speed, however for best motor life select a motor to run with a torque and speed range shown in the light blue area.

130 cm³/r [8.0 in³/r]
Δ Pressure Bar [PSI]

160 cm³/r [9.6 in³/r]
Δ Pressure Bar [PSI]

	[250] 15	[500] 35	[1000] 70	[1500] 105	[2000] 140	[2500] 170	[3000] 205	[3500] 240	[4000] 275	[4500] 310
[.25] 1.95	[170] 20 3									
[.5] 1.9	[190] 20 12	[410] 45 8	[870] 100 2							
[1] 3.8	[230] 25 28	[510] 60 27	[1070] 120 23	[1580] 180 19	[2050] 230 16	[2520] 285 13	[2920] 330 9	[3310] 375 3		
[2] 7.5	[230] 25 56	[510] 60 56	[1080] 120 53	[1600] 180 47	[2090] 235 42	[2580] 290 39	[2930] 330 36	[3320] 375 28	[3640] 410 21	[3990] 450 13
[4] 15	[220] 25 114	[500] 55 113	[1080] 120 111	[1620] 185 104	[2150] 245 97	[2660] 300 95	[3100] 350 92	[3540] 400 85	[3980] 450 77	[4420] 500 70
[6] 23	[220] 25 172	[490] 55 171	[1080] 120 169	[1640] 185 161	[2190] 245 153	[2740] 310 149	[3260] 370 146	[3770] 425 132	[4280] 485 118	[4800] 540 104
[8] 30	[200] 25 230	[480] 55 224	[1080] 120 222	[1650] 185 219	[2220] 250 210	[2780] 315 204	[3310] 375 201	[3840] 435 192	[4360] 495 184	[4890] 550 175
[10] 38	[180] 20 287	[470] 55 286	[1070] 120 282	[1650] 185 276	[2230] 250 269	[2800] 315 261	[3420] 385 255	[3940] 445 243	[4450] 505 231	[4970] 560 219
[12] 45	[160] 20 345	[460] 50 344	[1060] 120 338	[1640] 185 333	[2230] 250 327	[2800] 315 317	[3350] 380 307	[3910] 440 295	[4440] 500 284	[4960] 560 272
[14] 53	[150] 15 403	[440] 50 402	[1030] 115 395	[1620] 185 391	[2220] 250 385	[3000] 340 373	[3350] 380 360	[3910] 440 348	[4440] 500 336	
[16] 61	[130] 15 461	[420] 45 460	[1010] 115 452	[1600] 180 447	[2200] 245 443	[2780] 315 430	[3330] 375 411	[3890] 440 397	[4440] 500 384	
[18] 68	[110] 10 518	[400] 45 517	[990] 110 509	[1580] 180 504	[2160] 245 500	[2750] 310 484	[3300] 375 471	[3860] 435 456	[4410] 500 440	
[20] 76	[90] 10 576	[380] 45 575	[960] 110 568	[1550] 175 560	[2130] 240 551	[2710] 305 539	[3280] 370 524	[3840] 435 508		
[22] 83	[60] 5 634	[350] 40 633	[940] 105 624	[1520] 170 619	[2100] 235 604	[2680] 305 597	[3250] 365 579	[3820] 430 560		
[24] 91	[40] 5 692	[325] 35 691	[920] 105 682	[1490] 170 676	[2070] 235 665	[2650] 300 651	[3220] 365 633	[3780] 425 616		
[25] 95	[20] 1.0 720	[310] 35 719	[900] 100 712	[1480] 165 705	[2050] 230 692	[2630] 295 679	[3200] 360 682	[3700] 420 656		

	[250] 15	[500] 35	[1000] 70	[1500] 105	[2000] 140	[2500] 170	[3000] 205	[3500] 240	[3750] 260
[.25] 1.95	[200] 25 3								
[.5] 1.9	[240] 25 9	[490] 55 7	[990] 110 5	[1570] 175 3	[2140] 240 1				
[1] 3.8	[280] 30 23	[590] 65 21	[1170] 130 19	[1730] 195 17	[2290] 260 13	[2830] 320 8	[3330] 375 3	[3820] 430 2	[4070] 460 1
[2] 7.5	[300] 35 46	[610] 70 45	[1210] 135 42	[1790] 200 39	[2350] 265 35	[2920] 330 34	[3480] 395 33	[4050] 460 28	[4330] 490 22
[4] 15	[320] 35 93	[630] 70 92	[1260] 140 89	[1890] 215 85	[2530] 285 79	[3170] 360 77	[3820] 430 75	[4460] 505 59	[4780] 540 43
[6] 23	[320] 35 142	[650] 75 140	[1300] 145 137	[1960] 220 131	[2620] 295 124	[3280] 370 118	[3940] 445 113	[4600] 520 104	[4930] 560 96
[8] 30	[310] 35 190	[650] 75 187	[1330] 150 184	[2010] 225 178	[2670] 300 170	[3330] 375 166	[4000] 450 164	[4660] 525 153	[4990] 565 142
[10] 38	[290] 35 237	[640] 70 235	[1340] 150 231	[2030] 230 226	[2850] 320 212	[3410] 385 212	[4030] 455 205	[4700] 530 193	[5030] 570 187
[12] 45	[270] 30 286	[620] 70 283	[1320] 150 279	[2030] 230 274	[2700] 305 265	[3370] 380 254	[4040] 445 246	[4710] 530 235	[5040] 570 224
[14] 53	[240] 25 334	[590] 65 331	[1300] 145 326	[2020] 230 322	[2690] 305 312	[3360] 375 305	[4030] 455 297	[4700] 530 286	
[16] 61	[220] 25 382	[570] 65 378	[1270] 145 374	[1980] 225 369	[2850] 300 360	[3330] 375 349	[4030] 455 339	[4680] 530 326	
[18] 68	[190] 20 429	[540] 60 426	[1240] 140 422	[1960] 220 416	[2640] 300 407	[3320] 375 394	[3990] 445 387		
[20] 76	[170] 20 477	[510] 60 474	[1210] 135 469	[1920] 215 462	[2630] 300 451	[3310] 375 440	[3940] 445 430		
[22] 83	[150] 15 525	[480] 55 522	[1170] 130 517	[1880] 210 510	[2600] 295 501	[3290] 370 484	[3920] 445 473		
[24] 91	[120] 15 572	[450] 50 569	[1150] 130 564	[1860] 210 556	[2570] 290 546	[3260] 370 531	[3900] 440 522		
[25] 95	[90] 10 596	[440] 50 593	[1140] 130 587	[1840] 210 580	[2560] 290 566	[3230] 365 553	[3880] 440 544		
[30] 114		[330] 35 713	[1040] 120 706	[1750] 200 696	[2470] 280 682	[3140] 355 672	[3800] 430 658		

[330]
35
713 } Torque [lb-in]
Nm
Speed RPM

Continuous
Intermittent

Performance data is typical at 120 SUS. Actual data may vary slightly from unit to unit in production

195 cm³/r [11.9 in³/r]
 Δ Pressure Bar [PSI]

	[250] 15	[500] 35	[750] 50	[1000] 70	[1250] 85	[1500] 105	[1750] 120	[2000] 140	[2250] 155	[2500] 170	[2750] 190	[3000] 205	[3250] 225	[3500] 240	[3750] 260
[.25] .95	[240] 25 4	[590] 65 2													
[.5] 1.9	[290] 35 8	[640] 70 6	[990] 110 5	[1340] 150 2											
[1] 3.8	[380] 45 17	[730] 80 16	[1100] 125 15	[1430] 160 13	[1790] 200 20	[2120] 210 11	[2450] 275 9	[2720] 305 7	[2990] 340 5	[3260] 370 4	[3540] 400 3	[3810] 430 2	[4080] 460 2	[4350] 490 1	[4620] 520 1
[2] 7.5	[390] 45 37	[755] 85 35	[1135] 130 33	[1470] 165 33	[1860] 210 32	[2195] 250 31	[2535] 285 28	[2880] 325 26	[3120] 355 24	[3680] 415 21	[4090] 460 20	[4500] 510 19	[4800] 540 17	[5100] 575 14	[5400] 610 14
[4] 15	[405] 45 76	[795] 90 74	[1185] 135 73	[1540] 175 72	[1970] 225 71	[2310] 260 70	[2675] 300 66	[3040] 345 64	[3420] 385 62	[3790] 430 61	[4160] 470 59	[4520] 510 57	[4890] 550 55	[5260] 595 51	[5630] 635 45
[6] 23	[405] 45 115	[815] 90 113	[1220] 140 111	[1590] 180 110	[2035] 230 109	[2395] 270 108	[2780] 315 104	[3170] 360 102	[3560] 400 100	[3940] 445 99	[4320] 490 96	[4700] 530 94	[5070] 570 91	[5450] 615 87	[5830] 660 81
[8] 30	[400] 45 154	[820] 90 151	[1230] 140 149	[1625] 185 148	[2065] 235 147	[2450] 275 146	[2850] 320 143	[3260] 370 140	[3670] 415 137	[4040] 455 135	[4410] 500 132	[4780] 540 130	[5150] 580 127	[5520] 625 123	[5890] 665 117
[10] 38	[380] 45 193	[810] 90 190	[1230] 140 188	[1645] 185 187	[2095] 235 186	[2480] 280 184	[2895] 325 181	[3310] 375 177	[3730] 420 175	[4100] 465 173	[4470] 505 170	[4840] 545 168	[5210] 590 164	[5590] 630 160	
[12] 45	[355] 40 231	[790] 90 229	[1215] 135 227	[1650] 185 226	[2100] 235 224	[2485] 280 221	[2915] 330 219	[3340] 375 218	[3760] 425 215	[4120] 465 211	[4480] 505 208	[4850] 550 204			
[14] 53	[320] 35 269	[765] 85 267	[1190] 135 267	[1645] 185 264	[2090] 235 261	[2475] 280 260	[2915] 330 257	[3350] 380 254	[3770] 425 250	[4130] 465 248	[4480] 505 245	[4860] 550 241			
[16] 61	[290] 30 308	[730] 80 306	[1160] 130 305	[1625] 185 303	[2070] 235 299	[2455] 280 296	[2900] 330 294	[3340] 375 290	[3760] 425 286	[4130] 465 283	[4490] 505 279	[4860] 550 276			
[18] 68	[290] 30 346	[690] 80 345	[1120] 125 345	[1590] 180 342	[2035] 230 337	[2420] 270 334	[2870] 325 327	[3310] 375 321	[3730] 420 315	[4100] 465 315	[4480] 505 308				
[20] 76	[210] 25 385	[650] 75 384	[1080] 120 383	[1550] 175 380	[1995] 225 375	[2380] 270 372	[2830] 320 371	[3270] 370 367	[3690] 415 363	[4070] 460 359	[4450] 500 355				
[22] 83	[170] 20 424	[610] 70 423	[1040] 120 422	[1500] 170 418	[1955] 220 414	[2340] 265 410	[2785] 315 408	[3220] 365 404	[3640] 410 399	[4050] 460 395					
[24] 91	[135] 15 462	[570] 65 461	[1000] 115 460	[1440] 165 457	[1910] 215 453	[2300] 260 449	[2740] 310 446	[3170] 360 441	[3590] 405 436	[3980] 450 432					
[25] 95	[120] 15 484	[550] 60 482	[980] 110 479	[1410] 160 476	[1890] 215 473	[2280] 260 469	[2720] 305 464	[3150] 355 459	[3570] 405 454	[3960] 445 449					
[30] 114		[420] 45 577	[860] 95 575	[1290] 145 571	[1700] 240 567	[2120] 285 562	[2530] 330 556	[2940] 385 550	[3400] 450 542						

Performance Data 2000 Series

Motors run with high efficiency in all areas designated with a number for torque and speed, however for best motor life select a motor to run with a torque and speed range shown in the light blue area.

245 cm³/r [14.9 in³/r]
 Δ Pressure Bar [PSI]

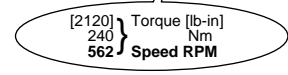

Continuous
 Intermittent

	[250] 15	[500] 35	[750] 50	[1000] 70	[1250] 85	[1500] 105	[1750] 120	[2000] 140	[2250] 155	[2500] 170	[2750] 190	[3000] 205	[3250] 225	[3500] 240	[3750] 260
[.5] 1.9	[410] 45 4	[850] 95 2													
[1] 3.8	[450] 50 14	[930] 105 13	[1420] 160 12	[1850] 210 11	[2320] 260 10	[2780] 315 9	[3250] 365 8	[3650] 410 6	[4100] 465 5	[4540] 515 4	[4980] 560 4	[5430] 615 3	[5870] 665 2	[6310] 715 1	
[2] 7.5	[460] 50 29	[960] 110 28	[1460] 165 27	[1910] 215 26	[2400] 270 25	[2860] 325 23	[3340] 375 22	[3780] 425 20	[4320] 490 19	[4770] 540 18	[5210] 590 17	[5660] 640 15	[6110] 690 14	[6570] 740 12	[6950] 785 10
[4] 15	[470] 55 60	[1000] 115 59	[1540] 175 58	[1980] 225 56	[2510] 285 54	[3010] 340 53	[3480] 395 51	[3980] 450 49	[4450] 505 48	[4910] 555 47	[5380] 610 46	[5850] 675 44	[6320] 715 42	[6780] 765 40	[7250] 820 22
[6] 23	[460] 50 91	[1020] 115 90	[1550] 175 89	[2040] 230 87	[2580] 290 84	[3110] 350 83	[3590] 405 81	[4120] 465 78	[4580] 515 76	[5050] 570 73	[5520] 625 71	[5980] 675 69	[6440] 730 67	[6910] 780 65	
[8] 30	[460] 50 122	[1010] 115 121	[1560] 175 120	[2080] 235 118	[2630] 295 115	[3170] 360 111	[3670] 415 113	[4210] 475 110	[4680] 530 106	[5160] 585 104	[5630] 635 102	[6110] 690 101	[6590] 745 99		
[10] 38	[440] 50 153	[1000] 115 152	[1550] 175 150	[2110] 240 148	[2650] 300 146	[3200] 360 144	[3730] 420 142	[4250] 480 139	[4730] 535 137	[5210] 590 135	[5700] 645 133	[6200] 705 130			
[12] 45	[410] 45 184	[960] 110 183	[1530] 175 182	[2100] 235 180	[2640] 300 177	[3190] 360 175	[3760] 425 173	[4260] 480 170	[4740] 535 168	[5220] 600 165	[5730] 645 162				
[14] 53	[380] 40 215	[910] 105 214	[1500] 170 213	[2080] 235 211	[2600] 295 209	[3160] 355 207	[3760] 425 204	[4230] 480 201	[4710] 530 198	[5190] 585 195					
[16] 61	[340] 40 246	[860] 95 245	[1460] 165 244	[2040] 230 242	[2570] 290 240	[3120] 355 238	[3740] 425 235	[4180] 470 232	[4660] 525 227	[5140] 580 223					
[18] 68	[290] 30 277	[810] 90 276	[1420] 160 275	[2000] 225 273	[2520] 285 271	[3060] 345 269	[3700] 420 266	[4130] 465 263	[4610] 520 258	[5090] 575 253					
[20] 76	[250] 30 308	[800] 90 306	[1350] 155 304	[1910] 215 302	[2460] 280 300	[3010] 340 298	[3630] 410 295	[4110] 465 291	[4610] 520 288						
[22] 83	[200] 25 339	[710] 80 337	[1300] 145 337	[1870] 210 334	[2390] 270 332	[2940] 330 330	[3560] 400 327	[4010] 455 323	[4510] 510 318						
[24] 91	[150] 15 370	[670] 75 369	[1240] 140 367	[1790] 200 364	[2330] 265 362	[2880] 325 360	[3460] 390 357	[3960] 445 353	[4460] 505 344						
[25] 95	[120] 15 385	[660] 75 384	[1210] 135 382	[1750] 200 379	[2300] 260 377	[2860] 325 375	[3410] 385 372	[3950] 445 367	[4470] 505 363						
[30] 114		[520] 60 462	[1080] 120 460	[1620] 185 458	[2180] 245 456	[2720] 305 453	[3260] 370 450	[3790] 430 447							

Performance data is typical at 120 SUS. Actual data may vary slightly from unit to unit in production

Performance Data 2000 Series

305 cm³/r [18.7 in³/r]
 Δ Pressure Bar [PSI]

	[250] 15	[500] 35	[750] 50	[1000] 70	[1250] 85	[1500] 105	[1750] 120	[2000] 140	[2250] 155	[2500] 170	[2750] 190	[3000] 205	[3250] 225	[3500] 240
[.5] 1.9	[500] 55 4	[1050] 120 2												
[1] 3.8	[610] 70 12	[1180] 135 11	[1750] 200 11	[2330] 260 10	[2870] 325 10	[3440] 390 9	[3930] 445 8	[4410] 500 6	[4900] 555 3	[5380] 610 1				
[2] 7.5	[620] 70 24	[1210] 135 24	[1800] 205 23	[2400] 270 22	[2970] 335 22	[3510] 395 20	[4050] 460 19	[4600] 520 18	[5140] 580 17	[5680] 640 15	[6220] 705 13	[6750] 765 11	[7290] 825 8	[7820] 885 6
[4] 15	[680] 75 49	[1250] 140 49	[1880] 210 48	[2500] 280 47	[3120] 355 47	[3690] 415 45	[4260] 480 43	[4840] 545 42	[5410] 610 40	[5980] 675 38	[6550] 740 36	[7120] 805 34	[7690] 870 33	
[6] 23	[620] 70 74	[1270] 145 74	[1920] 215 72	[2560] 290 71	[3230] 365 69	[3810] 430 66	[4390] 495 64	[4970] 560 61	[5560] 630 58	[6130] 695 55	[6710] 760 52	[7290] 825 52		
[8] 30	[600] 70 98	[1270] 145 98	[1940] 220 97	[2600] 295 96	[3290] 370 95	[3880] 440 93	[4470] 505 90	[5070] 575 86	[5660] 640 83	[6250] 705 80	[6840] 775 77			
[10] 38	[570] 65 123	[1250] 140 122	[1940] 220 121	[2610] 295 120	[3310] 375 119	[3920] 440 117	[4530] 510 113	[5150] 580 110	[5760] 650 106	[6370] 720 102				
[12] 45	[530] 60 148	[1220] 140 147	[1920] 215 145	[2600] 295 144	[3300] 375 143	[3920] 440 142	[4530] 510 138	[5150] 580 133	[5760] 650 128	[6370] 720 124				
[14] 53	[480] 55 172	[1180] 135 172	[1870] 210 170	[2560] 290 168	[3260] 370 167	[3900] 440 165	[4510] 510 160	[5120] 580 156	[5730] 645 152					
[16] 61	[430] 50 196	[1120] 125 196	[1820] 205 194	[2500] 280 192	[3210] 365 191	[3870] 440 188	[4480] 505 183	[5080] 575 178	[5690] 645 174					
[18] 68	[370] 40 221	[1060] 120 221	[1760] 200 218	[2440] 275 217	[3140] 355 215	[3800] 440 212	[4420] 500 207	[5050] 570 202						
[20] 76	[320] 35 246	[980] 110 245	[1680] 190 243	[2360] 265 241	[3050] 345 239	[3710] 420 236	[4370] 495 231	[5020] 565 226						
[22] 83	[240] 25 105	[920] 105 270	[1620] 185 268	[2300] 260 266	[2990] 340 263	[3560] 400 260	[4190] 475 258	[4820] 545 255						
[24] 91	[180] 20 296	[870] 100 294	[1550] 175 293	[2240] 255 290	[2920] 330 288	[3420] 385 285	[4020] 455 283	[4630] 525 280						
[25] 95	[150] 15 308	[840] 95 307	[1520] 170 305	[2200] 250 303	[2890] 325 300	[3340] 375 298	[3930] 445 295	[4520] 510 293						
[30] 114	[680] 75 365	[1360] 155 362	[2040] 230 360	[2720] 305 357	[3140] 355 356	[3810] 430 352								

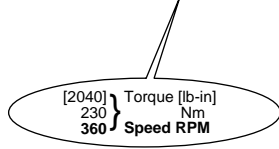

Continuous
 Intermittent

Motors run with high efficiency in all areas designated with a number for torque and speed, however for best motor life select a motor to run with a torque and speed range shown in the light blue area.

395 cm³/r [24.0 in³/r]
 Δ Pressure Bar [PSI]

	[250] 15	[500] 35	[750] 50	[1000] 70	[1250] 85	[1500] 105	[1750] 120	[2000] 140	[2250] 155	[2500] 170	[2750] 190
[.5] 1.9	[560] 65 4	[1310] 150 3									
[1] 3.8	[770] 85 9	[1540] 175 9	[2290] 260 9	[3080] 350 8	[3780] 430 8	[4480] 505 7	[5170] 585 7	[5880] 665 6	[6580] 745 5	[7270] 820 4	[7980] 900 3
[2] 7.5	[790] 90 18	[1580] 180 18	[2360] 265 18	[3180] 360 17	[3930] 445 17	[4680] 530 16	[5430] 615 15	[6180] 700 14	[6840] 775 13	[7500] 845 11	[8170] 925 10
[4] 15	[810] 90 37	[1660] 190 37	[2480] 280 37	[3320] 375 36	[4130] 465 36	[4940] 560 35	[5740] 650 34	[6550] 740 33	[7230] 815 31	[7880] 890 28	
[6] 23	[820] 90 57	[1700] 190 56	[2550] 290 56	[3420] 385 55	[4250] 480 54	[5080] 575 52	[5920] 670 50	[6750] 765 49	[7420] 840 47	[8000] 905 45	
[8] 30	[820] 90 76	[1700] 190 75	[2580] 290 75	[3460] 390 74	[4300] 485 73	[5130] 580 71	[5960] 675 69	[6800] 770 68			
[10] 38	[800] 90 95	[1700] 190 94	[2590] 295 94	[3480] 395 93	[4320] 490 92	[5160] 585 90	[6000] 680 88	[6840] 775 86			
[12] 45	[770] 85 114	[1680] 190 113	[2570] 290 113	[3470] 390 112	[4310] 485 111	[5150] 580 109	[5990] 675 106	[6830] 770 103			
[14] 53	[740] 85 133	[1640] 185 132	[2530] 285 132	[3430] 390 131	[4280] 485 129	[5120] 580 127	[5960] 675 124				
[16] 61	[690] 80 153	[1590] 180 152	[2480] 280 152	[3370] 380 150	[4220] 475 149	[5060] 570 146	[5910] 670 144				
[18] 68	[640] 70 172	[1530] 170 171	[2420] 275 171	[3310] 375 170	[4160] 470 169	[5010] 565 167	[5870] 665 164				
[20] 76	[580] 65 191	[1470] 165 190	[2370] 270 190	[3260] 370 189	[4110] 465 188	[4960] 560 186	[5820] 660 184				
[22] 83	[510] 60 210	[1390] 155 209	[2290] 260 209	[3170] 360 208	[4030] 455 207	[4880] 550 206					
[24] 91	[440] 50 230	[1330] 150 229	[2220] 250 228	[3100] 350 227	[3950] 445 225	[4800] 540 224					
[26] 98	[350] 40 249	[1240] 140 248	[2130] 240 247	[3020] 340 246	[3880] 440 244	[4730] 535 242					
[28] 106	[270] 30 268	[1150] 130 267	[2050] 230 265	[2930] 330 264	[3790] 430 261	[4650] 525 259					
[30] 114	[180] 20 287	[1060] 120 286	[1960] 220 284	[2850] 320 283	[3710] 420 281	[4570] 515 277					

Performance data is typical at 120 SUS. Actual data may vary slightly from unit to unit in production

Performance Data 2000 Series

490 cm³/r [29.8 in³/r]
Δ Pressure Bar [PSI]

	[250] 15	[500] 35	[750] 50	[1000] 70	[1250] 85	[1500] 105	[1750] 120	[2000] 140
[.5] 1.9	[670] 75 2	[1600] 180 1						
[1] 3.8	[920] 105 7	[2000] 225 6	[2990] 340 5	[3900] 440 4	[4880] 550 2			
[2] 7.5	[950] 105 14	[2060] 235 13	[3110] 350 12	[4080] 460 10	[5110] 575 9	[6320] 715 7		
[4] 15	[980] 110 30	[2130] 240 29	[3230] 365 28	[4270] 480 27	[5350] 605 26	[6370] 720 24	[7380] 835 22	[7980] 900 20
[6] 23	[980] 110 45	[2120] 240 44	[3230] 365 43	[4300] 485 42	[5370] 605 41	[6420] 725 39	[7470] 845 37	[8225] 930 35
[8] 30	[980] 110 61	[2110] 240 60	[3220] 365 59	[4330] 490 58	[5400] 610 57	[6470] 730 55	[7550] 855 52	
[10] 38	[920] 105 76	[2050] 230 75	[3170] 360 74	[4300] 485 73	[5390] 610 72	[6460] 730 70	[7550] 855 68	
[12] 45	[860] 95 91	[1990] 225 90	[3120] 355 90	[4260] 480 89	[5370] 605 87	[6460] 730 85	[7560] 855 84	
[14] 53	[790] 90 106	[1930] 220 105	[3055] 345 105	[4185] 475 104	[5300] 600 102	[6400] 725 100		
[16] 61	[720] 80 122	[1870] 210 121	[2990] 340 120	[4110] 465 119	[5230] 590 118	[6340] 715 116		
[18] 68	[630] 70 137	[1770] 200 136	[2890] 325 135	[4020] 455 134	[5140] 580 133	[6260] 705 131		
[20] 76	[550] 60 153	[1670] 190 152	[2800] 315 151	[3940] 445 150	[5060] 570 149	[6180] 700 146		
[22] 83	[450] 50 168	[1570] 175 168	[2700] 305 167	[3830] 435 165	[4960] 560 164	[6070] 685 161		
[24] 91	[360] 40 184	[1480] 165 184	[2600] 295 183	[3730] 420 181	[4860] 550 179	[5970] 675 177		
[26] 98	[270] 30 199	[1390] 155 195	[2510] 285 194	[3640] 410 192	[4770] 540 190			
[28] 106		[1260] 140 212	[2370] 270 211	[3520] 400 209	[4630] 525 207			
[30] 114		[1130] 125 230	[2240] 255 229	[3400] 385 277	[4500] 510 224			

Motors run with high efficiency in all areas designated with a number for torque and speed, however for best motor life select a motor to run with a torque and speed range shown in the light blue area.

[1130]
125
230

 } Torque [lb-in]
 Nm
 Speed RPM

Continuous
 Intermittent

Performance data is typical at 120 SUS. Actual data may vary slightly from unit to unit in production

Dimensions — 2000 Series Standard Motor

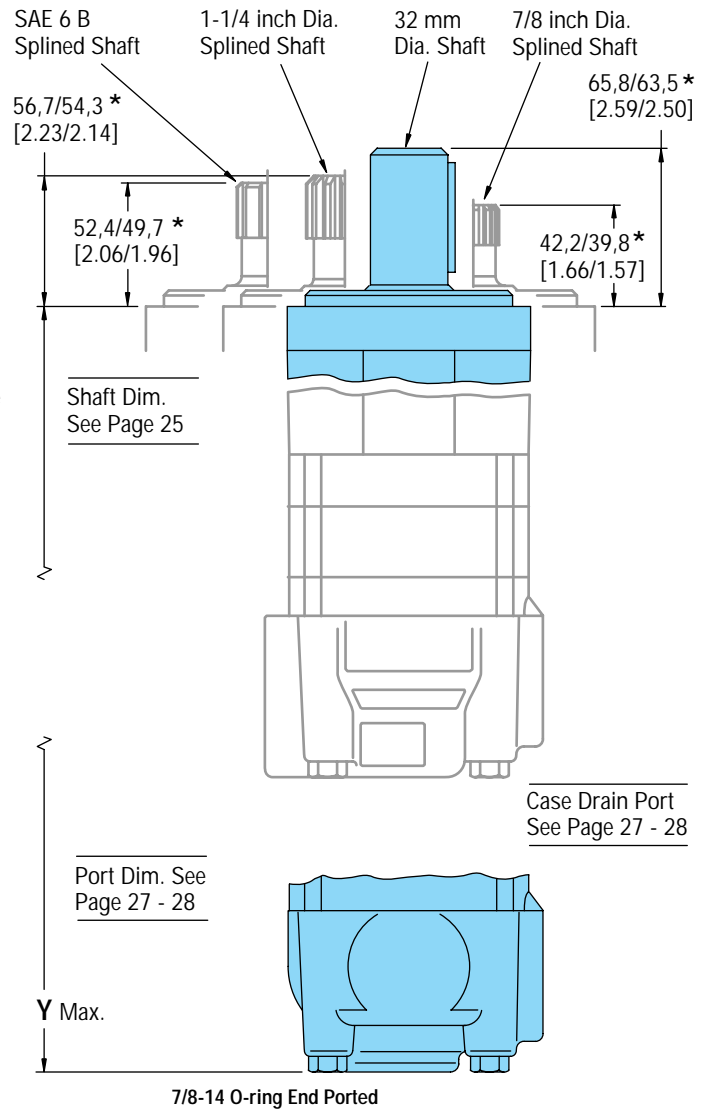
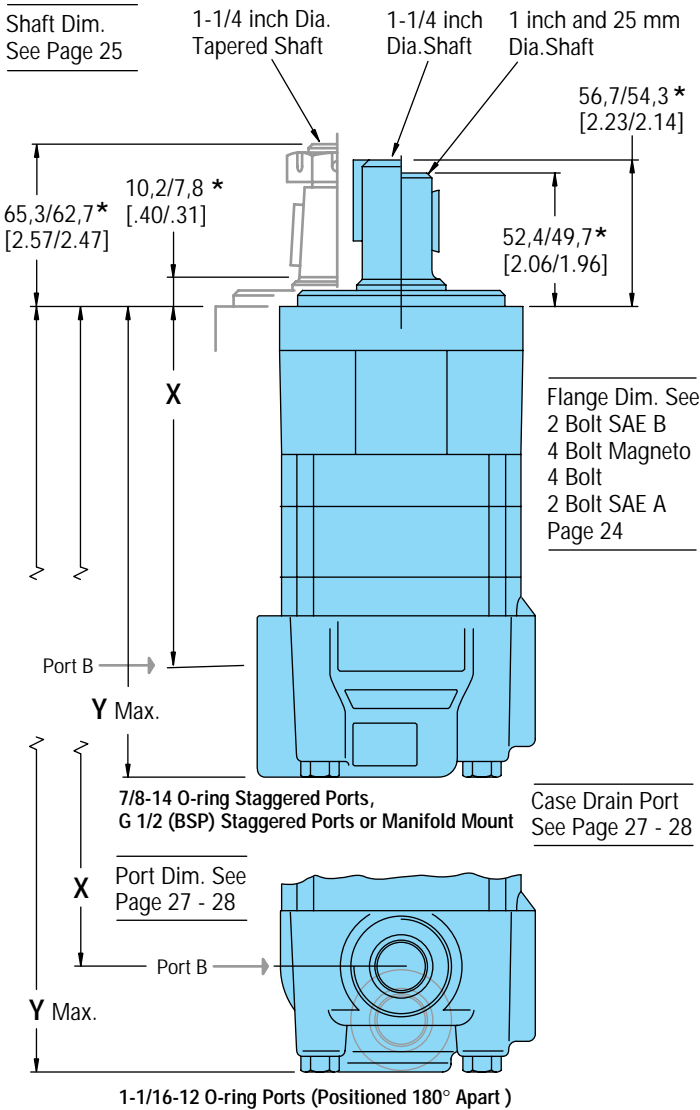

2000 Series Standard Motor with 7/8-14 O-ring Staggered Ports, G 1/2 (BSP) Staggered Ports or Manifold Mount

Displ. cm ³ /r [in ³ /r]	80 [4.9]	100 [6.2]	130 [8.0]	160 [9.6]	195 [11.9]	245 [14.9]	305 [18.7]	395 [24.0]	490 [29.8]
Dim. mm X [inch]	137,0 [5.40]	141,6 [5.58]	147,9 [5.83]	147,9 [5.83]	154,8 [6.10]	163,7 [6.45]	175,1 [6.90]	191,1 [7.53]	208,4 [8.21]
Dim. mm Y [inch]	184,5 [7.26]	189,0 [7.44]	195,4 [7.69]	195,4 [7.69]	202,2 [7.96]	211,1 [8.31]	222,6 [8.76]	238,6 [9.39]	255,8 [10.07]

2000 Series Standard Motor with 1-1/16-12 O-ring Ports (Positioned 180° Apart) and use Only Dim. Y for 7/8-14 O-ring End Ported Motors

Dim. mm X [inch]	139,3 [5.49]	143,9 [5.67]	150,2 [5.92]	150,2 [5.92]	157,1 [6.19]	166,0 [6.54]	177,4 [6.99]	193,4 [7.62]	210,7 [8.30]
Dim. mm Y [inch]	185,7 [7.31]	190,3 [7.49]	196,6 [7.74]	196,6 [7.74]	203,5 [8.01]	212,4 [8.36]	223,8 [8.81]	239,8 [9.44]	270,1 [10.12]

Standard Rotation
Viewed from Shaft End
Port A Pressurized — CW
Port B Pressurized — CCW

***Subtract 4,1/3,6 [.16/.14] when ordering motor with 4-bolt magneto flange**

Dimensions — 2000 Series Wheel Motor

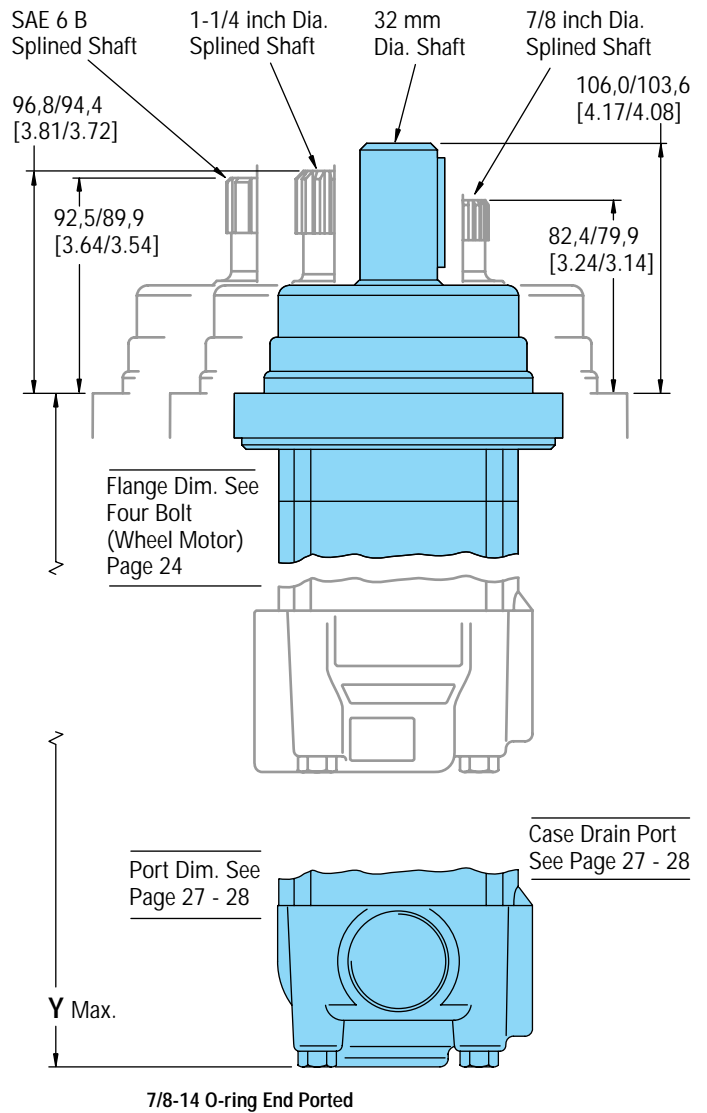
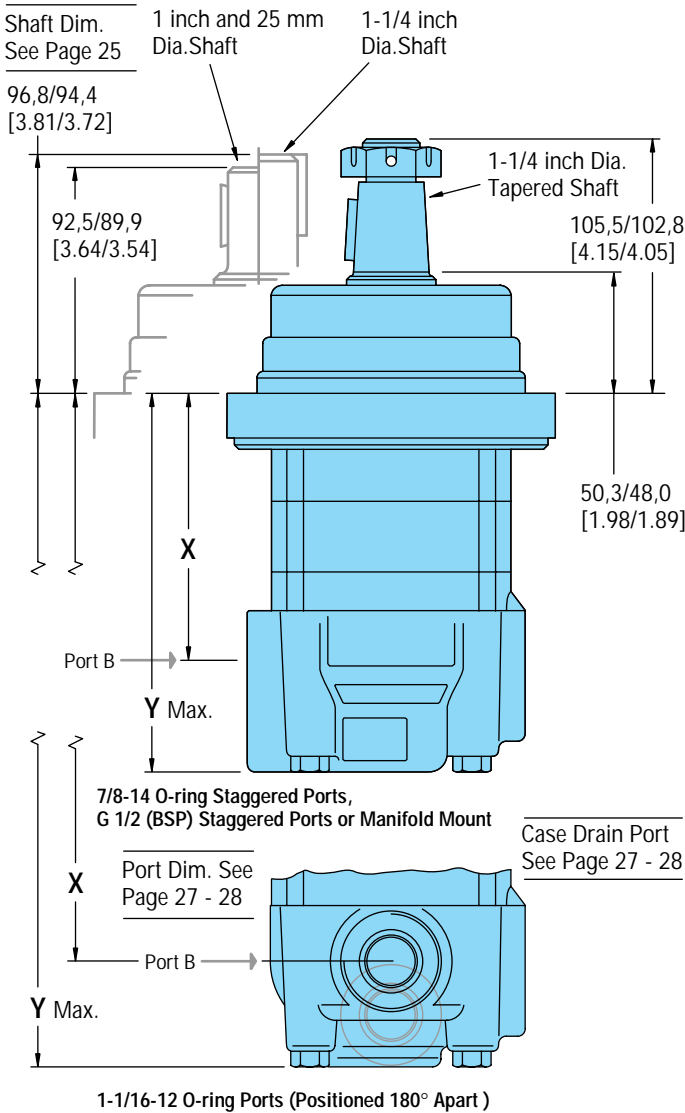

2000 Series Wheel Motor with 7/8-14 O-ring Staggered Ports, G 1/2 (BSP) Staggered Ports or Manifold Mount

Displ. cm ³ /r	80	100	130	160	195	245	305	395	490
[in ³ /r]	[4.9]	[6.2]	[8.0]	[9.6]	[11.9]	[14.9]	[18.7]	[24.0]	[29.8]
Dim. mm	96,9	101,4	107,8	107,8	114,6	123,5	135,0	151,0	168,2
X [inch]	[3.82]	[4.00]	[4.25]	[4.25]	[4.52]	[4.87]	[5.32]	[5.95]	[6.63]
Dim. mm	144,3	148,9	155,2	155,2	162,1	171,0	182,4	198,4	215,7
Y [inch]	[5.68]	[5.86]	[6.11]	[6.11]	[6.38]	[6.73]	[7.18]	[7.81]	[8.49]

2000 Series Wheel Motor with 1-1/16-12 O-ring Ports (Positioned 180° Apart) and use Only Dim. Y for 7/8-14 O-ring End Ported Wheel Motors

Dim. mm	99,1	103,7	110,1	110,1	116,9	125,8	137,4	153,4	170,7
X [inch]	[3.90]	[4.09]	[4.34]	[4.34]	[4.61]	[4.96]	[5.41]	[6.04]	[6.72]
Dim. mm	145,6	150,2	156,5	156,5	163,4	172,3	183,7	199,7	217,0
Y [inch]	[5.73]	[5.91]	[6.16]	[6.16]	[6.43]	[6.78]	[7.23]	[7.86]	[8.54]

Standard Rotation
Viewed from Shaft End
Port A Pressurized — CW
Port B Pressurized — CCW

Dimensions — 2000 Series Bearingless Motor

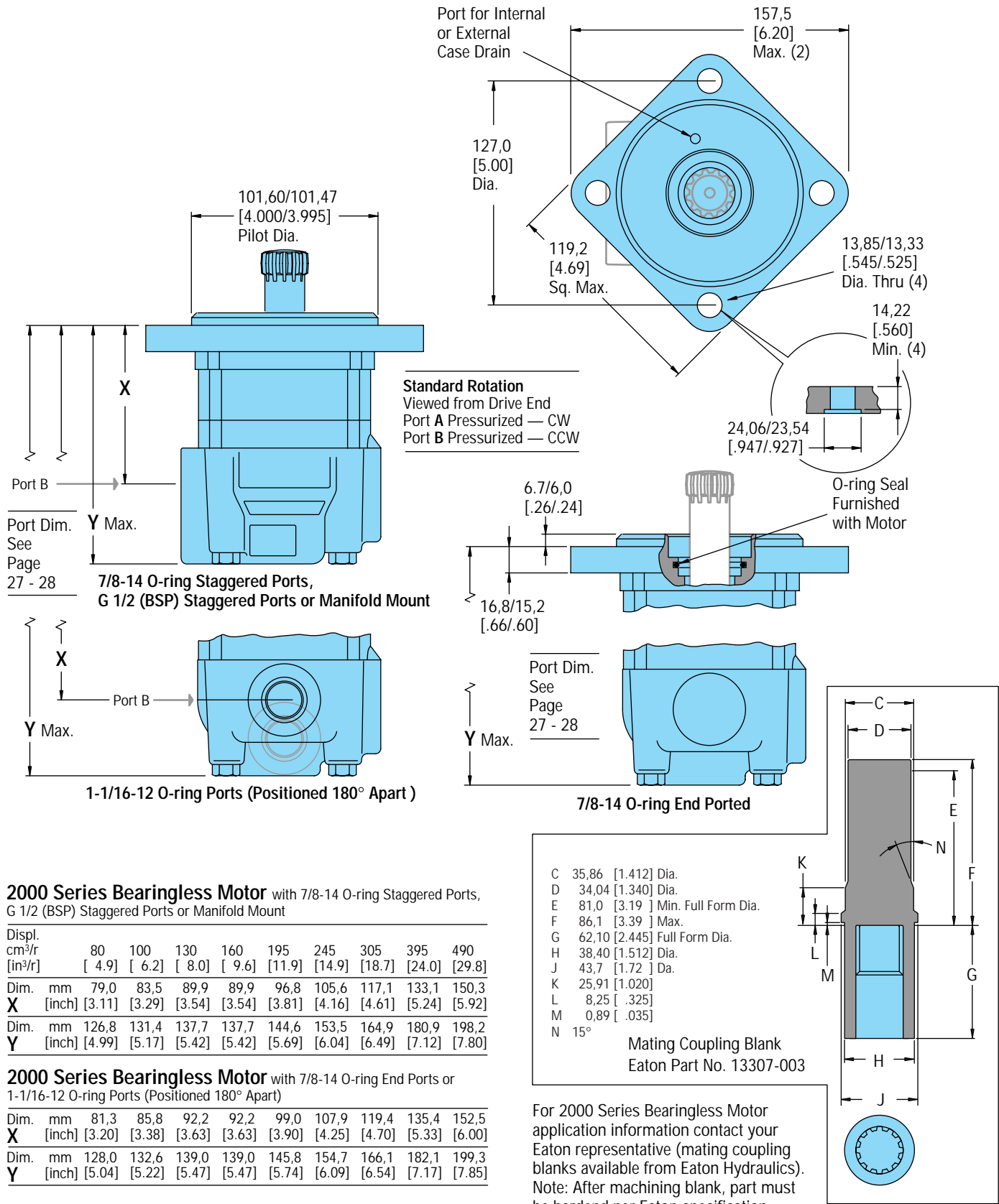

Bearingless Installation — 2000 Series

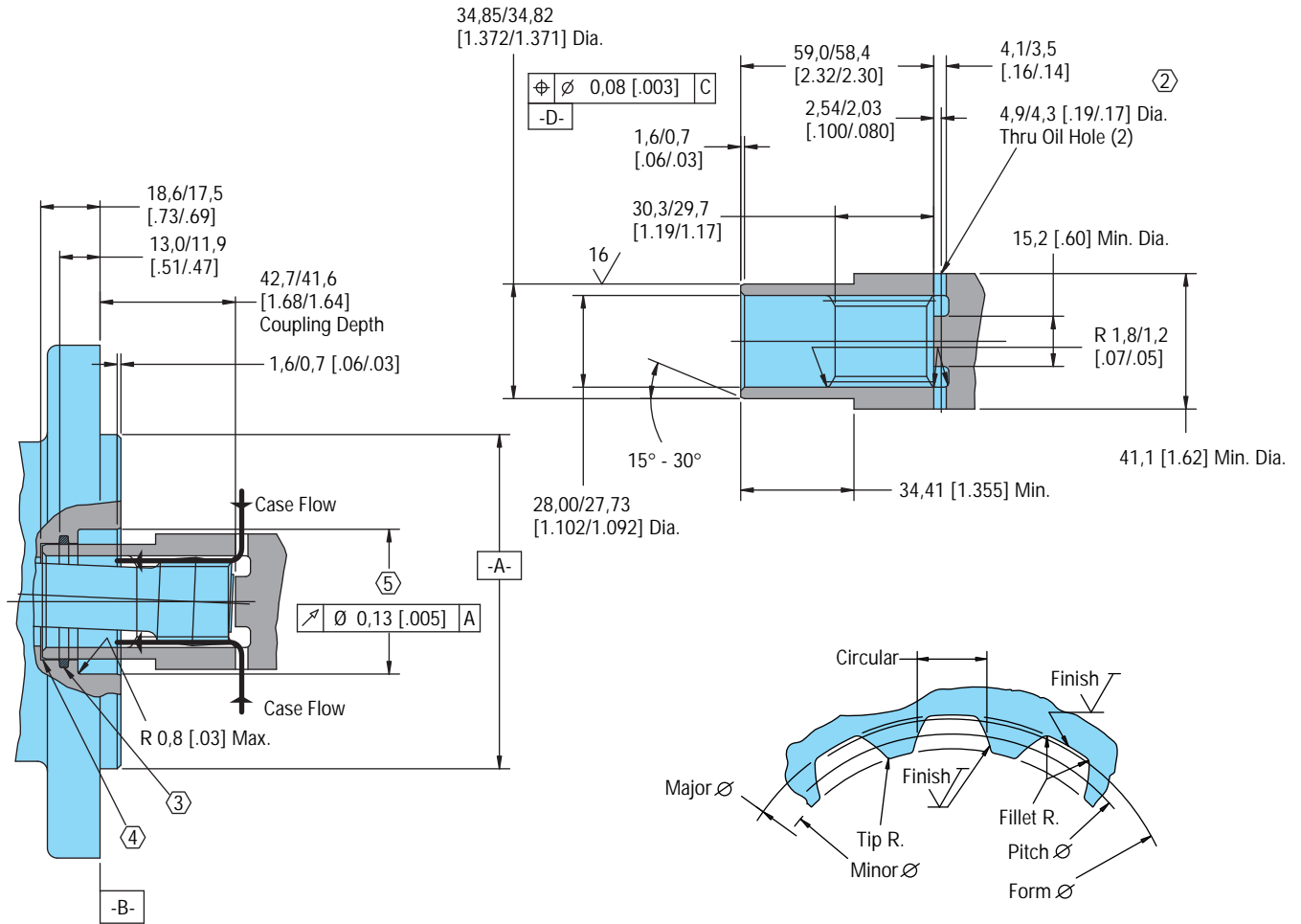

Spline Pitch — 12/24
 Pressure Angle — 30°
 Number of teeth — 12
 Class of Fit — Ref. 5
 Type of Fit — Side
 Pitch Diameter — Ref. 25,400000 [1.0000000] [©] 0,21 [0.008] [D]
 Base Diameter — Ref. 21,997045 [0.8660254]
 Major Diameter — (27,74 [1.092] Max. 27,59 [1.086] Min.)
 Minor Diameter — 23,097 - 23,224 [0.9093 - .9143]
 Form Diameter, Min. — 29,93 [1.060]
 Fillet Radius — 0,64 - 0,76 [0.025 - .030]
 Tip Radius — 0,25 - 0,38 [0.010 - .015]
 Finish — 1,6 (63)
 Involute Profile Variation — +0,000 -0,025 [+0.0000 -0.0010]
 Total Index Variation — 0,038 [0.0015]
 Lead Variation — 0,013 [0.0005]
 Circular Space Width:
 Maximum Actual — 4,318 [0.1700]
 Minimum Effective — 4,216 [0.1660]
 Maximum Effective — Ref. 4,270 [0.1681]
 Minimum Actual — Ref. 4,247 [0.1672]
 Dimension Between Two Pins — Ref. 19,020 - 19,190 [0.7488 - .7555]
 Pin Diameter — 4,496 [0.1770] Pins to Have 3,38 [0.133] Wide Flat for Root Clearance

- 1 Internal spline in mating part to be per spline data. Specification material to be ASTM A304, 8620H vacuum degassed alloy steel carburize to a hardness of 59-62 HRC with case depth (to 50HRC) of 0,076 - 1,02 [0.030 - .040]. Dimensions apply after heat treat.
- ② Mating part to have critical dimensions as shown. Oil holes must be provided and open for proper oil circulation.
- ③ Seal to be furnished with motor for proper oil circulation thru splines.
- ④ Some means of maintaining clearance between shaft and mounting flange must be provided.
- ⑤ Counterbore designed to adapt a standard sleeve bearing 35,010 - 35,040 [1.3784 - 1.3795] I.D. by 44,040 - 44,070 [1.7339 - 1.7350] O.D. (Oilite Bronze Sleeve Bearing AAM3544-22).

Dimensions — Mounting Options 2000 Series

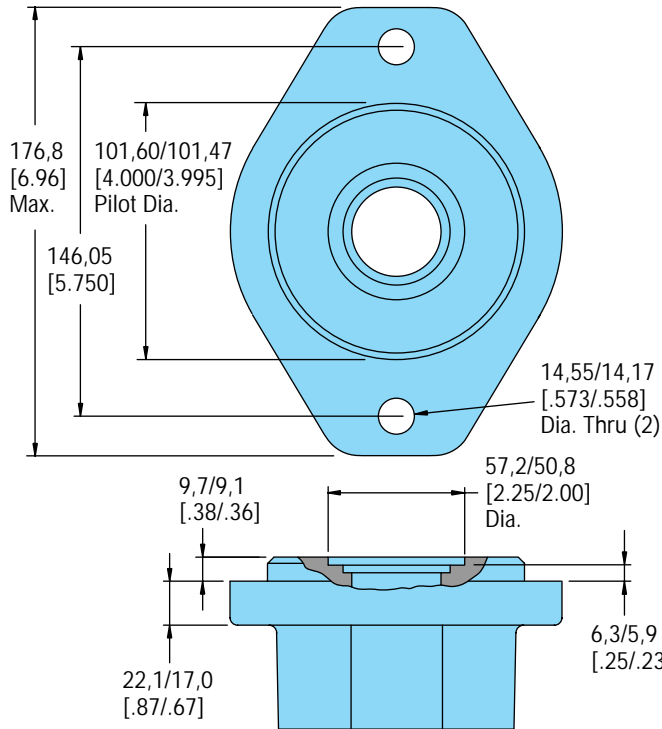

2 Bolt SAE B

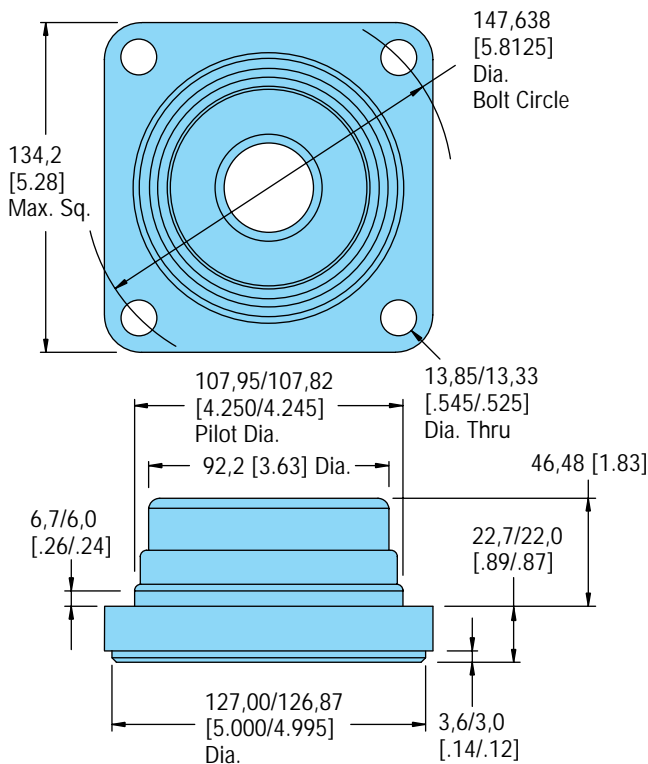

Four Bolt (Wheel Motor)

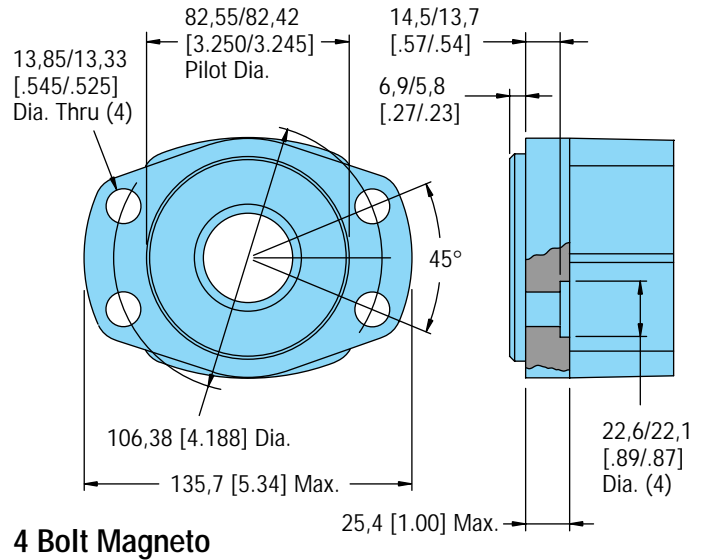

4 Bolt Magneto

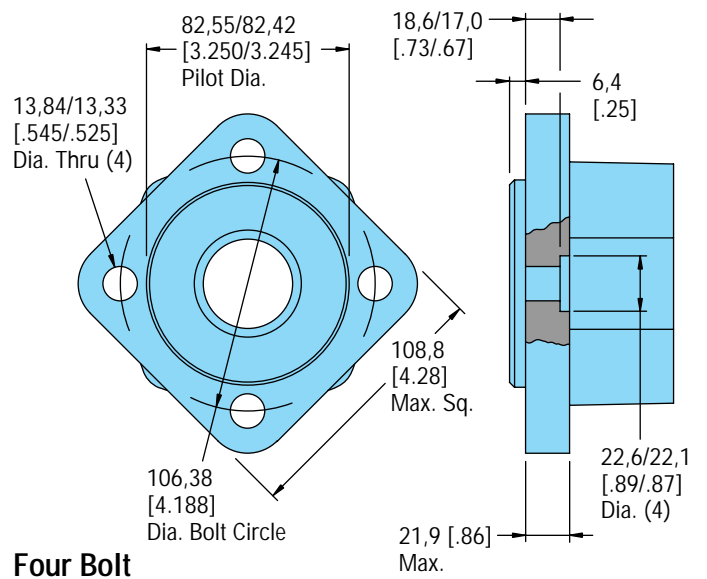

Four Bolt

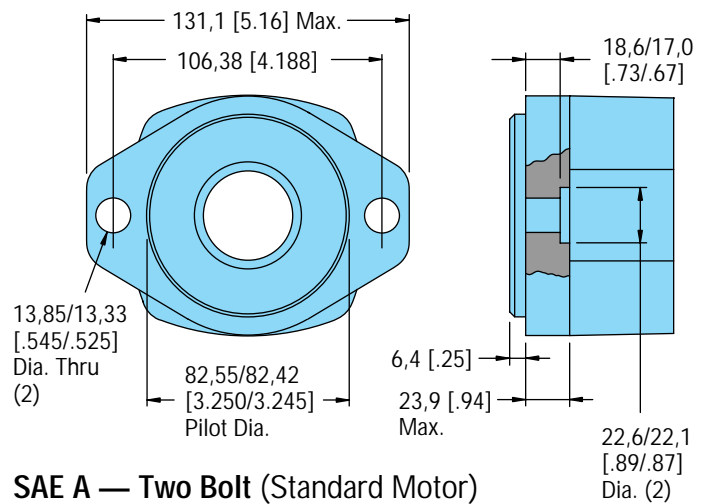

SAE A — Two Bolt (Standard Motor)

Dimensions — Shafts

2000 Series

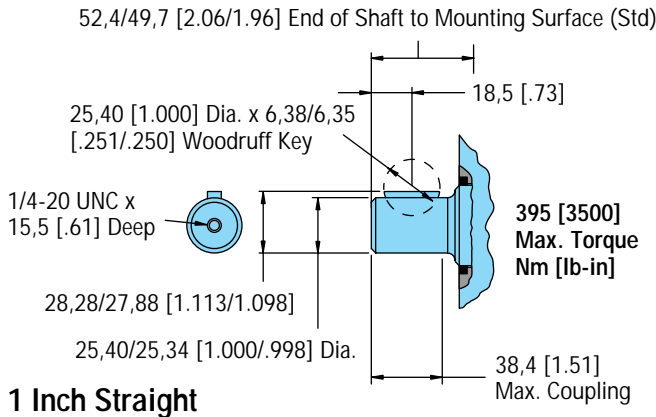

1 Inch Straight

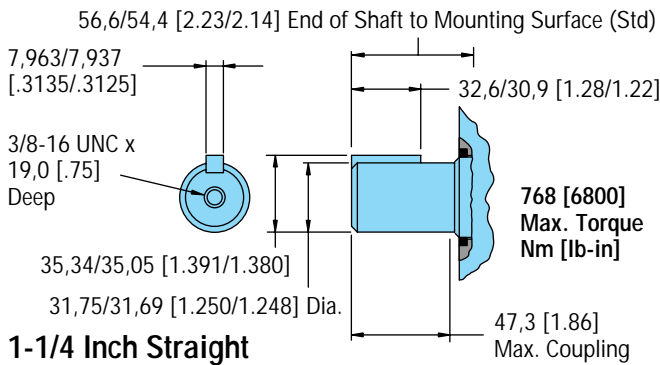

1-1/4 Inch Straight

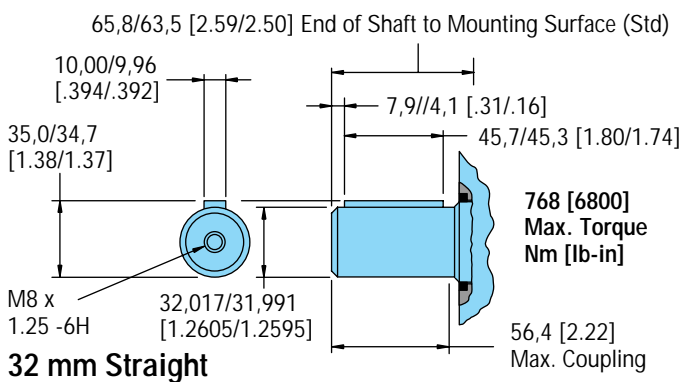

32 mm Straight

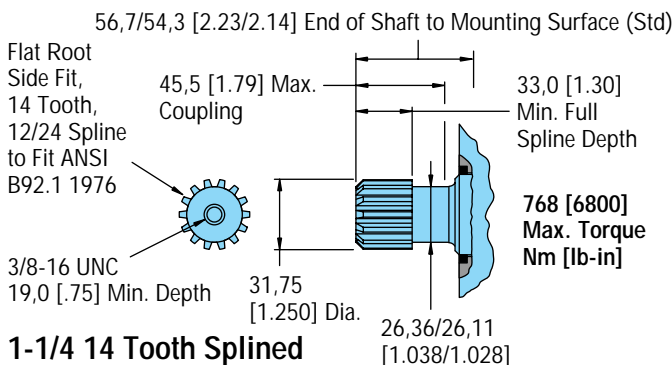

1-1/4 14 Tooth Splined

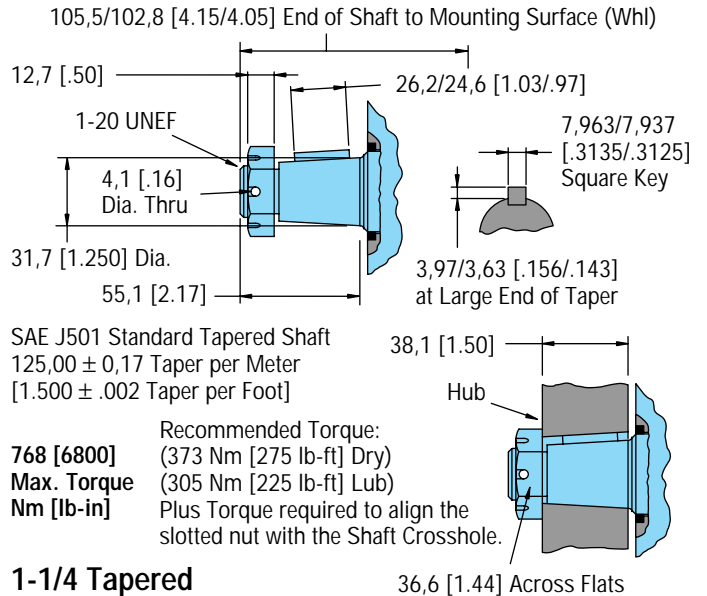

1-1/4 Tapered

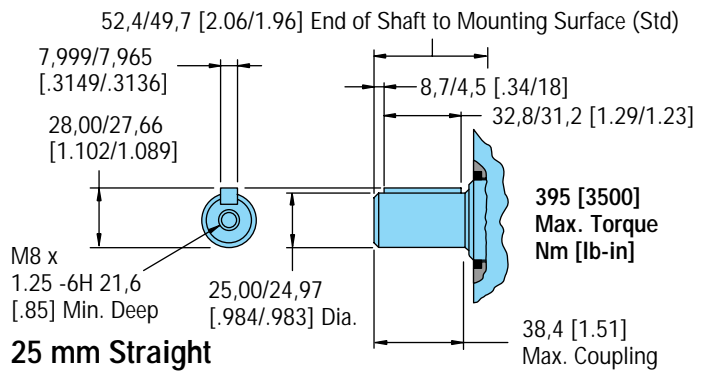

25 mm Straight

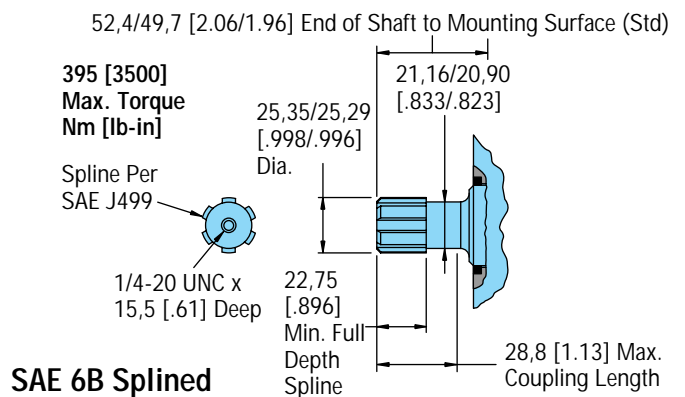

SAE 6B Splined

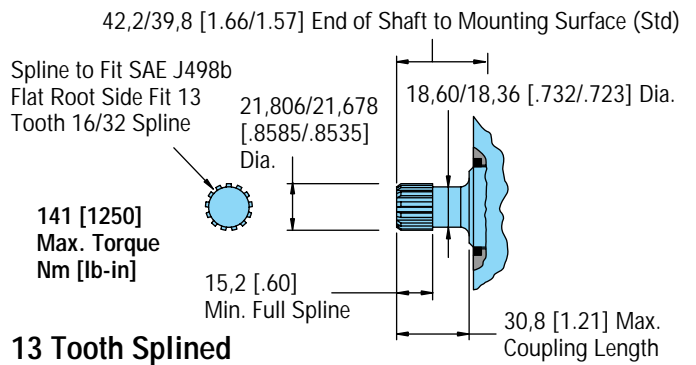

13 Tooth Splined

Shaft Side Load Capacity 2000 Series

These curves indicate the radial load capacity on the motor shaft(s) at various locations.

The curve is based on B 10 Bearing life (2000 hours or 12,000,000 shaft revolutions at 100 RPM) at rated output torque. To determine radial load at speeds other than 100 RPM, multiply the load values given on the bearing curve by the factors in the chart below.

RPM	Multiplication Factor
50	1.23
100	1.00
200	.81
300	.72
400	.66
500	.62
600	.58
700	.56
800	.54

For 3,000,000 Shaft revolutions or 500 hours — Increase these shaft loads 52%.

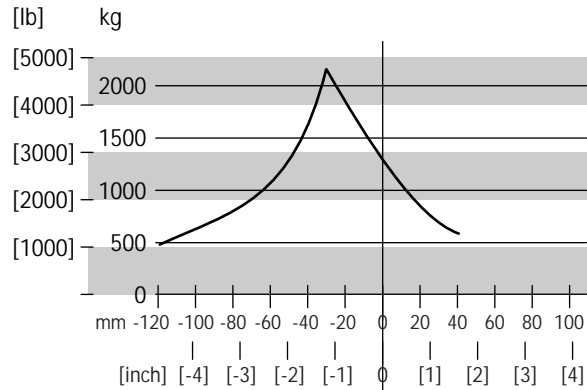

Wheel Motor
Tapered
Shaft

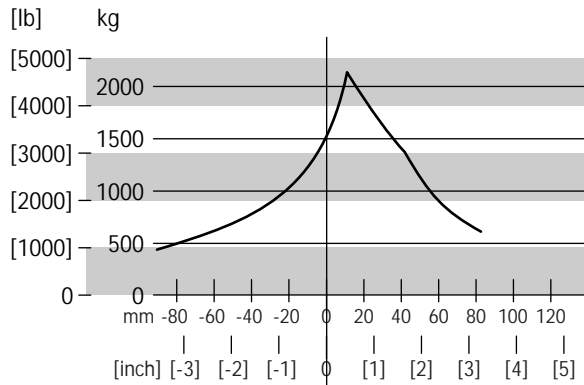
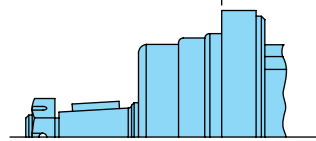

Standard Motor
1-1/4 Inch and
32 mm Straight
Shaft

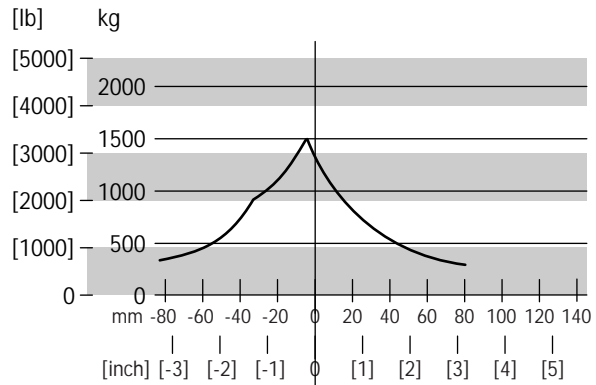
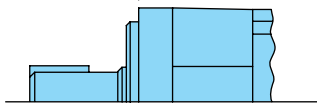

Standard Motor
1 Inch Straight
Shaft

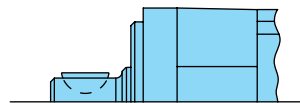

Dimensions — Ports 2000 Series

Standard Rotation — 2000 Series
Viewed from Shaft End
Port A Pressurized — CW
Port B Pressurized — CCW

**7/8-14 O-ring Ports (2)
or G 1/2 (BSP) Ports (2)**

Case Drain Location — Staggered Ports (Including Manifold Mount)

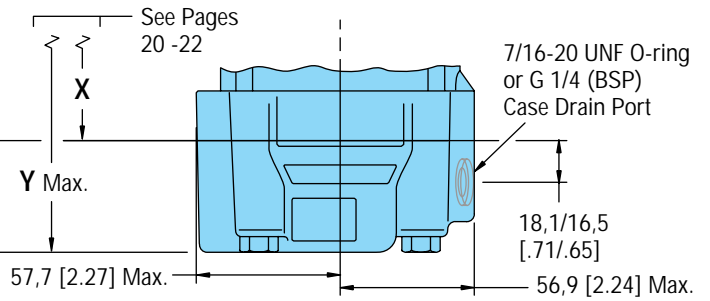
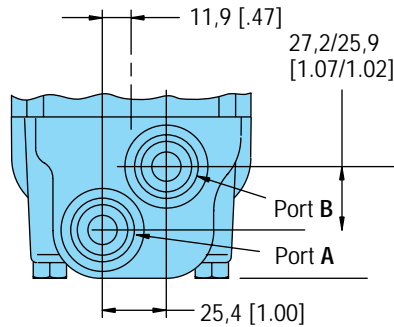
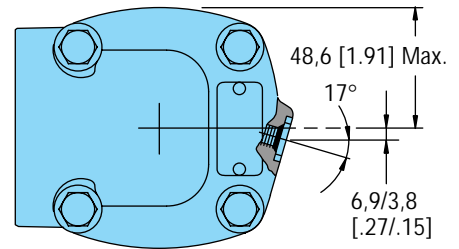

Manifold Mount

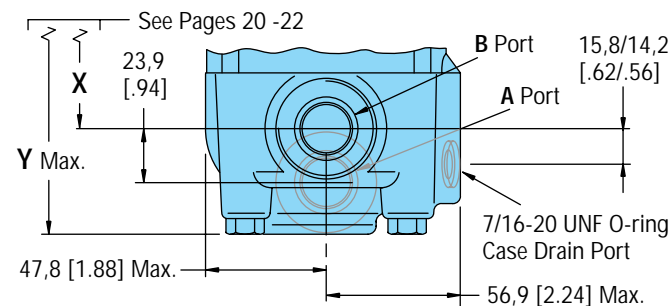
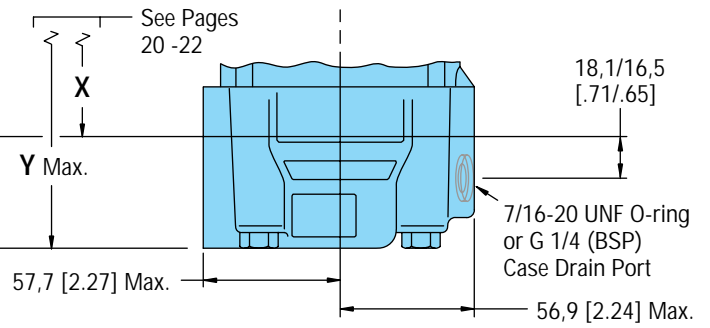
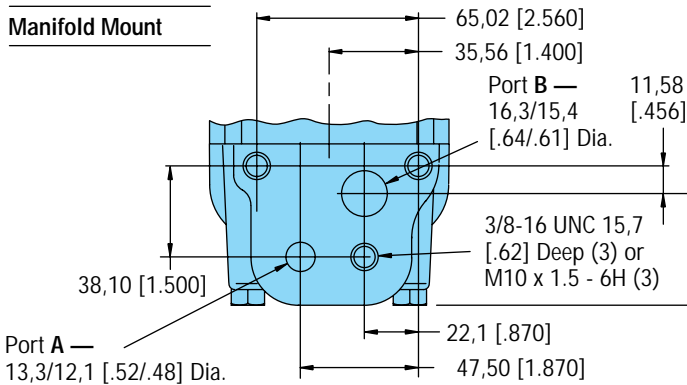

7/8-14 O-ring End Ports (2)

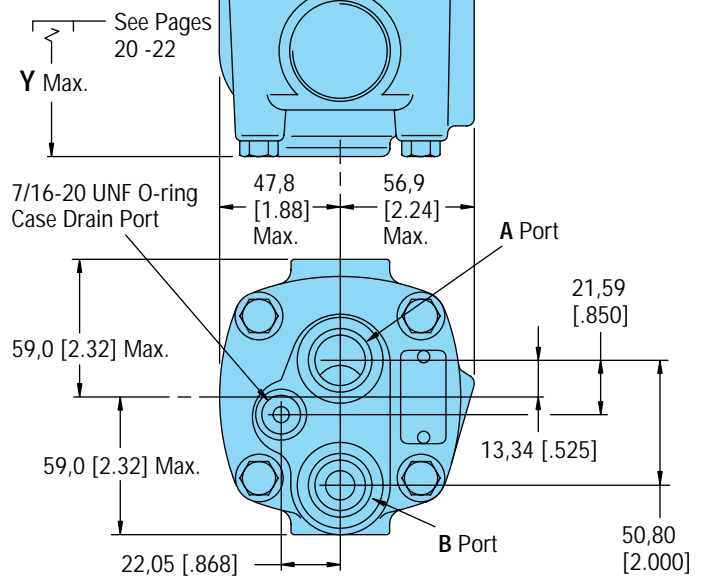

**1-1/16-12 O-ring Ports (2)
Positioned 180° Apart**

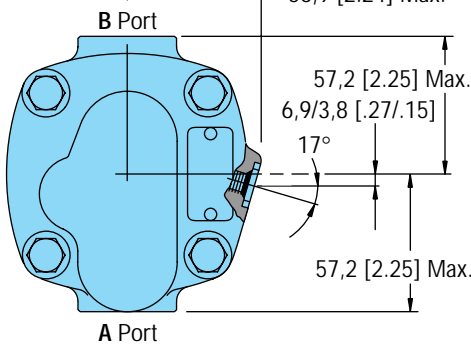

Dimensions — Ports

2000 Series with Shuttle

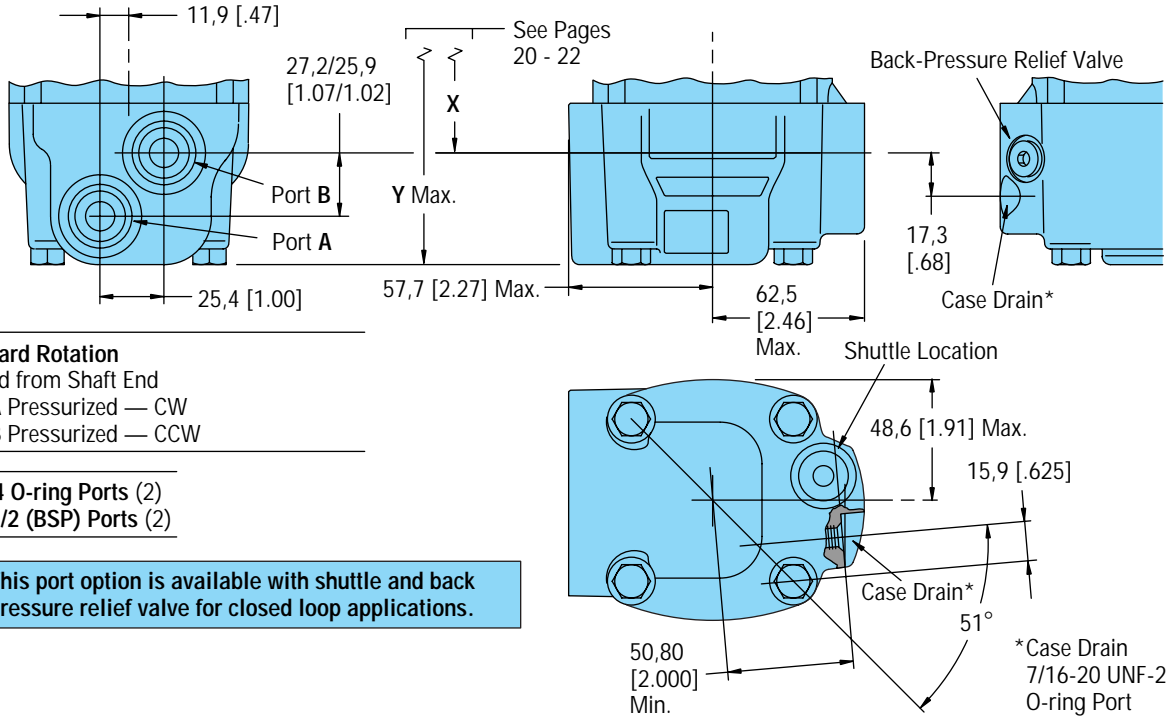

Standard Rotation
 Viewed from Shaft End
 Port A Pressurized — CW
 Port B Pressurized — CCW

7/8-14 O-ring Ports (2)
 or G 1/2 (BSP) Ports (2)

This port option is available with shuttle and back pressure relief valve for closed loop applications.

7/8-14 O-ring End Ports (2)

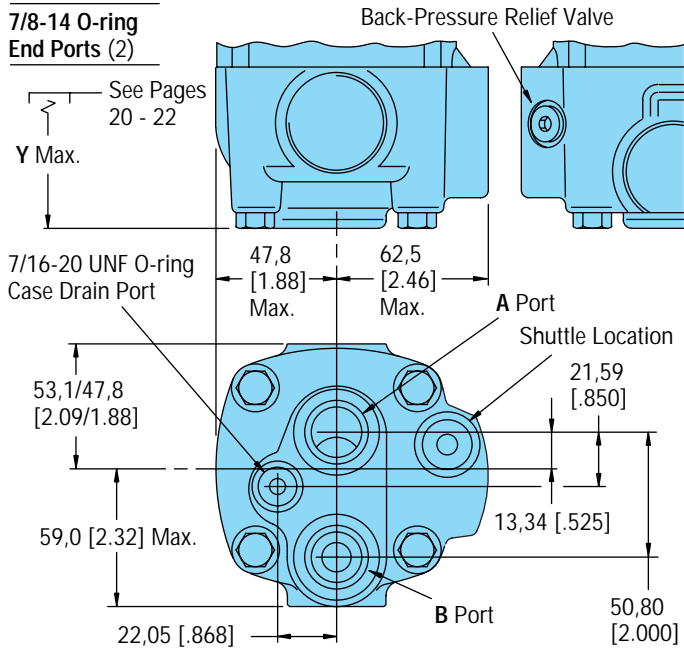

This port option is available with shuttle and back pressure relief valve for closed loop applications.

Product Numbers 2000 Series

Product Numbers—2000 Series

Use digit prefix —104-, 105-, or 106- plus four digit number from charts for complete product number—Example 106-1043.

Orders will not be accepted without three digit prefix.

Mounting	Shaft	Ports	Displacement cm ³ /r [in ³ /r] and Product Number								
			80 [4.9]	100 [6.2]	130 [8.0]	160 [9.6]	195 [11.9]	245 [14.9]	305 [18.7]	395 [24.0]	490 [29.8]
2 Bolt SAE A Flange	1 inch Straight	7/8-14 O-ring Staggered	104-1001	-1002	-1003	-1004	-1005	-1006	-1007	-1143	—
		1-1/16—12 O-ring 180° Apart	104-1037	-1038	-1039	-1040	-1041	-1042	-1043	-1044	—
	1-1/4 Inch Straight	7/8-14 O-ring Staggered	104-1022	-1023	-1024	-1025	-1026	-1027	-1028	-1228	-1420
		1-1/16—12 O-ring 180° Apart	104-1061	-1062	-1063	-1064	-1065	-1066	-1067	-1068	-1421
	1-1/4 Inch 14 T Splined	7/8-14 O-ring Staggered	104-1029	-1030	-1031	-1032	-1033	-1034	-1035	-1229	-1422
		1-1/16—12 O-ring 180° Apart	104-1087	-1088	-1089	-1090	-1091	-1092	-1093	-1094	-1423
2 Bolt SAE B Flange	1-1/4 Inch Straight	7/8-14 O-ring Staggered	104-1200	-1201	-1202	-1203	-1204	-1205	-1206	-1207	—
	1-1/4 Inch Involute SAE C Splined	7/8-14 O-ring Staggered	104-1208	-1209	-1210	-1211	-1212	-1213	-1214	-1215	—
	1 Inch SAE 6B Splined	7/8-14 O-ring Staggered	104-1193	-1194	-1195	-1196	-1197	-1198	-1199	—	—
	7/8 Inch SAE B Splined	7/8-14 O-ring Staggered	104-1216	-1217	-1218	-1219	-1220	—	—	—	—
Standard with 4 Bolt Square Flange	32 mm Straight	G 1/2 (BSP)	104-1384	-1385	-1386	-1387	-1388	-1389	-1390	-1391	—
	1-1/4 Inch 14 T Splined	G 1/2 (BSP)	104-1376	-1377	-1378	-1379	-1380	-1381	-1382	-1383	—
Wheel Motor	1-1/4 Inch Straight	7/8-14 O-ring Staggered	105- —	—	—	—	—	—	—	—	-1148
		1-1/16—12 O-ring 180° Apart	105- —	—	—	—	—	—	—	—	—
	32 mm Straight	G 1/2 (BSP)	105-1134	-1135	-1136	-1137	-1138	-1139	-1140	-1141	—
	1-1/4 Inch Tapered	7/8-14 O-ring Staggered	105-1001	-1002	-1003	-1004	-1005	-1006	-1007	-1060	-1152
		1-1/16—12 O-ring 180° Apart	105-1071	-1072	-1073	-1074	-1075	-1076	-1077	-1078	—
	1-1/4 Inch 14 T Splined	7/8-14 O-ring Staggered	105-1029	-1030	-1031	-1032	-1033	-1034	-1035	-1096	—
1-1/16—12 O-ring 180° Apart		105-1079	-1080	-1081	-1082	-1083	-1084	-1085	-1086	—	
Bearingless		7/8-14 O-ring Staggered	106-1008	-1009	-1010	-1011	-1012	-1013	-1014	-1015	-1047
		G 1/2 (BSP)	106-1038	-1039	-1040	-1041	-1042	-1043	-1044	-1045	—

106-1043

Product Numbers—2000 Series Motors with Corrosion Protection

Mounting	Shaft	Ports	Displacement cm ³ /r [in ³ /r] and Product Number								
			80 [4.9]	100 [6.2]	130 [8.0]	160 [9.6]	195 [11.9]	245 [14.9]	305 [18.7]	395 [24.0]	490 [29.8]
2 Bolt SAE A Flange	1 inch Straight	7/8-14 O-ring Staggered	104-1528	-1529	-1530	-1531	-1532	-1533	-1534	-1519	-1535
	1-1/4 Inch Straight	7/8-14 O-ring Staggered	104-1516	-1536	-1537	-1538	-1539	-1452	-1479	-1509	-1489

For 2000 Series Motors with a configuration *Not Shown* in the charts above: Use model code number system on page 30 to specify product in detail.

Disk Valve Hydraulic Motors

Model Code for 2000 Series Motors

The following 14-digit coding system has been developed to identify all of the configuration options for the 2000 Series motor. Use this model code to specify a motor with the desired features. All 14-digits of the code must be present when ordering. You may want to photocopy the matrix below to ensure that each number is entered in the correct box.

Model Code — 2000 Series Disc Valve Motor

1	2	3	4	5	6	7	8	9	10	11	12	13	14	15	16	17	18	19	20	21	22	23	24	
M	0	2																						

Position 1 **Product Series**

M Motor

Position 2, 3 **2000 Series**

02 2000 Series

Position 4, 5 **Displacement cm³/r [in³/r]**

05 80 [4.9]	15 245 [14.9]
06 100 [6.2]	19 305 [18.7]
08 130 [8.0]	24 395 [24.0]
10 160 [9.6]	30 490 [29.8]
12 195 [11.9]	

Position 6, 7 **Mounting Flange**

AD 4 Bolt (Bearingless) 101,6 [4.00] Pilot Dia. and 13,59 [.535] Dia. Mounting Holes on 127,0 [5.00] Dia. B.C.

AC 2 Bolt SAE A (Std.) 82,5 [3.25] Pilot Dia. and 13,59 [.535] Dia. Mtg. Holes on 106,4 [4.19] Dia. B.C.

AB 4 Bolt (Wheel) 108,0 [4.25] Pilot Dia. and 13,59 [.535] Dia. Mounting Holes on 147,6 [5.81] Dia. B.C.

AH 4 Bolt (Standard) 82,5 [3.25] Pilot Dia. and 14,59 [.535] Dia. Mounting Holes on 106,4 [4.19] Dia. B.C.

AJ 4 Bolt Magneto (Std.) 82,5 [3.25] Pilot Dia. and 13,59 [.535] Dia. Mtg. Holes on 106,4 [4.19] Dia. B.C.

AF 2 Bolt SAE B (Std.) 101,6 [4.00] Pilot Dia. and 14,35 [.565] Dia. Mtg. Holes on 146,0 [5.75] Dia. B.C.

AP 4 Bolt (wheel compatible for HAYES BRAKE) 107,9 [4.25] Pilot Dia. and 13,59 [.535] Dia. Mounting Holes on 147,6 [5.81] Dia. B.C. with Turned Down Housing to 88,9 [3.50] Dia.

Position 8, 9 **Output Shaft**

00 Bearingless

01 1 inch Dia. Straight with Woodruff Key, 1/4-20 Threaded Hole and 38,4 [1.51] Max. Coupling Length

02 1-1/4 inch Dia. Straight with Straight Key, 3/8-16 Threaded Hole and 47,3 [1.86] Max. Coupling Length

23 32 mm dia. Straight with Straight Key, M8 x 1,25 -6H Threaded Hole and 56,4 [2.22] Max. Coupling Length

04 1-1/4 inch Dia. Splined 14 T, 3/8-16 Threaded Hole and 33,0 [1.30] Min. Full Spline Length and 45,5 [1.79] Max. Coupling Length

03 1-1/4 inch Dia. Tapered with Straight Key and Nut

05 1 inch SAE 6B Splined 6T, 1/4-20 Threaded Hole and 22,8 [.90] Min. Full Spline Length and 28,8 [1.13] Max. Coupling Length

07 7/8 inch Dia. Splined 13T, 15,2 [.60] Min. Full Spline Length and 30,8 [1.21] Max. Coupling Length

24 1-1/4 inch Dia. Straight with Straight Key, 3/8-16 Threaded Hole and Corrosion Resistant (seal area to shaft end)

25 1-1/4 inch Dia. Tapered with Straight Key and Nut, Corrosion Resistant (under seal area only)

26 25 mm Dia. Straight with Straight Key, M8 x 1,25 -6H Threaded Hole and 38,4 [1.51] Max. Coupling Length

Position 10, 11 **Port Type**

AA 7/8-14 UNF -2B SAE O-ring (Staggered)

AG G 1/2 BSP Straight Thread ports (Staggered)

AB Manifold Mount with 3/8-16 UNC Mounting Threads (3)

AE Manifold Mount with M10 x 1,5 -6H Mounting Threads (3)

AD 7/8-14 UNF -2B SAE O-ring (End Ports)

AF 1-1/16 - 12 UN-2B O-ring ports (Positioned 180° Apart)

Position 12, 13 **Case Flow**

(Shuttles available with port code AA or AD only)

01 7/16-20 UNF -2B SAE O-ring (Case Drain)

02 G 1/4 (BSP) straight thread port (Case Drain)

04 Shuttle Valve with 7/16-20 UNF -2B SAE O-ring (Case Drain)

05 Shuttle Valve with G 1/4 (BSP) straight thread port (Case Drain)

Position 14 **Low Pressure Relief**

(LPR available with a combination of case flow code 04 or 05 and port code AA or AD only)

0 None

A Set @ 4,5 bar [65 psi]

B Set @ 15,2 bar [220 psi]

C Set @ 20,7 bar [300 psi]

Position 15, 16 **Valve Option**

00 None

Position 17, 18 **Accessories**

00 None

AA Seal Guard

AB Speed Sensor (Std. With Weatherpack shroud connector)

AH Speed Sensor (Std. With M12 connector)

AL Quadrature Speed Sensor Version 2 with M12

Position 19, 20 **Special Features (Hardware)**

00 None

01 Viton Seals

10 Viton Shaft Seal

Position 21 **Special Features (Assembly)**

0 None

A Flange Rotated 90°

B Reverse Rotation

Position 22 **Paint/Special Packaging**

0 No Paint

A Painted Low Gloss Black

B Corrosion Protected

Position 23 **Eaton Assigned Code when Applicable**

0 Assigned Code

Position 24 **Eaton Assigned Design Code**

0 Assigned Design Code

Two Speed Motor — 2000 Series

The Eaton 2000 Series motors are available with an integral two speed feature that changes the displacement in a ratio of 1 to 2 and shifts the motor from a low speed high torque (LSHT) mode to a high speed low torque (HSLT) mode. The open center selector valve shifts the speed mode from low to high speed when pilot pressure of 6.9 Δ Bar [100 Δ PSI] minimum is applied to the pilot port (6.9 Bar [100 PSI] higher than case pressure). In the high speed mode torque values are approximately one half with twice the speed of the conventional 2000 Series single speed motors.

An external two position three way valve is required for shifting the pilot pressure port between signal pressure (HSLT) and low pressure (LSHT)

Two speed motors are available with a return line closed center shuttle for closed circuit applications.

Low speed high torque mode is the normal position of the speed selector valve. When a differential pressure is supplied to the pilot port and 6.9 Bar [100 PSI] is reached, the selector valve overcomes the return spring force and the spool shifts to the high speed mode. The oil in the opposite side of the spool is drained internally. Pressure between the pilot supply and case drain or return line (depending on open or closed circuit system) must be maintained to keep the motor in the high speed mode.

When pilot pressure is removed from the pilot port the pressure in the pilot end of the spool valve is relieved and drained back through this three way valve, the spring force returns the spool valve to LSHT position.

Pilot pressure may come from any source that will provide uninterrupted pressure during the high speed mode operation. Pilot pressure 6.9 Δ Bar [100 Δ PSI] minimum, up to the full operating pressure of the motor.

In normal LSHT operation the Char-Lynn two speed motor will function with equal shaft output in either direction (CW or CCW), the same as the single speed Char-Lynn disc valve motors.

However, to prevent cavitation in the HSLT mode, the preferred direction of shaft rotation is counter clockwise (port B pressurized). This unique disc valve is not symmetrical in porting the fluid for the HSLT mode. Consequently, when the pressure is reversed for HSLT CW rotation, cavitation can occur. Installing a restriction (14 - 34 Bar [200 - 500 PSI]) in the hydraulic line that connects port B will prevent cavitation (see page 32).

If you are operating in a critical area and a restriction in the hydraulic line causes concern, these two speed motors can be ordered timed with CW preferred HSLT shaft rotation. Hence, with this option port B will have to be pressurized for CW preferred HSLT shaft rotation. The restriction recommended for the line connecting port B remains unchanged. Finally in closed circuit applications a hydraulic line restriction is not required. Instead, the charge pump can be used to supply and maintain a minimum pressure of 14 Bar [200 PSI].

Note: Be certain in closed loop applications that the charge pump when used for back pressure on the B port, has sufficient displacement to maintain charge pressure especially in dynamic braking or overrunning load conditions.

Important! Due to potential problems in maintaining charge pump pressure at port B for uninterrupted back pressure during dynamic braking, Eaton does not recommend the two speed motor where overrunning conditions may exist.

Performance Data Two Speed Motor — 2000 Series

In the high speed mode torque values are approximately one half with twice the speed of the conventional 2000 Series single speed motors. In the low speed mode torque and speed values are the same as the conventional 2000 Series motors (see Performance Data on pages 15-19). For Two Speed Motor Specifications, Dimensions, and Product Numbers see pages 33 through 35.

Two Speed Motor — 2000 Series

Pump Pressure and Return, and
Shaft Rotation Directional Control Valve

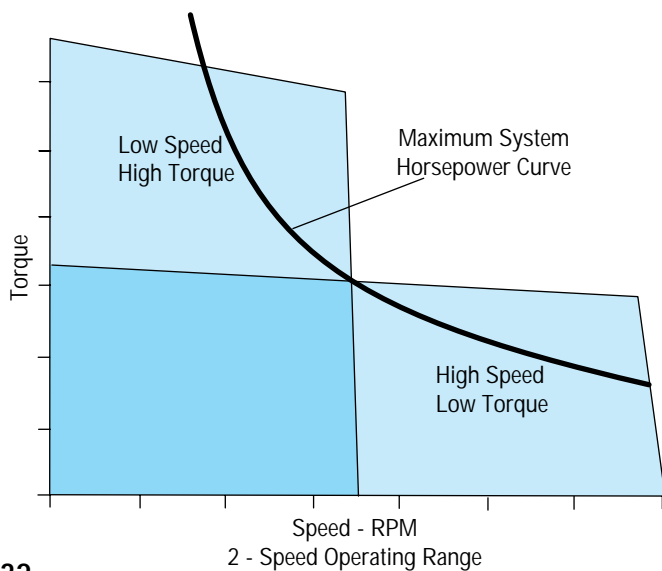
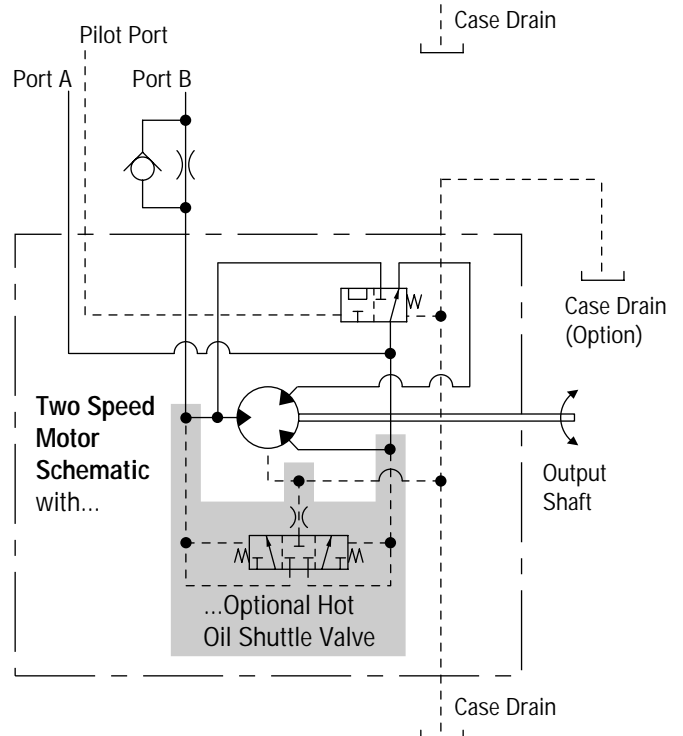
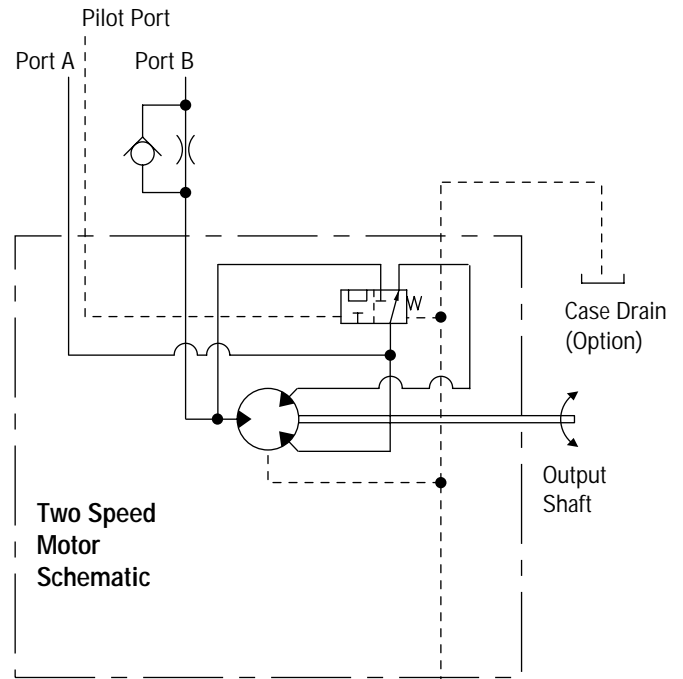
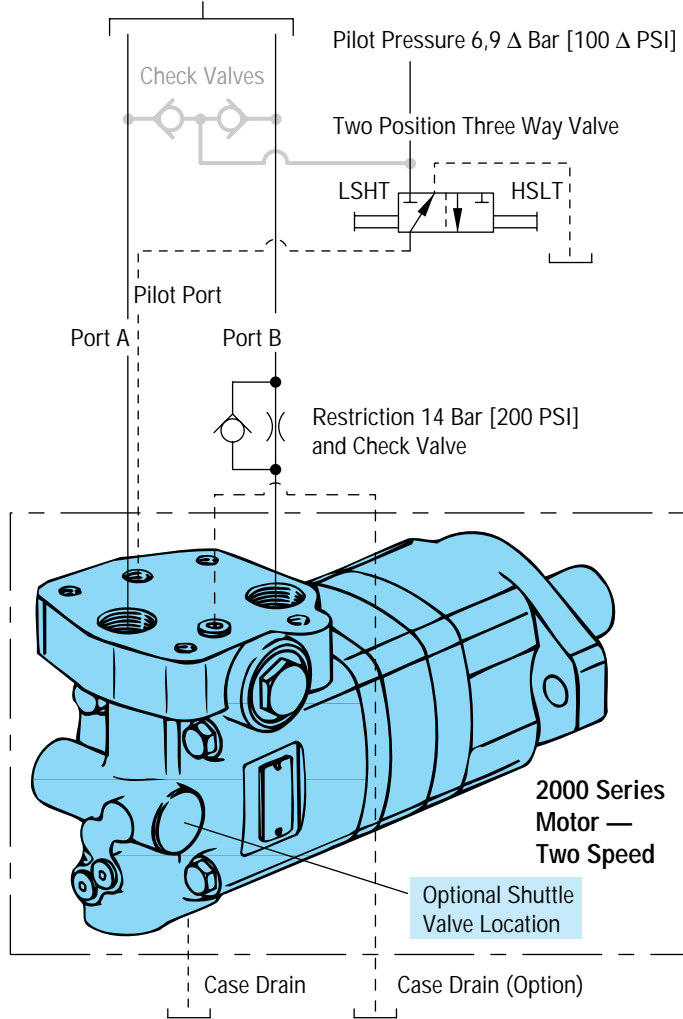

Specifications

Two Speed Motor — 2000 Series

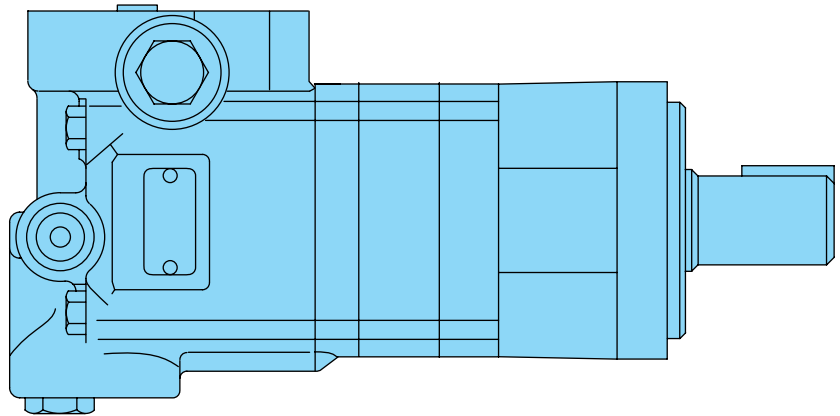

Specification Data—2000 Series Two Speed

Displ. cm ³ /r. [in ³ /r]	High Speed Mode	40 [2.45]	50 [3.1]	65 [4.0]	80 [4.8]	95 [5.95]	120 [7.45]	155 [9.35]	195 [12.0]	245 [15.0]
	Low Speed Mode	80 [4.9]	100 [6.2]	130 [8.0]	160 [9.6]	195 [11.9]	245 [14.9]	305 [18.7]	395 [24.0]	490 [29.8]
Max. Speed (RPM) @ Continuous Flow	High Speed Mode	1000	1000	990	860	700	560	450	350	230
	Low Speed Mode	500	500	495	430	350	280	225	175	115
Flow LPM [GPM]	High Speed Mode	45 [12]	55 [15]	70 [19]	75 [20]	75 [20]	75 [20]	75 [20]	75 [20]	75 [20]
	Low Speed Mode	45 [12]	55 [15]	70 [19]	75 [20]	75 [20]	75 [20]	75 [20]	75 [20]	75 [20]
Torque Nm [lb-in] ★ 1-1/4 Inch or 32 mm Dia. Shaft	High Speed Mode	Continuous 100 [880]	125 [1115]	165 [1450]	195 [1725]	240 [2150]	300 [2675]	380 [3350]	365 [3225]	448 [3970]
	Intermittent	145 [1300]	185 [1660]	240 [2150]	240 [2150]	300 [2650]	375 [3330]	440 [3900]	445 [3940]	486 [4300]
Torque Nm [lb-in] ★ 1-1/4 Inch or 32 mm Dia. Shaft	Low Speed Mode	Continuous 235 [2065]	295 [2630]	385 [3420]	455 [4040]	540 [4780]	660 [5850]	760 [6750]	770 [6840]	845 [7470]
	Intermittent	345 [3040]	445 [3950]	560 [4970]	570 [5040]	665 [5890]	820 [7250]	885 [7820]	925 [8170]	930 [8225]
Pressure Δ Bar [Δ PSI] ★ 1-1/4 Inch or 32 mm Dia. Shaft	Continuous	205 [3000]	205 [3000]	205 [3000]	205 [3000]	205 [3000]	205 [3000]	205 [3000]	155 [2250]	120 [1750]
	Intermittent	310 [4500]	310 [4500]	310 [4500]	260 [3750]	260 [3750]	260 [3750]	240 [3500]	190 [2750]	140 [2000]

Maximum Case Pressure - without Case Drain * — 140 Bar [2000 PSI]

High Speed Mode (Reduced Motor Displacement)

Low Speed Mode (Full Motor Displacement)

Maximum torque and flow must not occur simultaneously. For permissible continuous and intermittent operating combinations of pressure and flow refer to performance data on pages 15-19 (LSHT only).

★ **Maximum torque for 1 inch shaft** — 395 Nm [3500 lb-in] Continuous and 485 Nm [4300 lb-in] intermittent.

* For back pressure over 140 Bar [2000 PSI] use an external case drain. Install case drain lines so that the motor case remains filled at all times.

Maximum inlet pressure — 310 Bar [4500 PSI]. Do not exceed Δ pressure rating (see chart above).

* **Maximum return pressure** — 310 Bar [4500 PSI]. Do not exceed Δ pressure rating (see chart above).

Δ Bar [Δ PSI] — True pressure difference between inlet port and outlet port.

Continuous Rating — Motor may be run continuously at these ratings.

Intermittent Operation — 10% of every minute.

Recommended Fluids — Premium quality, anti-wear type hydraulic oil with a viscosity of not less than 70 SUS at operating temperature (see page 81).

Recommended Maximum System Operating Temp. — Is 82° C [180° F]

Recommended Filtration — per ISO Cleanliness Code, level 18/13

To assure best motor life, run motor for approximately one hour at 30% of rated pressure before application to full load. Be sure motor is filled with fluid prior to any load applications.

Dimensions — Two Speed Standard, Wheel, and Bearingless

Standard Rotation
Viewed from Shaft or Drive End
Port A Pressurized — CW
Port B Pressurized — CCW

Two Speed Standard Motor

Displ. cm ³ /r [in ³ /r]	80 [4.9]	100 [6.2]	130 [8.0]	160 [9.6]	195 [11.9]	245 [14.9]	305 [18.7]	395 [24.0]	490 [29.8]
Dim. X mm [inch]	137,4 [5.41]	142,0 [5.59]	148,5 [5.85]	148,5 [5.85]	155,2 [6.11]	164,2 [6.47]	175,7 [6.92]	191,5 [7.54]	209,0 [8.23]
Dim. Y mm [inch]	231,6 [9.12]	236,5 [9.31]	242,9 [9.56]	242,9 [9.56]	249,4 [9.82]	258,6 [10.18]	270,1 [10.63]	286,1 [11.26]	303,3 [11.94]

Two Speed Wheel Motor

Dim. X mm [inch]	97,2 [3.83]	101,8 [4.01]	108,3 [4.27]	108,3 [4.27]	115,0 [4.53]	124,2 [4.89]	135,5 [5.34]	151,4 [5.96]	168,9 [6.65]
Dim. Y mm [inch]	191,5 [7.54]	196,4 [7.73]	202,7 [7.98]	202,7 [7.98]	209,3 [8.24]	218,5 [8.60]	229,9 [9.05]	245,9 [9.68]	263,1 [10.36]

Two Speed Bearingless Motor

Dim. X mm [inch]	79,3 [3.13]	83,8 [3.30]	90,3 [3.56]	90,3 [3.56]	97,0 [3.82]	106,2 [4.18]	117,8 [4.64]	133,6 [5.26]	150,9 [5.94]
Dim. Y mm [inch]	174,0 [6.85]	178,9 [7.04]	185,2 [7.29]	185,2 [7.29]	191,8 [7.55]	201,0 [7.91]	212,4 [8.36]	228,4 [8.99]	245,6 [9.67]

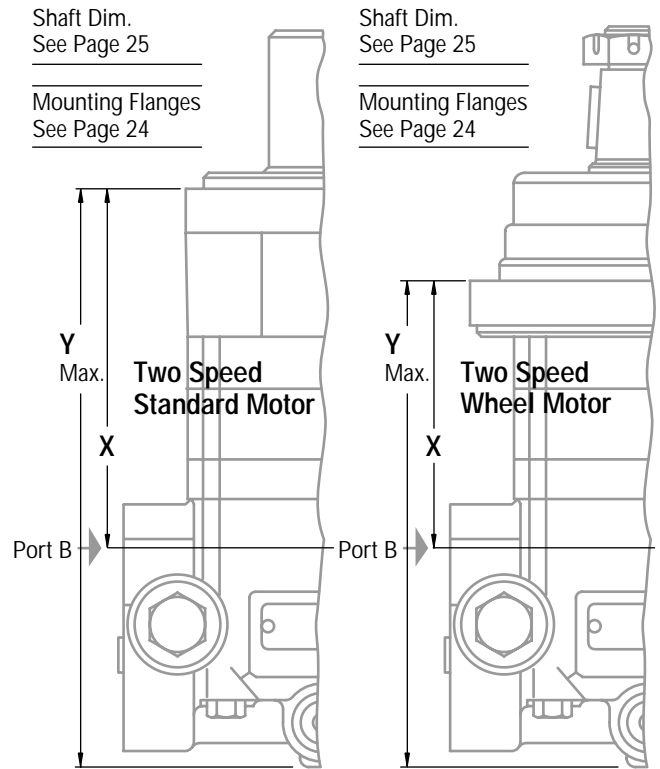

7/16-20 UNF-2B O-ring Port — Pilot Control
Pilot Port Pressurized 6,9 Δ Bar [100 Δ PSI]
High Speed Low Torque (HSLT)
Pilot Port Depressurized (Tank)
Low Speed High Torque (LSHT)

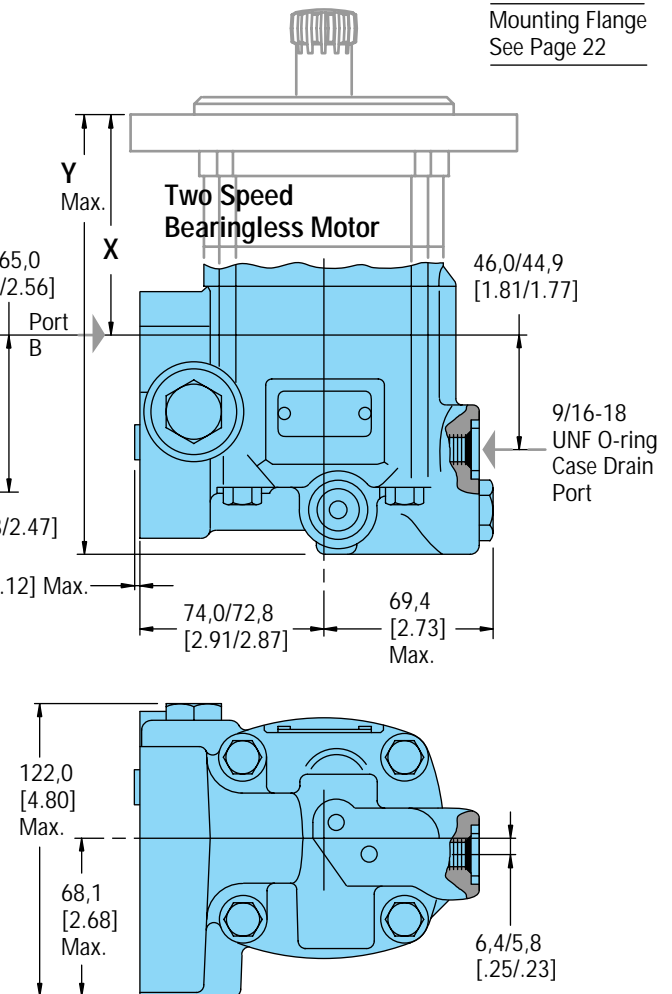
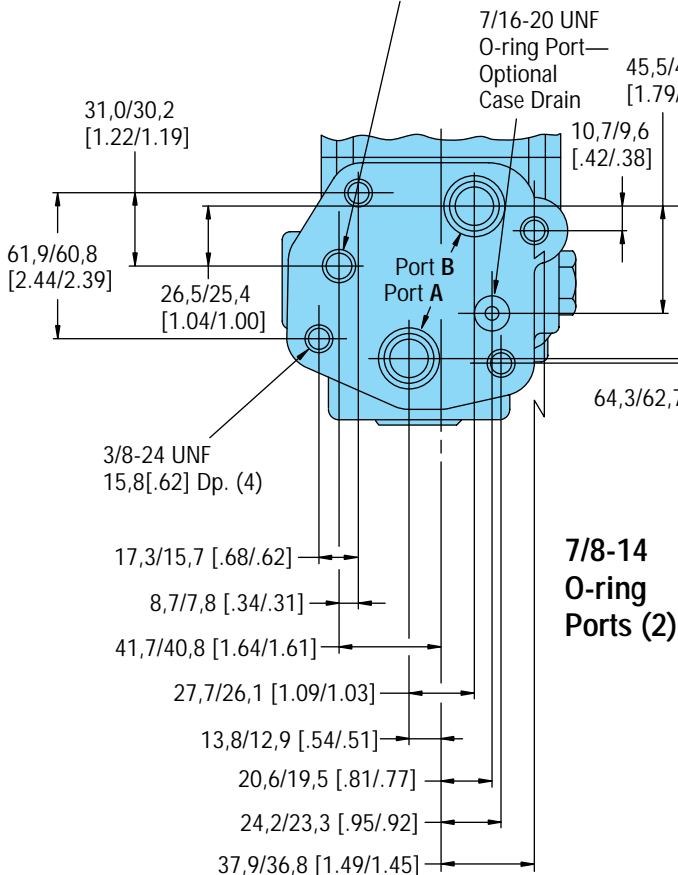

Product Numbers — Two Speed 2000 Series

Product Numbers—2000 Series Motors — Two Speed

Use digit prefix —**104-**, **105-**, or **106-** plus four digit number from charts for complete product number—Example **106-2007**.
Orders will not be accepted without three digit prefix.

Mounting	Shaft	Ports	Displ. cm ³ /r [in ³ /r] Product Number								
			80 [4.9]	100 [6.2]	130 [8.0]	160 [9.6]	195 [11.9]	245 [14.9]	305 [18.7]	395 [24.0]	490 [29.8]
2 Bolt SAE A Flange	1 inch Straight	7/8-14 O-ring Staggered	104 -2001	-2002	-2003	-2004	-2005	-2006	-2007	-2008	—
	1-1/4 Inch Straight	7/8-14 O-ring Staggered	104 -2009	-2010	-2011	-2012	-2013	-2014	-2015	-2016	—
	1-1/4 Inch 14 T Splined	7/8-14 O-ring Staggered	104 -2017	-2018	-2019	-2020	-2021	-2022	-2023	-2024	—
Wheel Motor	1-1/4 Inch Tapered	7/8-14 O-ring Staggered	105 -2001	-2002	-2003	-2004	-2005	-2006	-2007	-2008	—
	1-1/4 Inch 14 T Splined	7/8-14 O-ring Staggered	105 -2009	-2010	-2011	-2012	-2013	-2014	-2015	-2016	—
Bearingless		7/8-14 O-ring Staggered	106 -2001	-2002	-2003	-2004	-2005	-2006	-2007	-2008	—

106-2007

2000 Series Motors with a configuration *Not Shown* in the charts above: Contact your Eaton Representative.

Hayes M15WM Brake System 2000 Series Wheel Motors

Hayes Industrial Brakes, Inc. supplies its Model M15WM mechanical parking/service brake for use with 2000 Series wheel motors on commercial turf and specialty-vehicle applications. Basic packages available are:

- M15WM for 203,2 [8.0] wheels (152,4 [6.0] rotor diameter)
- M15WM for 254 [10.0] wheels (209,6 [8.25] rotor diameter)

Features

- Up to 1450 lb. of clamping force available
- Simple single-piece caliper bridge design
- Fewer moving parts
- Comprehensive braking system design includes:
 - Aluminum caliper
 - Ductile cast iron bracket
 - Ductile cast iron hub/disc
- Several shaft sizes and hub mounting hole options available.

Note: Brake systems must be purchased directly from Hayes Industrial Brake. Eaton does not sell the brake nor does it install on motors. For more information, contact:

Hayes Industrial Brake, Inc.
5800 West Donges Bay Road
Mequon, WI 57092
Phone: (262) 242-4300; Fax: (262) 242-0524

Dimensions — Mounting

8-Inch Wheel 305 N-m (2700 lb-in) Max. Torque

Requires special 2K mounting code "P".

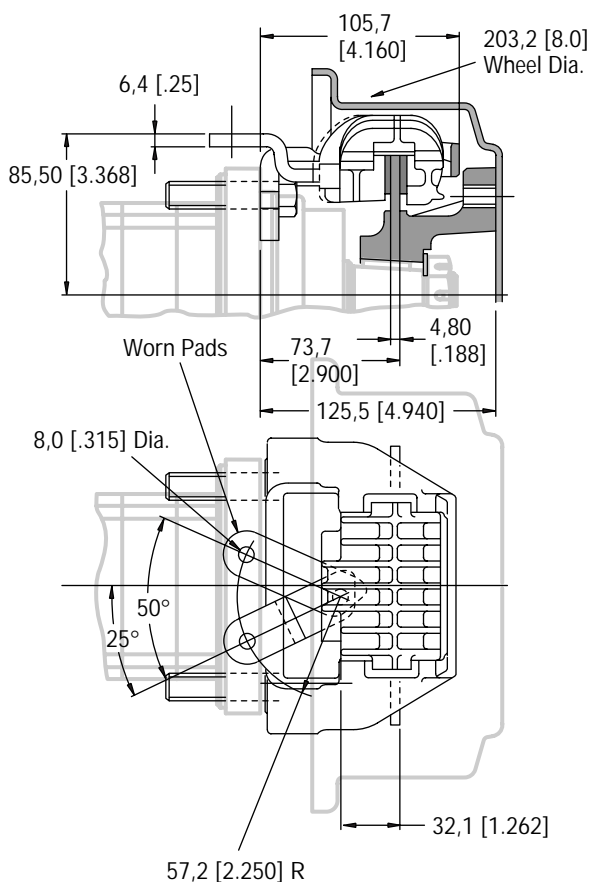

10-Inch Wheel 429,4 N-m (3800 lb-in) Max. Torque

Compatible with standard 4-bolt wheel configuration

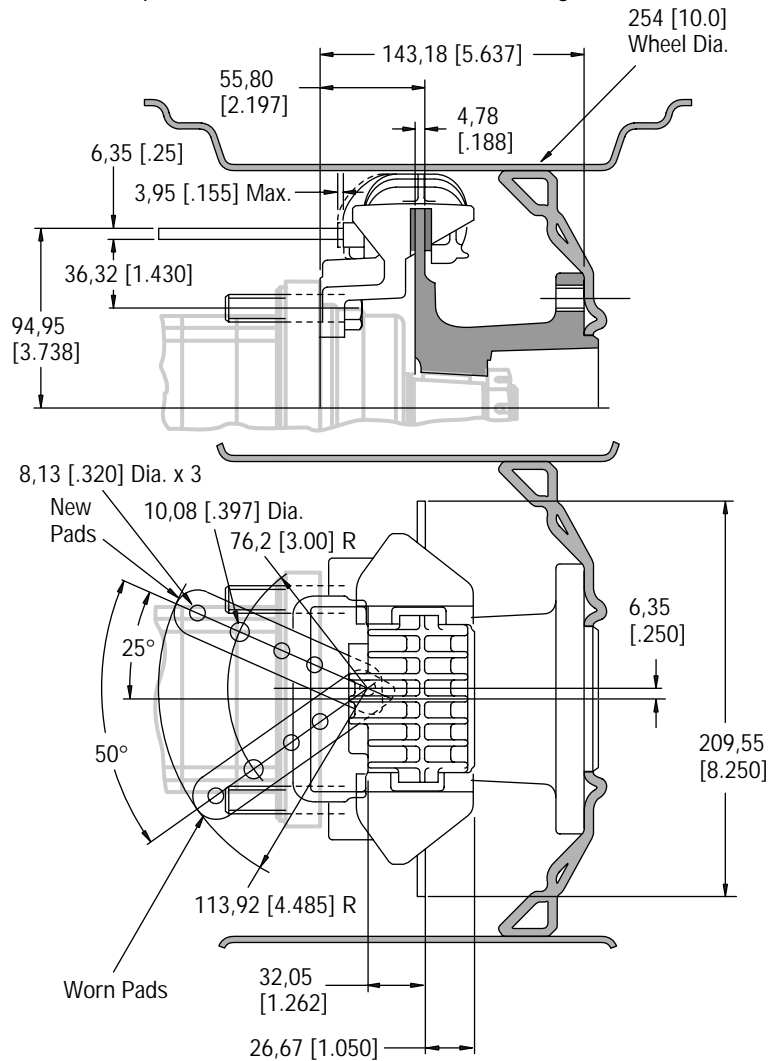

Specifications

4000 Series

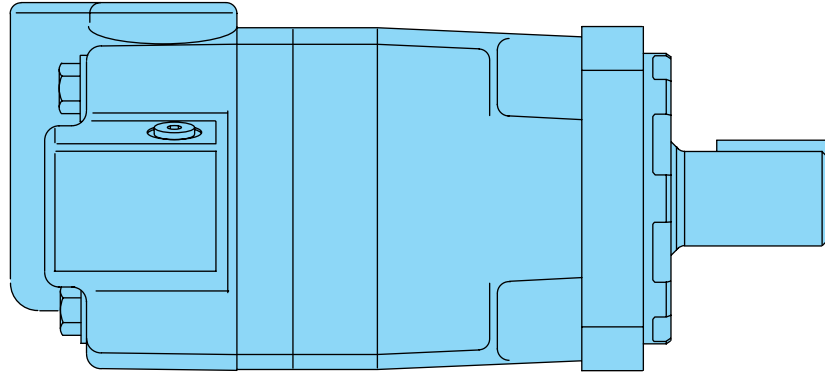

Specification Data—4000 Series

		110	130	160	205	245	310	395	495	625	
Displ. cm ³ /r	[in ³ /r]	110 [6.7]	130 [7.9]	160 [9.9]	205 [12.5]	245 [15.0]	310 [19.0]	395 [24.0]	495 [30.0]	625 [38.0]	
Max. Speed (RPM) @ Flow	Continuous	697	722	582	459	383	303	239	191	151	
	Intermittent	868	862	693	546	532	422	376	305	241	
Flow LPM [GPM]	Continuous	75 [20]	95 [25]	95 [25]	95 [25]	95 [25]	95 [25]	95 [25]	95 [25]	95 [25]	
	Intermittent	95 [25]	115 [30]	115 [30]	115 [30]	130 [35]	130 [35]	150 [40]	150 [40]	150 [40]	
Torque Nm [lb-in]	★ 1-5/8 Inch Dia. Tapered Shaft	Continuous	320 [2850]	375 [3330]	485 [4290]	600 [5300]	705 [6240]	850 [7530]	930 [8240]	945 [8375]	970 [8605]
		Intermittent	470 [4160]	560 [4940]	705 [6240]	800 [7100]	845 [7470]	1065 [9420]	1185 [10470]	1170 [10350]	1180 [10450]
Pressure Δ Bar [Δ PSI]	★ 1-5/8 Inch Dia. Tapered Shaft	Continuous	205 [3000]	205 [3000]	205 [3000]	205 [3000]	205 [3000]	205 [3000]	190 [2750]	140 [2000]	115 [1700]
		Intermittent	310 [4500]	310 [4500]	310 [4500]	310 [4500]	260 [3750]	260 [3750]	240 [3500]	170 [2500]	140 [2000]
		Peak	310 [4500]	310 [4500]	310 [4500]	310 [4500]	310 [4500]	310 [4500]	295 [4250]	230 [3300]	180 [2600]

Maximum Case Pressure - without Case Drain * — 100 Bar [1500 PSI]

A simultaneous maximum torque and maximum speed NOT recommended. For permissible continuous and intermittent operating combinations of pressure and flow refer to performance data on pages 38 - 41.

★ **Maximum torque for 1-1/4 inch shaft** — 770 Nm [6800 lb-in] Continuous and 960 Nm [8500 lb-in] intermittent.

* For back pressure over 105 Bar [1500 PSI] use an external case drain. Install case drain lines so that the motor case remains filled at all times.

Maximum inlet pressure — 310 Bar [4500 PSI]. Do not exceed Δ pressure rating (see chart above).

* **Maximum return pressure** — 310 Bar [4500 PSI]. Do not exceed Δ pressure rating (see chart above).

Δ Bar [Δ PSI] — True pressure difference between inlet port and outlet port.

Continuous Rating — Motor may be run continuously at these ratings.

Intermittent Operation — 10% of every minute.

Peak Operation — 1% of every minute.

Recommended Fluids — Premium quality, anti-wear type hydraulic oil with a viscosity of not less than 70 SUS at operating temperature (see page 81).

Recommended Maximum System Operating Temp. — Is 82° C [180° F]

Recommended Filtration — per ISO Cleanliness Code, level 18/13

To assure best motor life, run motor for approximately one hour at 30% of rated pressure before application to full load. Be sure motor is filled with fluid prior to any load applications.

Performance

Data 4000 Series

110 cm³/r [6.7 in³/r]
Δ Pressure Bar [PSI]

	[250] 15	[500] 35	[1000] 70	[1500] 105	[2000] 140	[2500] 170	[3000] 205	[3500] 240	[4000] 275	[4500] 310
[.5]	[150] 15	[390] 45	[850] 95	[1290] 145						
1.9	14	10	5	2						
[1]	[170] 20	[440] 50	[900] 100	[1380] 155	[1860] 210	[2270] 255	[2680] 305	[3110] 350		
3.8	34	33	31	28	25	22	18	11		
[2]	[180] 20	[450] 50	[910] 105	[1390] 155	[1860] 210	[2280] 260	[2700] 305	[3120] 355	[3450] 390	
7.5	68	67	62	56	50	44	36	28	18	
[4]	[190] 20	[460] 50	[940] 105	[1400] 160	[1870] 210	[2310] 260	[2730] 310	[3140] 355	[3560] 400	[3880] 440
15	138	136	123	110	97	84	70	56	42	28
[6]	[200] 25	[470] 55	[960] 110	[1420] 160	[1880] 210	[2320] 260	[2760] 310	[3200] 360	[3640] 410	[3950] 455
23	207	204	200	193	184	174	163	150	136	121
[8]	[190] 20	[460] 50	[950] 105	[1420] 160	[1880] 210	[2340] 265	[2790] 315	[3230] 365	[3670] 415	[4010] 455
30	277	274	270	262	253	241	228	213	196	179
[10]	[180] 20	[450] 50	[950] 105	[1420] 160	[1890] 215	[2350] 265	[2820] 320	[3260] 370	[3700] 420	[4070] 460
38	347	344	340	331	322	308	292	274	255	236
[12]	[160] 20	[450] 50	[940] 105	[1420] 160	[1880] 210	[2350] 265	[2820] 320	[3260] 370	[3710] 420	[4080] 460
45	417	414	410	400	390	374	355	335	313	292
[14]	[140] 15	[440] 50	[930] 105	[1420] 160	[1880] 210	[2350] 265	[2830] 320	[3280] 370	[3730] 420	[4110] 465
53	487	484	480	469	458	440	419	406	388	368
[16]	[130] 15	[440] 50	[920] 105	[1410] 160	[1870] 210	[2350] 265	[2840] 320	[3300] 375	[3750] 425	[4120] 465
61	556	553	549	537	525	505	482	455	428	404
[18]	[100] 10	[440] 50	[910] 105	[1400] 160	[1870] 210	[2350] 265	[2840] 320	[3300] 375	[3770] 425	[4140] 465
68	626	622	618	606	593	570	545	516	485	460
[20]	[80] 10	[430] 50	[900] 105	[1370] 155	[1860] 210	[2350] 265	[2850] 320	[3320] 375	[3790] 430	[4160] 470
76	697	694	690	677	664	638	611	579	545	518
[25]	[400] 45	[860] 95	[1350] 155	[1850] 210	[2320] 260	[2830] 320	[3300] 375	[3780] 425		
95	868	861	838	816	792	767	729	690		

130 cm³/r [7.9 in³/r]
Δ Pressure Bar [PSI]

	[250] 15	[500] 35	[1000] 70	[1500] 105	[2000] 140	[2500] 170	[3000] 205	[3500] 240	[4000] 275	[4500] 310
[.5]	[310] 35	[510] 60	[1060] 120	[1590] 180						
1.9	32	28	25	2						
[1]	[290] 30	[530] 60	[1080] 120	[1600] 180	[2110] 240	[2640] 300	[3060] 345	[3450] 390		
3.8	30	28	25	19	14	13	12	4		
[2]	[280] 30	[530] 60	[1100] 125	[1620] 185	[2140] 240	[2660] 300	[3180] 360	[3600] 405	[4020] 455	[4080] 460
7.5	57	56	53	47	42	40	38	29	20	12
[4]	[260] 30	[520] 60	[1100] 125	[1650] 185	[2200] 250	[2700] 305	[3210] 365	[3660] 415	[4060] 460	[4560] 515
15	116	114	111	105	100	95	90	70	50	37
[6]	[240] 25	[510] 60	[1100] 125	[1650] 185	[2200] 250	[2720] 305	[3240] 365	[3710] 420	[4180] 470	[4660] 525
23	173	170	167	161	156	149	142	123	104	91
[8]	[230] 25	[510] 60	[1080] 120	[1640] 185	[2210] 250	[2740] 310	[3270] 370	[3770] 425	[4270] 480	[4750] 535
30	228	225	222	216	210	202	194	176	158	145
[10]	[210] 25	[510] 60	[1080] 120	[1640] 185	[2210] 250	[2750] 310	[3300] 375	[3840] 430	[4350] 490	[4840] 545
38	283	281	278	272	266	256	246	229	212	189
[12]	[200] 25	[500] 55	[1070] 120	[1640] 185	[2200] 250	[2750] 310	[3300] 375	[3840] 430	[4370] 495	[4870] 550
45	341	338	335	329	323	312	300	282	263	237
[14]	[180] 20	[490] 55	[1060] 120	[1640] 185	[2220] 250	[2750] 310	[3310] 375	[3860] 435	[4390] 495	[4890] 550
53	400	396	392	386	380	368	355	335	315	286
[16]	[160] 20	[490] 55	[1050] 120	[1630] 185	[2220] 250	[2760] 310	[3310] 375	[3860] 435	[4400] 495	[4920] 555
61	457	453	449	443	437	424	410	388	366	335
[18]	[130] 15	[480] 55	[1050] 120	[1630] 185	[2220] 250	[2760] 310	[3320] 375	[3870] 435	[4420] 495	[4940] 560
68	516	511	506	500	494	480	465	442	418	384
[20]	[110] 10	[470] 55	[1040] 120	[1620] 185	[2210] 250	[2760] 310	[3330] 375	[3890] 440	[4440] 500	
76	574	569	564	559	551	536	520	495	470	
[22]	[70] 10	[450] 50	[1020] 115	[1610] 180	[2190] 245	[2750] 310	[3320] 375	[3880] 440	[4440] 500	
83	633	628	624	615	606	590	573	547	520	
[25]	[50] 5	[430] 50	[1000] 115	[1580] 180	[2160] 245	[2720] 305	[3300] 375	[3860] 435	[4430] 500	
95	722	718	714	702	690	672	653	625	595	
[30]	[400] 45	[940] 105	[1500] 170	[2080] 235	[2670] 300	[3200] 360	[3740] 425			
114	862	855	842	827	806	783	749			

Motors run with high efficiency in all areas designated with a number for torque and speed, however for best motor life select a motor to run with a torque and speed range shown in the light blue area.

[3780]
425 } Torque [lb-in]
Nm
690 } Speed RPM

Performance data is typical at 120 SUS. Actual data may vary slightly from unit to unit in production

160 cm³/r [9.9 in³/r]
Δ Pressure Bar [PSI]

	[250] 15	[500] 35	[1000] 70	[1500] 105	[2000] 140	[2500] 170	[3000] 205	[3500] 240	[4000] 275	[4500] 310
[.5]	[300] 35	[680] 75	[1320] 150	[2050] 230	[2750] 310					
1.9	8	7	5	3	1					
[1]	[320] 35	[700] 80	[1350] 155	[2070] 235	[2780] 315	[3300] 375	[3940] 445	[4410] 500	[4950] 560	
3.8	23	22	20	19	18	16	15	8	2	
[2]	[330] 35	[700] 80	[1360] 155	[2080] 235	[2790] 315	[3340] 375	[3970] 450	[4530] 510	[5090] 575	[5590] 630
7.5	46	45	41	40	37	32	29	27	25	13
[4]	[320] 35	[710] 80	[1400] 160	[2100] 240	[2820] 320	[3420] 385	[4020] 455	[4620] 520	[5220] 590	[5730] 645
15	93	92	90	88	84	76	73	62	51	35
[6]	[300] 35	[710] 80	[1420] 160	[2140] 240	[2850] 320	[3510] 395	[4180] 470	[4760] 540	[5340] 605	[5870] 660
23	137	135	134	131	126	120	114	90	75	57
[8]	[280] 30	[720] 80	[1450] 165	[2180] 245	[2900] 330	[3560] 400	[4230] 480	[4850] 550	[5470] 620	[6010] 680
30	184	182	180	176	171	163	154	138	122	100
[10]	[260] 30	[720] 80	[1480] 165	[2220] 250	[2950] 335	[3610] 410	[4290] 485	[4920] 560	[5560] 630	[6160] 695
38	232	229	226	221	216	206	194	182	169	142
[12]	[240] 25	[700] 80	[1450] 165	[2190] 245	[2920] 330	[3590] 405	[4280] 485	[4920] 560	[5570] 630	[6180] 700
45	277	274	272	266	260	250	238	224	209	182
[14]	[220] 25	[680] 75	[1420] 160	[2160] 245	[2890] 325	[3570] 405	[4270] 480	[4920] 555	[5580] 630	[6200] 700
53	321	319	318	311	304	294	282	266	249	222
[16]	[200] 25	[670] 75	[1400] 160	[2130] 240	[2860] 325	[3550] 400	[4260] 480	[4900] 555	[5550] 630	[6220] 705
61	366	364	362	356	348	338	326	308	289	262
[18]	[180] 20	[650] 75	[1360] 155	[2100] 240	[2830] 320	[3530] 405	[4250] 480	[4910] 555	[5600] 635	[6240] 705
68	410	409	407	401	392	382	370	350	329	302
[20]	[150] 15	[630] 70	[1340] 150	[2070] 235	[2800] 315	[3510] 395	[4240] 480	[4910] 555	[5610] 635	
76	460	458	456	448	440	429	417	396	373	
[22]	[120] 15	[620] 70	[1330] 150	[2060] 235	[2790] 315	[3500] 395	[4220] 475	[4910] 555	[5600] 635	
83	509	506	502	494	484	473	461	438	413	
[25]	[70] 10	[600] 70	[1320] 150	[2050] 230	[2780] 315	[3480] 395	[4210] 475	[4900] 555	[5590] 630	
95	582	578	573	563	552	540	526	501	474	
[30]	[560] 65	[1280] 145	[1990] 225	[2700] 305	[3430] 390	[3970] 450	[4640] 525			
114	693	687	675	661	647	630	600			

Continuous

245 cm³/r [15.0 in³/r]
 Δ Pressure Bar [PSI]

Performance Data 4000 Series

	[250] 15	[500] 35	[750] 50	[1000] 70	[1250] 85	[1500] 105	[1750] 120	[2000] 140	[2250] 155	[2500] 170	[2750] 190	[3000] 205	[3250] 225	[3500] 240	[3750] 260	
[.5] 1.9	[460] 50 5	[980] 110 2														
[1] 3.8	[480] 55 14	[990] 110 14	[1490] 170 14	[1990] 225 13	[2480] 280 13	[2970] 335 12	[3400] 385 12	[3830] 435 11	[4250] 480 11	[4680] 530 10	[5020] 565 4					
[2] 7.5	[500] 55 30	[1000] 115 30	[1520] 170 29	[2040] 230 29	[2540] 285 28	[3050] 345 27	[3420] 385 26	[3930] 445 24	[4440] 500 23	[4900] 555 22	[5320] 600 20	[5740] 650 18	[6160] 695 16	[6640] 750 14	[7150] 810 11	
[4] 15	[510] 60 61	[1030] 115 61	[1560] 175 60	[2080] 235 65	[2600] 295 59	[3130] 355 59	[3630] 415 58	[4130] 465 56	[4630] 525 53	[5120] 580 49	[5570] 630 47	[6030] 680 44	[6480] 730 42	[6870] 775 39	[7340] 830 36	
[6] 23	[510] 60 91	[1040] 120 90	[1570] 175 90	[2100] 235 89	[2620] 295 88	[3160] 355 85	[3660] 415 86	[4200] 475 83	[4710] 530 80	[5220] 590 75	[5690] 645 72	[6150] 695 70	[6620] 750 67	[7050] 795 63	[7430] 840 59	
[8] 30	[500] 55 121	[1020] 115 121	[1560] 175 120	[2110] 240 119	[2630] 295 118	[3150] 355 117	[3680] 415 115	[4210] 475 113	[4740] 535 111	[5250] 595 106	[5720] 645 103	[6200] 700 99	[6670] 755 96	[7090] 800 91	[7470] 845 87	
[10] 38	[470] 55 152	[1000] 115 151	[1540] 175 150	[2100] 235 148	[2620] 295 148	[3150] 355 145	[3690] 415 143	[4230] 480 141	[4770] 540 137	[5290] 600 133	[5760] 650 129	[6240] 705 125	[6710] 760 125	[7140] 805 120		
[12] 45	[450] 50 183	[980] 110 182	[1530] 175 180	[2080] 235 179	[2610] 295 178	[3140] 355 176	[3680] 415 173	[4220] 475 170	[4760] 540 166	[5280] 595 161	[5750] 650 157	[6230] 705 157	[6700] 755 152			
[14] 53	[420] 45 213	[960] 110 212	[1520] 170 211	[2060] 235 210	[2600] 295 209	[3130] 355 208	[3670] 415 206	[4200] 475 203	[4740] 535 200	[5260] 595 195	[5740] 650 190	[6220] 705 185				
[16] 61	[400] 45 244	[950] 105 243	[2040] 170 242	[2580] 230 240	[3120] 290 239	[3660] 355 236	[4190] 415 232	[4730] 475 229	[5250] 535 225	[5730] 595 219	[6210] 700 213					
[18] 68	[380] 45 275	[930] 105 274	[1480] 165 273	[2020] 230 272	[2560] 290 270	[3110] 350 269	[3650] 415 266	[4180] 470 262	[4710] 530 259	[5230] 590 254	[5720] 645 248	[6200] 700 241				
[20] 76	[350] 40 305	[910] 105 305	[1460] 165 304	[2000] 225 303	[2550] 290 302	[3100] 350 300	[3640] 410 296	[4170] 470 292	[4700] 530 288	[5220] 590 283	[5710] 645 276					
[22] 83	[310] 35 337	[870] 100 336	[1420] 160 335	[1970] 225 334	[2500] 280 332	[3050] 345 330	[3590] 405 326	[4140] 465 323	[4680] 530 319	[5200] 590 313	[5680] 640 306					
[25] 95	[260] 30 383	[820] 95 382	[1380] 155 381	[1930] 220 380	[2460] 280 378	[2980] 335 376	[3540] 400 372	[4090] 460 369	[4640] 525 365	[5180] 585 357						
[30] 114		[680] 75 457	[1250] 140 456	[1860] 210 455	[2390] 270 453	[2900] 330 450	[3430] 390 445	[3960] 445 442	[4460] 505 437	[4950] 560 427						
[35] 132			[1110] 125 532	[1740] 195 531	[2270] 255 528	[2790] 315 525	[3340] 375 519	[3910] 440 515	[4400] 495 509							

Motors run with high efficiency in all areas designated with a number for torque and speed, however for best motor life select a motor to run with a torque and speed range shown in the light blue area.

[1110]
125 } Torque [lb-in]
532 } Nm
Speed RPM

Continuous
Intermittent

310 cm³/r [19.0 in³/r]
 Δ Pressure Bar [PSI]

	[250] 15	[500] 35	[750] 50	[1000] 70	[1250] 85	[1500] 105	[1750] 120	[2000] 140	[2250] 155	[2500] 170	[2750] 190	[3000] 205	[3250] 225	[3500] 240	[3750] 260	
[.5] 1.9	[600] 70 4	[1150] 130 2														
[1] 3.8	[620] 70 11	[1270] 145 11	[1920] 215 11	[2560] 290 10	[3170] 360 10	[3780] 425 10	[4290] 485 9	[4900] 555 9	[5490] 620 9	[6080] 685 8	[6670] 755 8	[7270] 820 7	[7880] 890 7	[8490] 960 6	[9080] 1025 5	
[2] 7.5	[630] 70 23	[1280] 145 23	[1940] 220 22	[2590] 295 22	[3230] 365 21	[3830] 435 21	[4450] 505 20	[5070] 575 20	[5680] 640 19	[6300] 710 18	[6910] 780 18	[7530] 850 17	[8160] 920 17	[8790] 995 16	[9420] 1065 15	
[4] 15	[640] 70 47	[1290] 145 47	[1960] 220 46	[2640] 300 46	[3290] 370 45	[3940] 445 45	[4600] 520 44	[5240] 590 44	[5880] 665 43	[6510] 735 42	[7150] 800 42	[7790] 880 41	[8450] 955 41	[9100] 1030 40		
[6] 23	[650] 75 71	[1300] 145 71	[1970] 225 70	[2660] 300 70	[3320] 375 69	[4000] 450 69	[4680] 530 68	[5330] 600 67	[5980] 675 66	[6630] 750 64	[7280] 825 64	[7940] 895 63				
[8] 30	[640] 70 96	[1300] 145 96	[1980] 225 95	[2670] 300 95	[3350] 380 94	[4030] 455 94	[4710] 530 93	[5360] 605 92	[6020] 680 91	[6670] 755 89	[7320] 825 88					
[10] 38	[620] 70 121	[1280] 145 120	[1970] 225 120	[2660] 300 119	[3340] 375 119	[4070] 460 118	[4740] 535 117	[5390] 610 116	[6050] 685 115	[6710] 760 112	[7370] 835 109					
[12] 45	[600] 70 145	[1260] 140 144	[1940] 220 144	[2630] 295 143	[3340] 375 142	[4040] 455 142	[4730] 535 141	[5390] 610 140	[6060] 685 139	[6720] 760 135						
[14] 53	[570] 65 169	[1240] 140 169	[1920] 215 168	[2600] 295 168	[3310] 375 167	[4000] 450 167	[4710] 530 165	[5380] 610 164	[6060] 685 163	[6730] 760 159						
[16] 61	[540] 60 193	[1230] 140 193	[1900] 215 192	[2580] 290 192	[3280] 370 190	[3970] 450 189	[4700] 530 188	[5380] 610 187	[6050] 685 185							
[18] 68	[490] 55 217	[1210] 135 217	[1880] 210 216	[2550] 290 216	[3240] 365 214	[3930] 445 213	[4680] 530 211	[5370] 605 209	[6040] 680 207							
[20] 76	[450] 50 242	[1190] 135 242	[1860] 210 242	[2520] 285 241	[3210] 365 240	[3900] 440 238	[4670] 530 236	[5360] 605 234	[6030] 680 232							
[22] 83	[420] 45 267	[1130] 130 266	[1820] 205 266	[2520] 285 265	[3180] 360 264	[3870] 440 262	[4640] 525 260	[5320] 600 258								
[25] 95	[340] 40 303	[1050] 120 302	[1780] 200 302	[2510] 285 301	[3160] 355 300	[3820] 430 299	[4590] 520 296	[5280] 595 293								
[30] 114		[1010] 115 363	[1700] 190 362	[2420] 275 360	[3100] 350 359	[3720] 420 358	[4500] 510 354	[5140] 580 351								
[35] 132			[1580] 180 422	[2360] 265 420	[2950] 335 419	[3540] 400 418	[4390] 495 413									

Performance data is typical at 120 SUS. Actual data may vary slightly from unit to unit in production

395 cm³/r [24.0 in³/r]
 Δ Pressure Bar [PSI]

Performance Data 4000 Series

	[250] 15	[500] 35	[750] 50	[1000] 70	[1250] 85	[1500] 105	[1750] 120	[2000] 140	[2250] 155	[2500] 170	[2750] 190	[3000] 205	[3250] 225	[3500] 240
[.5] 1.9	[700] 80 4	[1340] 150 2												
[1] 3.8	[750] 85 9	[1430] 160 9	[2110] 240 8	[2770] 315 8	[3460] 390 8	[4170] 470 7	[4890] 550 7	[5610] 635 7	[6310] 715 5	[7010] 790 4	[7700] 870 2			
[2] 7.5	[800] 90 18	[1500] 170 18	[2290] 260 17	[3030] 340 16	[3850] 435 16	[4620] 520 15	[5310] 600 15	[6000] 680 14	[6750] 765 13	[7490] 845 13	[8240] 930 12	[8990] 1015 11	[9730] 1100 10	[10470] 1185 8
[4] 15	[860] 95 38	[1630] 185 38	[2470] 280 37	[3310] 375 36	[4120] 465 36	[4900] 555 35	[5640] 635 35	[6390] 720 34	[7190] 810 34	[7890] 890 33	[8780] 990 32			
[6] 23	[860] 95 57	[1690] 190 57	[2540] 285 55	[3410] 385 55	[4180] 470 54	[4980] 565 53	[5780] 655 52	[6580] 745 50	[7400] 835 49	[8220] 930 47				
[8] 30	[840] 95 76	[1680] 190 76	[2550] 290 75	[3400] 385 74	[4260] 480 73	[5090] 575 72	[5870] 665 70	[6650] 750 68	[7480] 845 66					
[10] 38	[800] 90 95	[1680] 190 95	[2550] 290 94	[3400] 385 93	[4260] 480 92	[5100] 575 91	[5920] 670 89	[6730] 760 86	[7560] 855 84					
[12] 45	[760] 85 114	[1660] 190 114	[2520] 285 113	[3380] 380 112	[4270] 480 111	[5110] 575 110	[5900] 665 108	[6690] 755 105						
[14] 53	[740] 85 133	[1640] 185 133	[2490] 280 132	[3370] 380 131	[4260] 480 130	[5100] 575 129	[5880] 665 127	[6650] 750 124						
[16] 61	[710] 80 153	[1620] 185 153	[2460] 280 152	[3350] 380 151	[4240] 480 149	[5080] 575 147	[5840] 660 145							
[18] 68	[680] 75 172	[1600] 180 172	[2430] 275 171	[3340] 375 170	[4220] 475 168	[5060] 570 166	[5810] 655 164							
[20] 76	[610] 70 192	[1580] 180 191	[2400] 270 190	[3320] 375 189	[4210] 475 187	[5040] 570 185	[5780] 655 183							
[22] 83	[570] 65 211	[1490] 170 210	[2340] 265 209	[3220] 365 208	[4160] 470 206	[5010] 565 204	[5740] 650 201							
[25] 95	[490] 55 239	[1350] 155 238	[2250] 255 237	[3080] 350 236	[4070] 460 235	[4960] 560 233	[5700] 645 230							
[30] 114		[1080] 120 285	[1650] 185 284	[2270] 255 282	[3020] 340 281	[3850] 435 279								
[35] 132			[1520] 170 331	[2120] 240 330	[2870] 325 328	[3760] 425 325								
[40] 151				[2050] 230 376	[2790] 315 374	[3620] 410 371								

Motors run with high efficiency in all areas designated with a number for torque and speed, however for best motor life select a motor to run with a torque and speed range shown in the light blue area.

[2050]
230
376 } Torque [lb-in]
 } Nm
 } Speed RPM

Continuous
Intermittent

495 cm³/r [30.0 in³/r]
 Δ Pressure Bar [PSI]

	[250] 15	[500] 35	[750] 50	[1000] 70	[1250] 85	[1500] 105	[1750] 120	[2000] 140	[2250] 155	[2500] 170
[.5] 1.9	[800] 90 3	[1750] 200 1								
[1] 3.8	[880] 100 7	[1875] 210 6	[2875] 325 6	[3825] 430 5	[4775] 540 4	[5720] 645 3	[6670] 755 2	[7600] 860 1		
[2] 7.5	[905] 100 18	[1940] 220 17	[2975] 335 17	[3990] 450 16	[5010] 565 15	[6010] 680 12	[7010] 790 11	[8000] 905 10	[8980] 1015 8	
[4] 15	[935] 105 30	[2005] 225 29	[3075] 345 28	[4160] 470 27	[5245] 595 26	[6300] 710 23	[7355] 830 21	[8375] 945 19	[9400] 1060 17	[10350] 1170 14
[6] 23	[920] 105 45	[2010] 225 44	[3100] 350 43	[4185] 475 42	[5265] 595 40	[6345] 715 37	[7420] 840 35	[8445] 955 32	[9465] 1070 30	
[8] 30	[905] 100 61	[2015] 230 60	[3125] 355 59	[4205] 475 57	[5295] 600 55	[6385] 720 52	[7485] 845 49	[8510] 960 46		
[10] 38	[880] 100 76	[1995] 225 75	[3095] 350 74	[4205] 475 72	[5295] 600 70	[6390] 720 66	[7480] 845 63	[8525] 960 59		
[12] 45	[860] 95 91	[1975] 225 90	[3095] 350 89	[4200] 475 87	[5305] 600 85	[6390] 720 81	[7475] 845 77			
[14] 53	[830] 95 106	[1945] 220 105	[3055] 345 104	[4165] 470 102	[5275] 595 100	[6360] 720 96	[7445] 840 92			
[16] 61	[805] 90 122	[1910] 215 120	[3020] 340 119	[4130] 465 117	[5245] 595 115	[6330] 715 111	[7420] 840 107			
[18] 68	[740] 85 137	[1860] 210 136	[2980] 335 134	[4105] 465 132	[5235] 590 130	[6305] 715 125	[7380] 835 121			
[20] 76	[680] 75 153	[1810] 205 152	[2940] 330 150	[4085] 460 147	[5225] 590 145	[6285] 710 140				
[25] 95	[570] 65 191	[1665] 190 189	[2800] 315 187	[4005] 455 184	[5210] 590 182	[6135] 695 177				
[30] 114		[1520] 170 228	[2645] 300 226	[3765] 425 223	[4885] 550 220	[5985] 675 215				
[35] 132			[2400] 270 265	[3510] 395 263						
[40] 151			[2155] 245 305	[3260] 370 303						

Performance data is typical at 120 SUS. Actual data may vary slightly from unit to unit in production

Performance Data 4000 Series

625 cm³/r [38.0 in³/r]
Δ Pressure Bar [PSI]

	[250] 15	[500] 35	[750] 50	[1000] 70	[1250] 85	[1500] 105	[1600] 100	[1700] 115	[1800] 125	[2000] 140
[.5] 1.9	[1000] 115 2									
[1] 3.8	[1080] 120 5	[2340] 265 5	[3600] 405 5	[4850] 550 4	[6100] 690 4	[7350] 830 3	[7820] 885 3	[8290] 935 2	[8760] 990 2	
[2] 7.5	[1085] 125 14	[2380] 270 14	[3675] 415 14	[5010] 565 13	[6350] 715 12	[7625] 860 11	[8115] 915 10	[8605] 970 9	[9095] 1030 8	[10075] 1140 7
[4] 15	[1090] 125 23	[2420] 275 23	[3750] 425 23	[5175] 585 22	[6600] 745 21	[7900] 895 19	[8410] 950 18	[9000] 1015 17	[9590] 1085 16	[10450] 1180 14
[6] 23	[1095] 125 35	[2460] 280 35	[3825] 430 35	[5220] 590 34	[6620] 750 33	[7950] 900 31	[8430] 950 30	[8910] 1005 29	[9490] 1070 28	
[8] 30	[1100] 125 48	[2500] 280 48	[3900] 440 47	[5270] 595 46	[6640] 750 45	[7990] 905 43	[8460] 955 43	[8925] 1010 42		
[10] 38	[1130] 130 60	[2550] 290 60	[3975] 450 59	[5320] 600 58	[6670] 755 57	[8045] 910 54	[8595] 970 53	[9150] 1035 52		
[12] 45	[1160] 130 72	[2600] 295 72	[4050] 460 71	[5375] 605 70	[6700] 755 69	[8100] 915 65	[8660] 980 64			
[14] 53	[1105] 125 84	[2535] 285 84	[3965] 450 83	[5325] 600 82	[6685] 755 81	[8065] 910 77	[8620] 975 76			
[16] 61	[1050] 120 96	[2465] 280 95	[3880] 440 95	[5275] 595 94	[6670] 755 93	[8035] 910 89	[8580] 970 88			
[18] 68	[990] 110 108	[2405] 270 107	[3825] 430 107	[5240] 590 105	[6655] 750 104	[7345] 830 100				
[20] 76	[930] 105 121	[2350] 265 120	[3770] 425 120	[5205] 590 118	[6640] 750 116					
[25] 95	[750] 85 151	[2175] 245 150	[3600] 405 149	[5000] 565 147	[6400] 725 146					
[30] 114	[550] 60 181	[1975] 225 180	[3400] 385 179	[4800] 530 177	[6200] 700 176					
[35] 132			[3125] 355 210	[4545] 515 208						
[40] 151			[2850] 320 241	[4295] 485 239						

Motors run with high efficiency in all areas designated with a number for torque and speed, however for best motor life select a motor to run with a torque and speed range shown in the light blue area.

[2850]
320
241 } Torque [lb-in]
Nm
Speed RPM

Continuous
Intermittent

Performance data is typical at 120 SUS. Actual data may vary slightly from unit to unit in production

Dimensions — 4000 Series Standard Motor

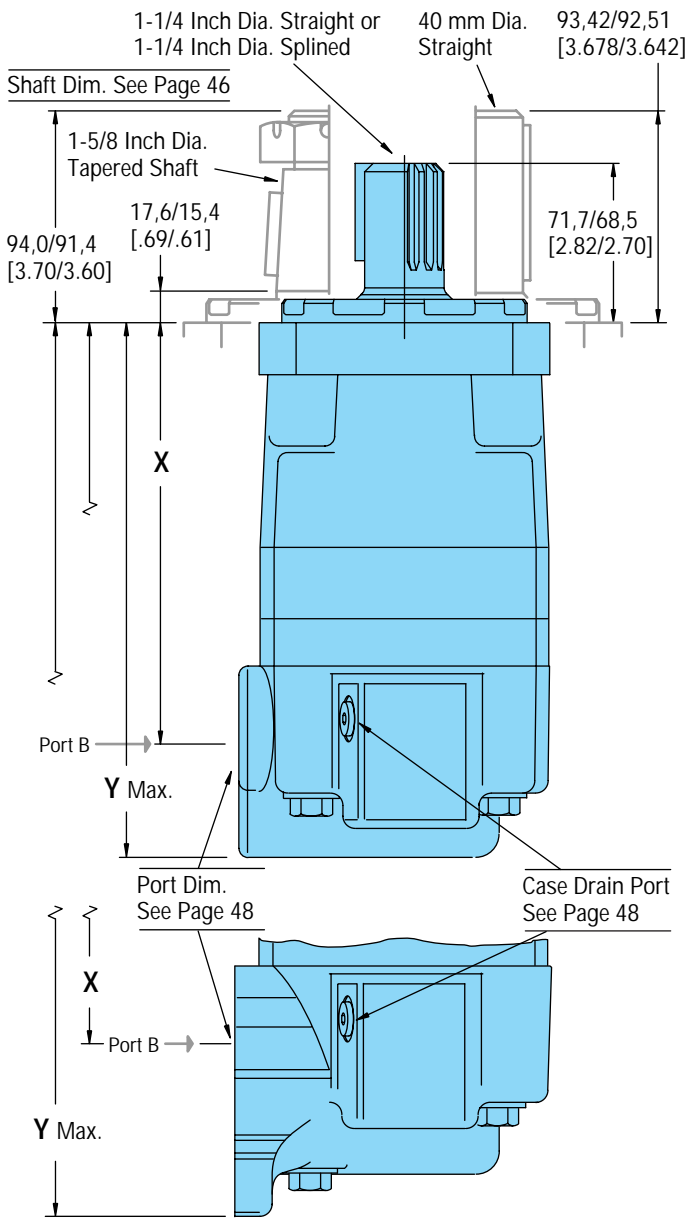

Standard Flange— Similar to SAE B Type

Standard Rotation
Viewed from Shaft End
Port A Pressurized — CW
Port B Pressurized — CCW

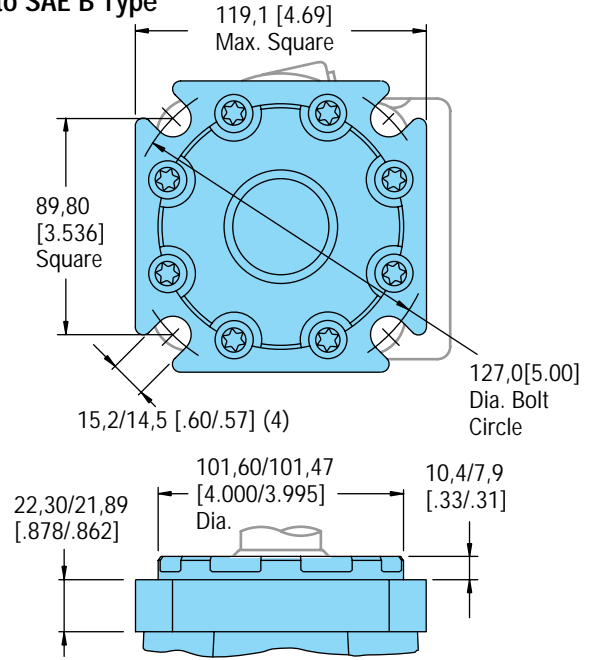

SAE C Flange

14,53/14,15 [572/557] Dia. Thru Max.

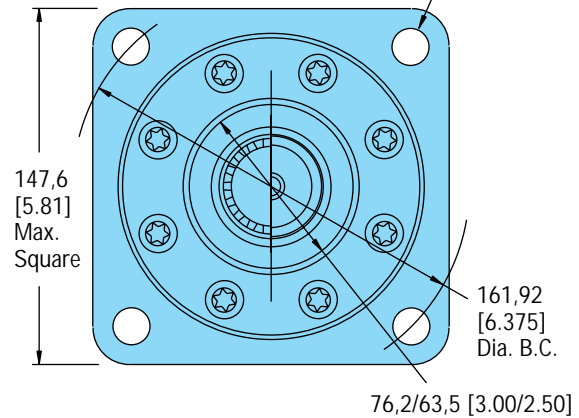

4000 Series Standard Motor with 1-1/16-12 O-ring Ports or G 3/4 (BSP) Ports

Displ. cm ³ /r [in ³ /r]	110 [6.7]	130 [7.9]	160 [9.9]	205 [12.5]	245 [15.0]	310 [19.0]	395 [24.0]	495 [30.0]	625 [38.0]
X Dim. mm [inch]	158,3 [6.23]	162,3 [6.39]	168,7 [6.64]	177,2 [6.98]	168,7 [6.64]	177,2 [6.98]	187,9 [7.40]	200,7 [7.90]	217,8 [8.58]
Y Dim. mm [inch]	214,4 [8.44]	218,4 [8.60]	224,7 [8.85]	233,2 [9.18]	224,7 [8.85]	233,2 [9.18]	243,9 [9.60]	256,8 [10.11]	273,9 [10.78]

4000 Series Standard Motor with 3/4 inch Split Flange Ports

X Dim. mm [inch]	166,7 [6.57]	170,8 [6.73]	177,0 [6.97]	185,6 [7.31]	177,1 [6.97]	185,6 [7.31]	196,3 [7.73]	209,2 [8.24]	226,2 [8.91]
Y Dim. mm [inch]	246,3 [9.70]	250,4 [9.86]	256,7 [10.11]	265,2 [10.44]	256,7 [10.11]	265,2 [10.44]	275,9 [10.86]	288,8 [11.37]	305,9 [12.04]

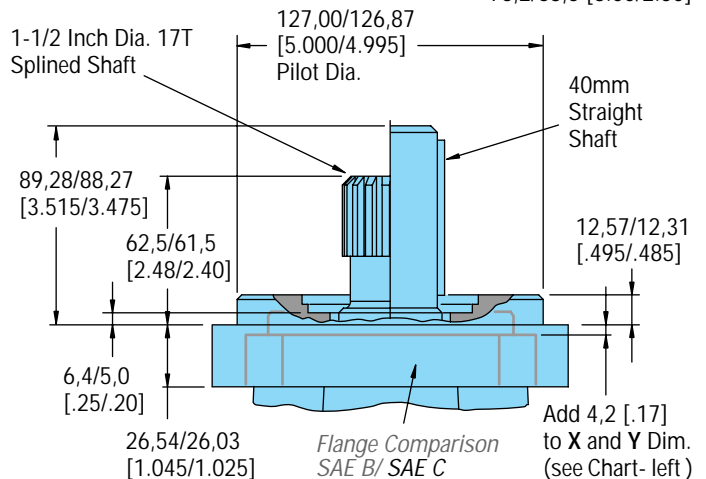

Dimensions — 4000 Series Wheel Motor

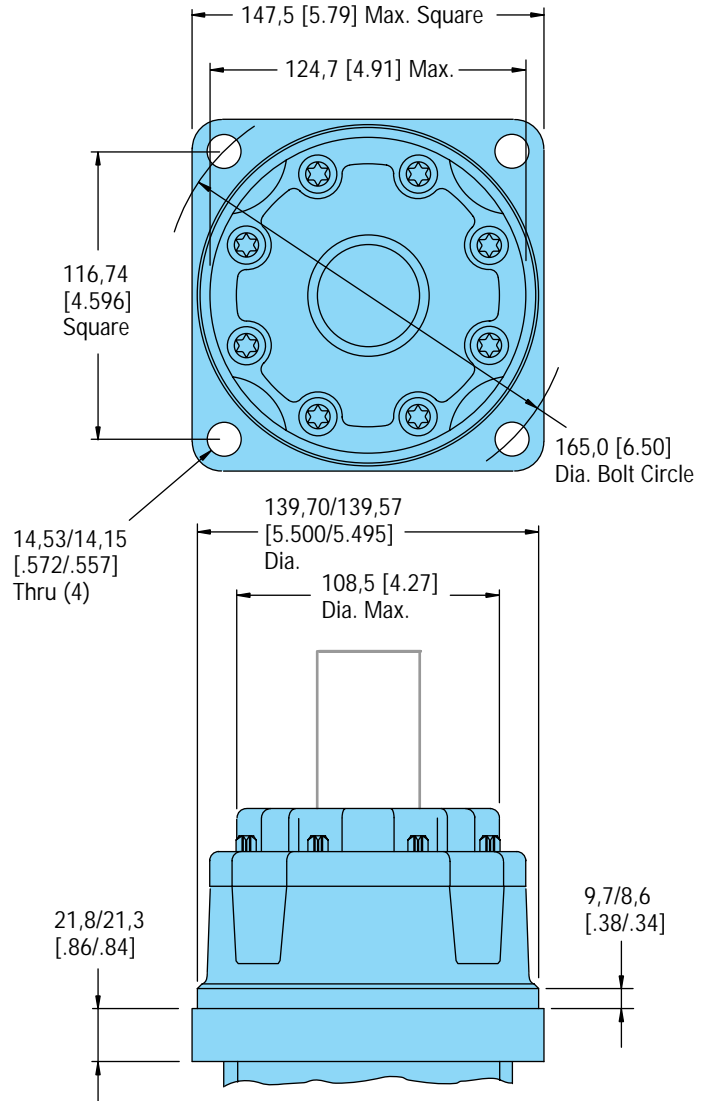
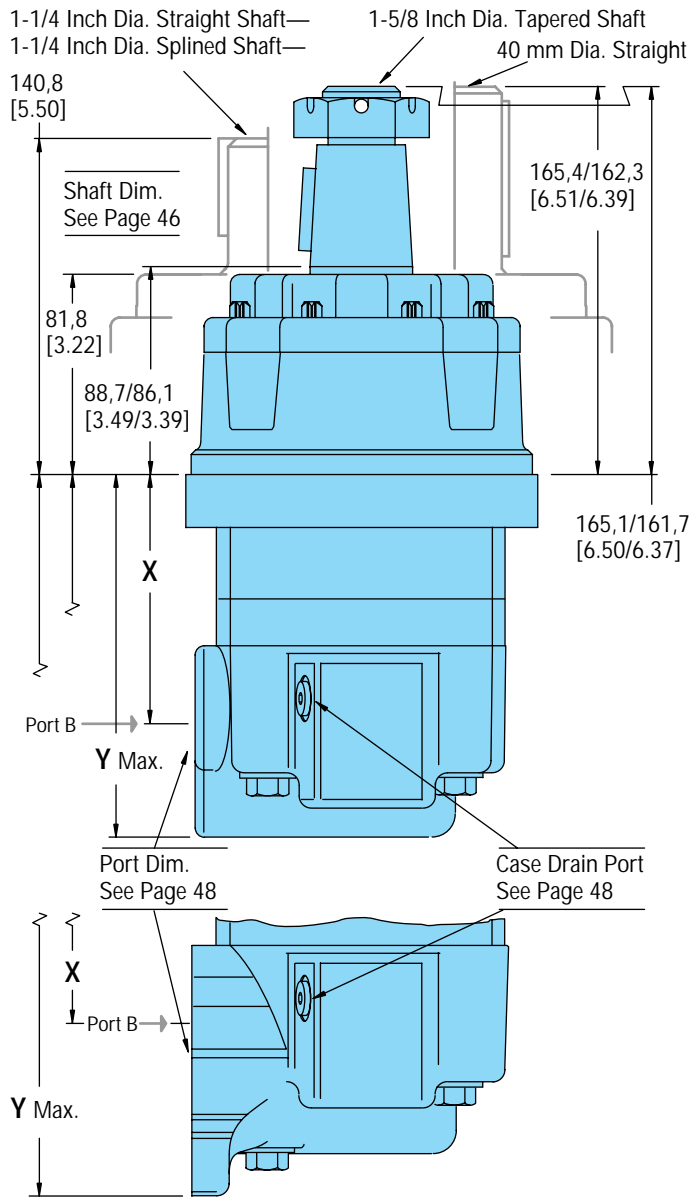

4000 Series Wheel Motor with 1-1/16-12 O-ring Ports or G 3/4 (BSP) Ports

Displ. cm ³ /r [in ³ /r]	110 [6.7]	130 [7.9]	160 [9.9]	205 [12.5]	245 [15.0]	310 [19.0]	395 [24.0]	495 [30.0]	625 [38.0]
X Dim. mm [inch]	87,4 [3.44]	91,5 [3.60]	97,8 [3.85]	106,3 [4.19]	97,8 [3.85]	106,3 [4.19]	117,0 [4.61]	129,9 [5.12]	146,8 [5.78]
Y Dim. mm [inch]	143,3 [5.64]	147,3 [5.80]	153,6 [6.05]	162,2 [6.38]	153,6 [6.05]	162,2 [6.38]	172,8 [6.80]	185,8 [7.31]	202,8 [7.98]

4000 Series Wheel Motor with 3/4 inch Split Flange Ports

X Dim. mm [inch]	95,0 [3.74]	99,1 [3.90]	105,5 [4.16]	114,0 [4.49]	105,5 [4.16]	114,0 [4.49]	124,7 [4.91]	137,6 [5.42]	154,4 [6.08]
Y Dim. mm [inch]	174,5 [6.87]	178,5 [7.03]	184,9 [7.28]	193,4 [7.61]	184,9 [7.28]	193,4 [7.61]	204,1 [8.03]	217,0 [8.54]	234,0 [9.21]

Standard Rotation
Viewed from Shaft End
Port A Pressurized — CW
Port B Pressurized — CCW

Dimensions — 4000 Series Bearingless Motor

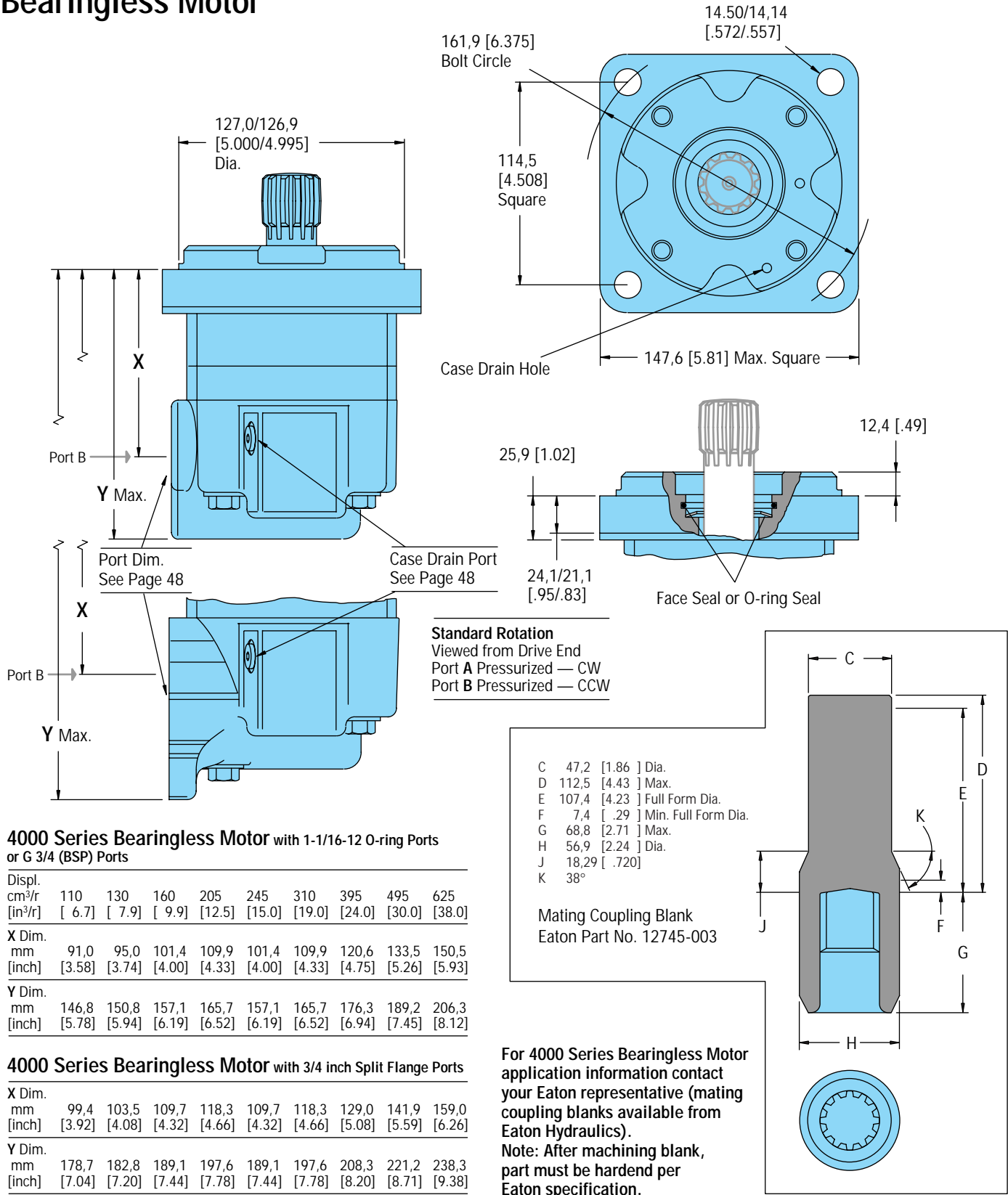

4000 Series Bearingless Motor with 1-1/16-12 O-ring Ports or G 3/4 (BSP) Ports

Displ.	110	130	160	205	245	310	395	495	625
cm ³ /r	110	130	160	205	245	310	395	495	625
[in ³ /r]	[6.7]	[7.9]	[9.9]	[12.5]	[15.0]	[19.0]	[24.0]	[30.0]	[38.0]

X Dim.									
mm	91,0	95,0	101,4	109,9	101,4	109,9	120,6	133,5	150,5
[inch]	[3.58]	[3.74]	[4.00]	[4.33]	[4.00]	[4.33]	[4.75]	[5.26]	[5.93]

Y Dim.									
mm	146,8	150,8	157,1	165,7	157,1	165,7	176,3	189,2	206,3
[inch]	[5.78]	[5.94]	[6.19]	[6.52]	[6.19]	[6.52]	[6.94]	[7.45]	[8.12]

4000 Series Bearingless Motor with 3/4 inch Split Flange Ports

X Dim.									
mm	99,4	103,5	109,7	118,3	109,7	118,3	129,0	141,9	159,0
[inch]	[3.92]	[4.08]	[4.32]	[4.66]	[4.32]	[4.66]	[5.08]	[5.59]	[6.26]

Y Dim.									
mm	178,7	182,8	189,1	197,6	189,1	197,6	208,3	221,2	238,3
[inch]	[7.04]	[7.20]	[7.44]	[7.78]	[7.44]	[7.78]	[8.20]	[8.71]	[9.38]

Bearingless Installation — 4000 Series

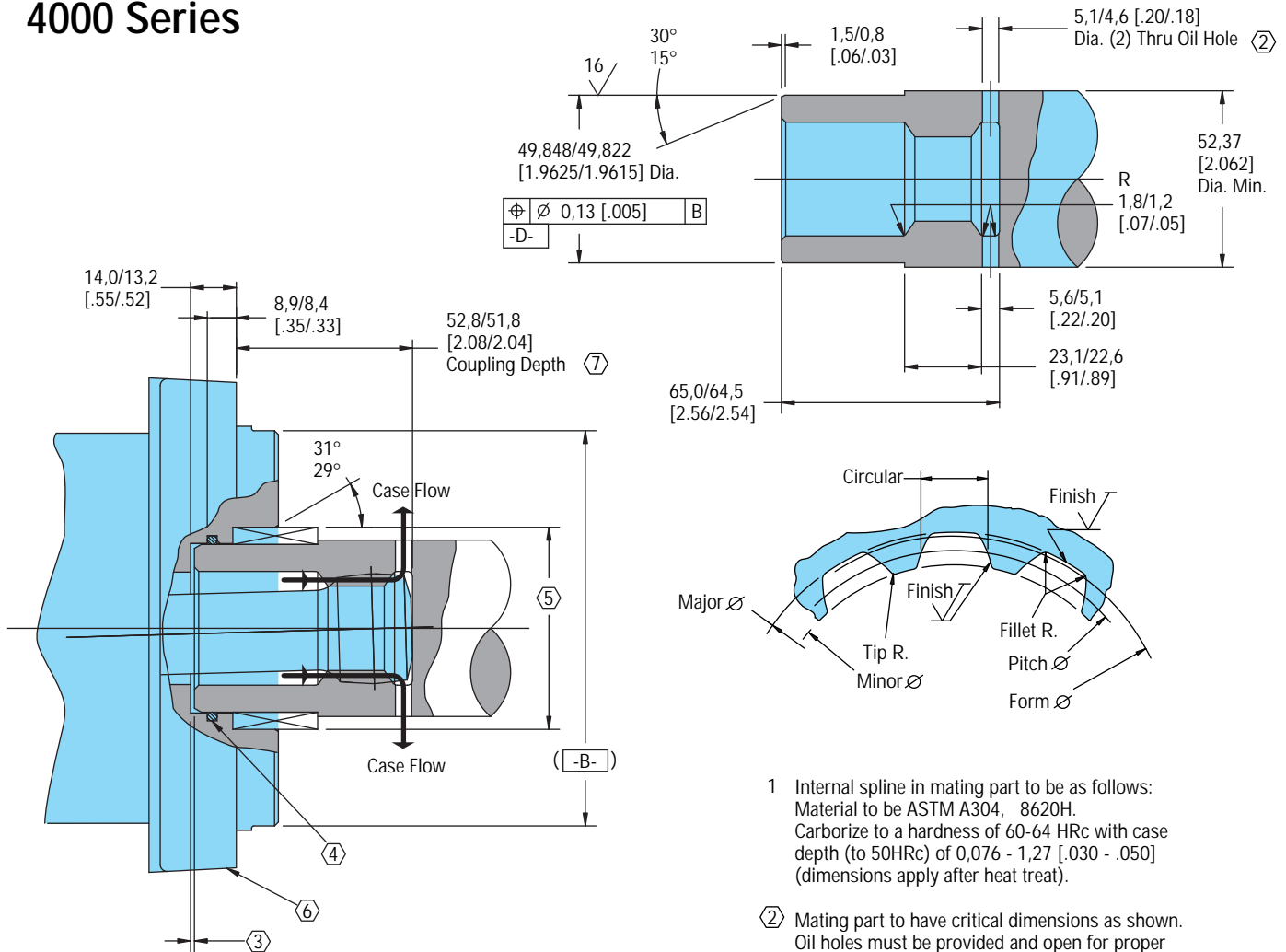

Spline Pitch — 10/20
 Pressure Angle — 30°
 Number of teeth — 12
 Class of Fit — Ref. 5
 Type of Fit — Side
 Pitch Diameter — Ref. 30.480000 [1.2000000] $\text{◎} 0.20 [0.008] H$
 Base Diameter — Ref. 26.396455 [1.0392305]
 Major Diameter — 33.43 [1.316] Max. 33.23 [1.308] Min.
 Minor Diameter — 28.40 - 28.58 [1.118 - 1.125]
 Form Diameter, Min. — 32.59 [1.283]
 Fillet Radius — 0.63 - 0.76 [0.025 - .030]
 Tip Radius — 0.26 - 0.51 [0.010 - .020]
 Finish — 1,6 [63]
 Involute Profile Variation — +0,000 -0,025 [+0.0000 -0.0010]
 Total Index Variation — 0,038 [0.0015]
 Lead Variation — 0,013 [0.0005]
 Circular Space Width:
 Maximum Actual — 5,045 [1.986]
 Minimum Effective — 4,995 [1.951]
 Maximum Effective — Ref. 5,009 [1.972]
 Minimum Actual — Ref. 4,986 [1.963]
 Dimension Between Two Pins — Ref. 22,783 - 22,929 [.8970 - .9027]
 Pin Diameter — 5,334 [0.2100] Pins to Have 3,73 [0.147] Wide Flat for Root Clearance

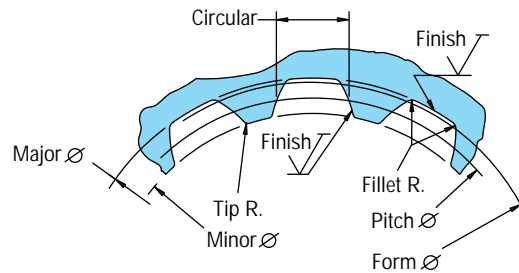

- 1 Internal spline in mating part to be as follows:
 Material to be ASTM A304, 8620H.
 Carborize to a hardness of 60-64 HRc with case depth (to 50HRc) of 0,076 - 1,27 [0.030 - .050] (dimensions apply after heat treat).
- 2 Mating part to have critical dimensions as shown. Oil holes must be provided and open for proper oil circulation.
- 3 Some means of maintaining clearance between shaft and mounting flange must be provided.
- 4 Seal to be furnished with motor for proper oil circulation thru splines.
- 5 Counterbore designed to adapt to a standard sleeve bearing 50,010 - 50,040 [1.9689 - 1.9700] ID by 60,050 - 60,080 [2.3642 - 2.3653] (Oilite bronze sleeve bearing).
- 6 Similar to SAE "C" Four Bolt Flange.
- 7 52,8 [2.08] Max. dimension to be maintained when assembling, shipping and installing unit to insure valve drive engagement with valve (this is required on displacement code number 24 only).

Dimensions — Shafts 4000 Series

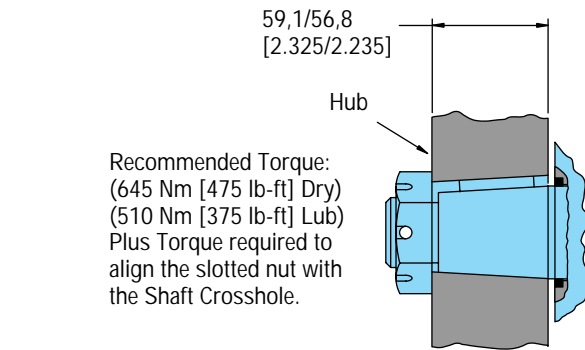
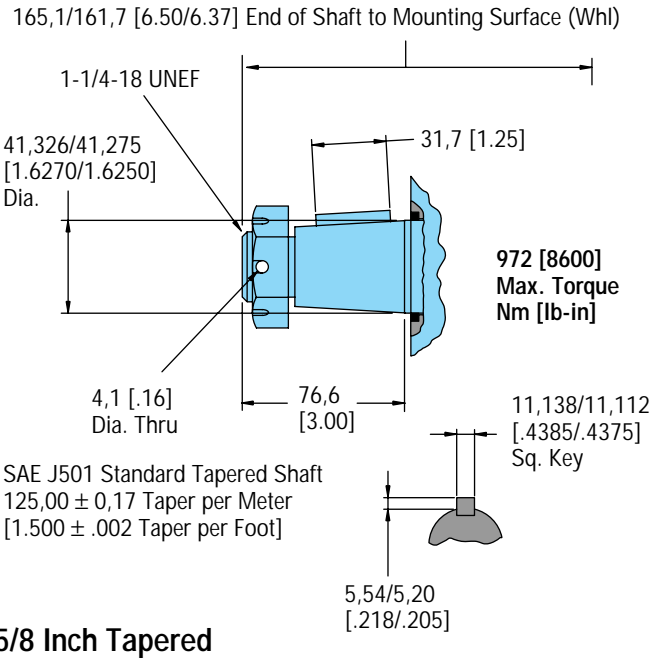
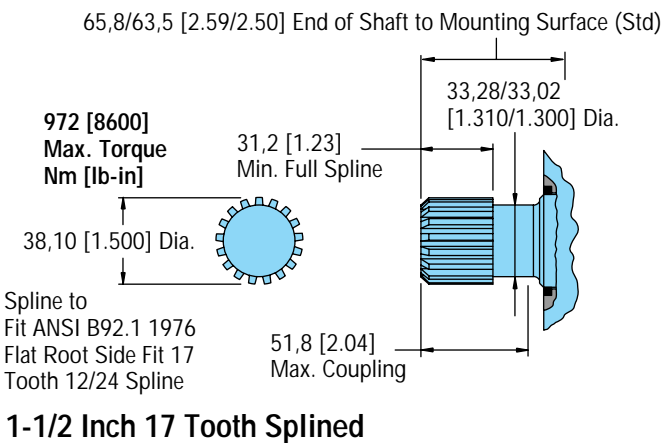
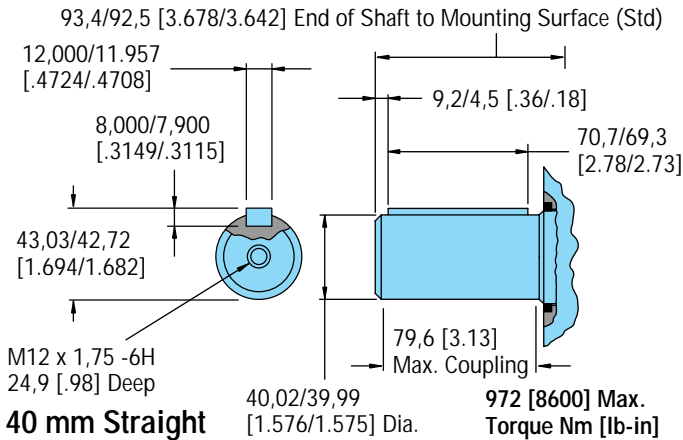
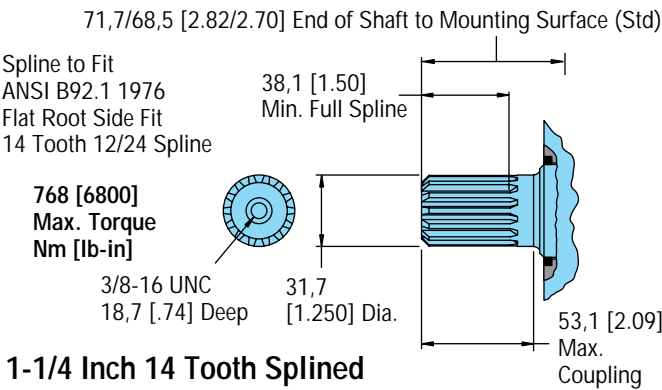
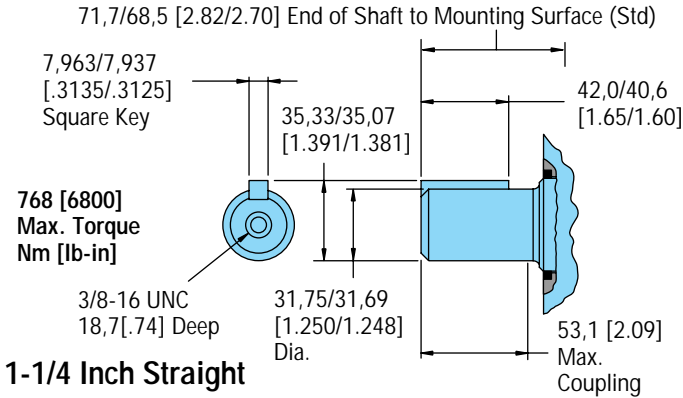

Tapered Shaft Hub Data

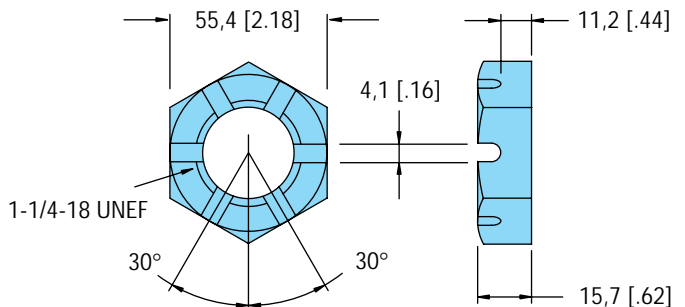

Slotted Hexagon Nut

Shaft Side Load Capacity 4000 Series

These curves indicate the radial load capacity on the motor shaft(s) at various locations.

The curve is based on **B 10 Bearing life (2000 hours or 12,000,000 shaft revolutions at 100 RPM) at rated output torque.** To determine radial load at speeds other than 100 RPM, multiply the load values given on the bearing curve by the factors in the chart below.

RPM	Multiplication Factor
50	1.23
100	1.00
200	.81
300	.72
400	.66
500	.62
600	.58
700	.56
800	.54

For 3,000,000 Shaft revolutions or 500 hours — Increase these shaft loads 52%.

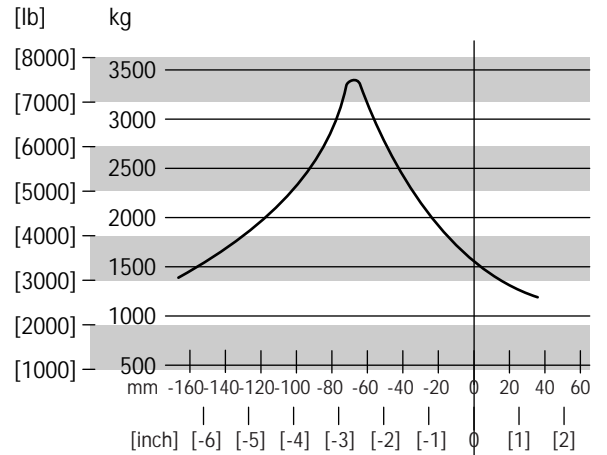

Wheel Motor
Tapered
Shaft

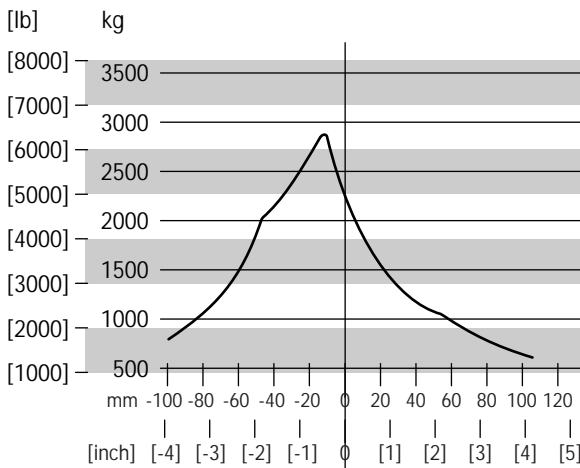
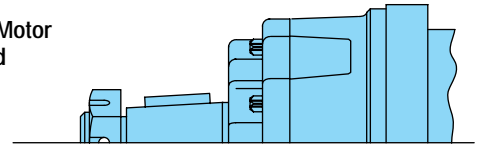

Standard Motor
Straight
Shaft

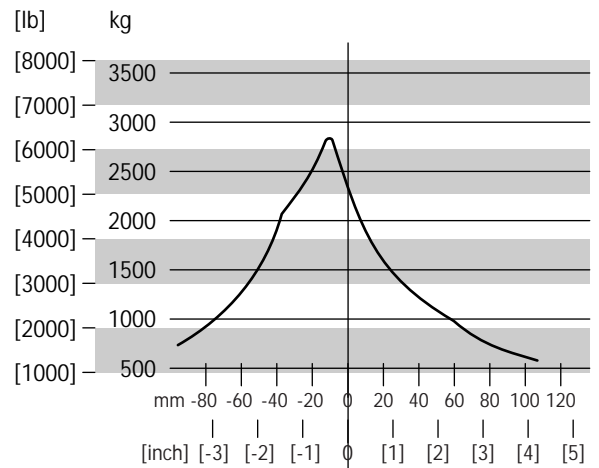
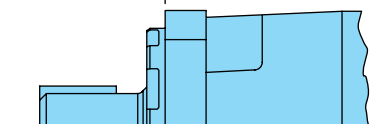

Standard Motor
Splined
Shaft

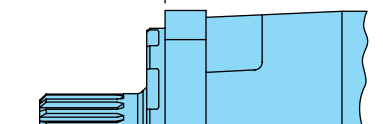

Dimensions — Ports 4000 Series

4000 Series with Shuttle Valve

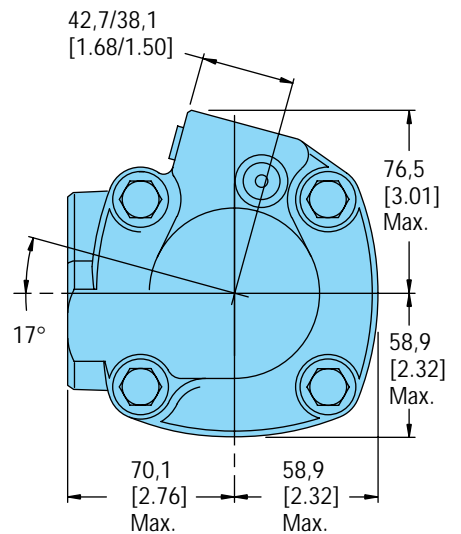
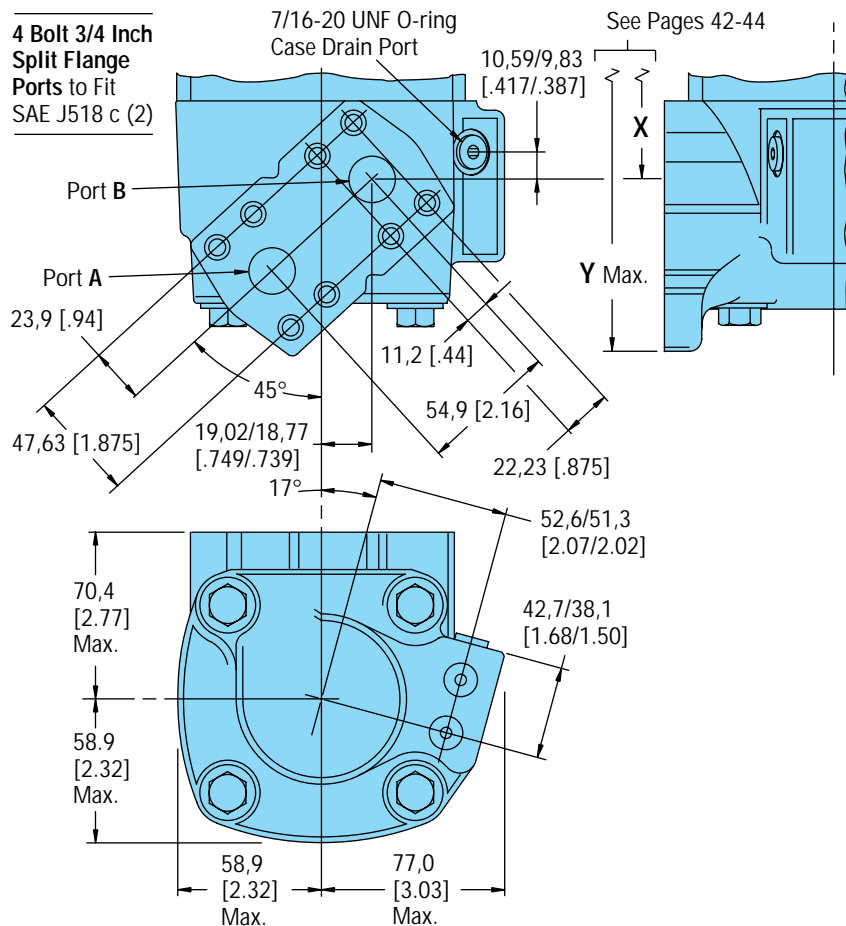
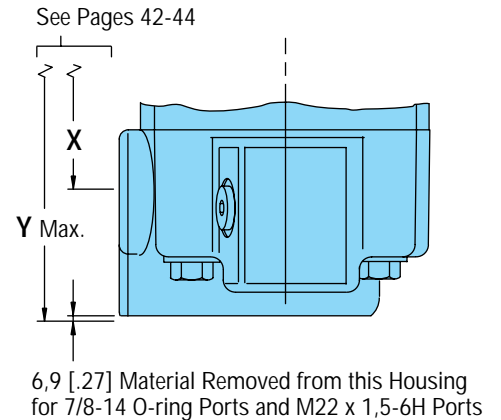
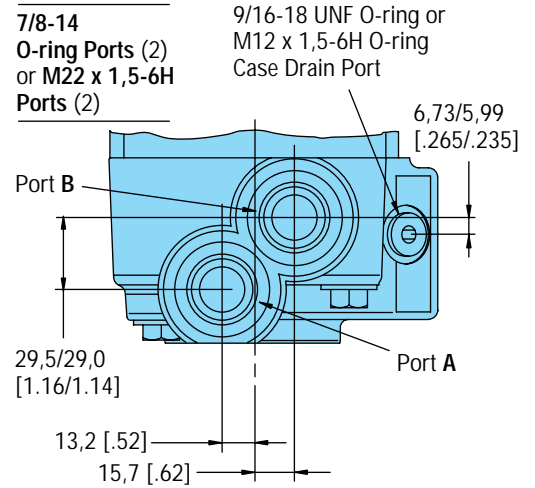
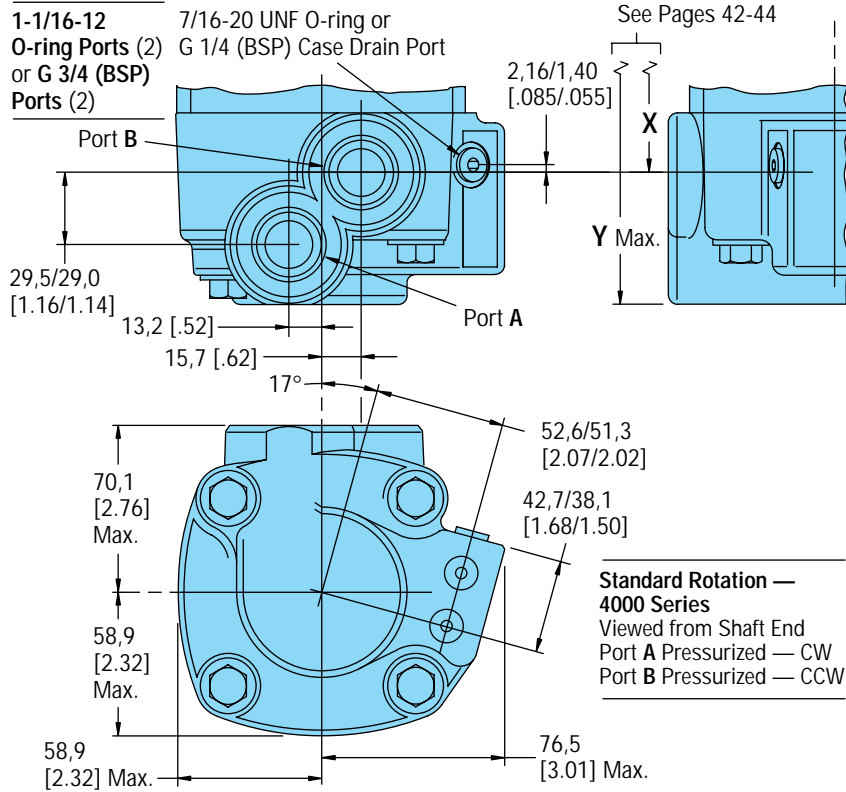

Product Numbers 4000 Series

Product Numbers—4000 Series Motors

Use digit prefix —**109-**, **110-**, or **111-** plus four digit number from charts for complete product number—Example **111-1057**.
Orders will not be accepted without three digit prefix.

Mounting	Shaft	Ports	Displ. cm ³ /r [in ³ /r] Product Number								
			110 [6.7]	130 [7.9]	160 [9.9]	205 [12.5]	245 [15.0]	310 [19.0]	395 [24.0]	495 [30.0]	625 [38.0]
Standard SAE B-Mount	1-1/4 inch Straight	1-1/16 O-ring	109-1100	-1101	-1102	-1103	-1104	-1105	-1106	-1212	-1215
		3/4 inch Split Flange	109-1001	-1054	-1002	-1003	-1055	-1056	-1057	—	—
	1-5/8 Inch Tapered	1-1/16 O-ring	109-1107	-1108	-1109	-1110	-1111	-1112	-1113	—	—
		3/4 inch Split Flange	109-1006	-1058	-1007	-1008	-1059	-1402	-1061	—	—
	1-1/4 Inch 14 T Splined	1-1/16 O-ring	109-1114	-1115	-1116	-1117	-1118	-1119	-1120	—	—
		3/4 inch Split Flange	109-1011	-1062	-1012	-1013	-1063	-1064	-1065	—	—
Standard SAE C-Mount	40 mm Straight	G 3/4 (BSP)	109-1184	-1185	-1227	-1224	-1225	-1189	-1190	—	—
	1-1/2 Inch 17 T Splined	G 3/4 (BSP)	109-1191	-1192	-1193	-1194	-1195	-1196	-1197	—	—
	1-1/4 inch Straight	1-1/16 O-ring	110-1074	-1075	-1076	-1077	-1078	-1079	-1080	—	-1122
		3/4 inch Split Flange	110-1001	-1040	-1002	-1003	-1041	-1042	-1043	—	—
Wheel Motor	40 mm Straight	G 3/4 (BSP)	110-1108	-1109	-1110	-1111	-1112	-1113	-1125	—	—
	1-5/8 Inch Tapered	1-1/16 O-ring	110-1081	-1082	-1083	-1084	-1085	-1086	-1087	1116	-1117
		3/4 inch Split Flange	110-1006	-1044	-1007	-1008	-1045	-1046	-1047	—	—
	1-1/4 Inch 14 T Splined	1-1/16 O-ring	110-1088	-1089	-1090	-1091	-1092	-1093	-1094	—	—
		3/4 inch Split Flange	110-1011	-1048	-1012	-1013	-1049	-1050	-1051	—	—
	Bearingless		1-1/16 O-ring	111-1033	-1034	-1035	-1036	-1037	-1038	-1039	-1062
		3/4 inch Split Flange	111-1044	-1015	-1045	-1046	-1016	-1017	-1018	—	—
		G 3/4 (BSP)	111-1052	-1053	-1054	-1055	-1056	-1057	-1058	—	—

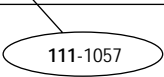

For 4000 Series Motors with a configuration *Not Shown* in the charts above: Use model code number system on page 50 to specify product in detail.

Model Code for 4000 Series Motors

The following 14-digit coding system has been developed to identify all of the configuration options for the 4000 Series Motor. Use this model code to specify a motor with the desired features. All 14-digits of the code must be present when ordering. You may want to photocopy the matrix below to ensure that each number is entered in the correct box.

Model Code — 4000 Series Disc Valve Motors

1	2	3	4	5	6	7	8	9	10	11	12	13	14
M	0	4										0	0

Position 1 Product Series

M Motor

Position 2, 3 4000 Series

04 4000 Series

Position 4, 5 Displacement cm³/r [in³/r]

07 110 [6.7]

08 130 [7.9]

10 160 [9.9]

12 205 [12.5]

15 245 [15.0]

17 280 [17.1]*

19 310 [19.0]

24 395 [24.0]

30 495 [30.0]

38 625 [38.0]

* For performance and dimension data contact your Eaton Hydraulics representative.

Position 6 Mounting Flange

A 4 Bolt (Bearingless 127,0 [5.00] Pilot Dia. and 14,27 [.562] Dia. Mounting Holes 161,9 [6.38] Dia. B.C.

B 4 Bolt (SAE B) (Standard) 101,6 [4.00] Pilot Dia. and 14,7 [.58] Mounting Slots on 127,0 [5.00] Dia. B.C.

C 4 Bolt (Wheel) 139,7 [5.50] Pilot Dia. and 14,3 [.56] Dia. Mounting Holes on 165,1 [6.50] Dia. B.C.

F 4 Bolt (SAE C) (Standard) 127,0 [5.00] Pilot Dia. and 14,3 [.56] Dia. Mounting Holes on 161,9 [6.38] Dia. B.C.

Position 7, 8 Output Shaft

00 Bearingless

01 1-1/4 inch Dia. Straight with Straight Key, 3/8-16 Threaded Hole and 53,1 [2.09] Max. Coupling Length

02 1-5/8 inch Dia. Tapered with Straight Key and 1-1/4 - 18 UNEF Slotted Hex. Nut

03 1-1/4 inch Dia. Splined 14T with 38,1 [1.50] Min. Full Spline Length and 53,1 [2.09] Max. Coupling Length

13 1-1/2 inch Dia. Splined 17T with 31,2 [1.23] Min. Full Spline Length

14 40 mm Dia. Straight with Straight Key, M12 x 1,75 - 6H Threaded Hole

Position 9 Port Type

B 1-1/16 - 12 O-ring with 7/16-20 O-ring Case Drain and Check Valve

C G 3/4 (BSP) O-ring with G 1/4 (BSP) O-ring Case Drain and Check Valve

D 3/4 inch 4 Bolt Split Flange with 7/16-20 O-ring Case Drain and Check Valve

A 7/8-14 O-ring with 9/16-18 O-ring Case Drain with Hot Oil Shuttle Valve

H M22 x 1,5-6H (ISO) O-ring with M12 x 1,5-6H O-ring Case Drain with Hot Oil Shuttle Valve

Position 10, 11 Special Features (Hardware)

00 None

01 Viton Shaft Seal

07 Viton Seals

13 Seal Guard

17 Speed Sensor (Std.)

Position 12 Paint/Special Packaging

0 No Paint

A Painted Low Gloss Black

C Corrosion Protected

Position 13 Eaton Assigned Code when Applicable

0 Assigned Code

Position 14 Eaton Assigned Design Code

0 Assigned Design Code

Specifications

6000 Series

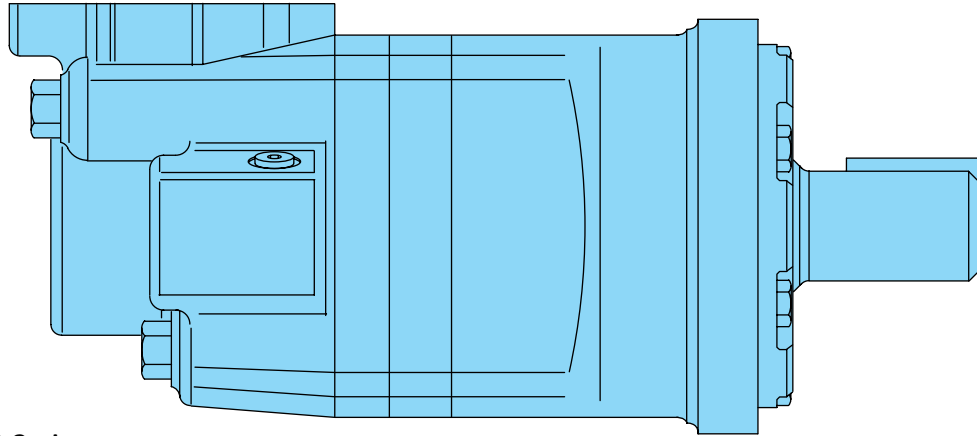

Specification Data—6000 Series

Displ. cm ³ /r [in ³ /r]		195 [11.9]	245 [15.0]	310 [19.0]	390 [23.9]	490 [30.0]	625 [38.0]	985 [60.0]	
Max. Speed (RPM) @ Flow	Continuous	775	615	485	387	307	241	153	
	Intermittent	866	834	698	570	454	355	230	
Flow LPM [GPM]	Continuous	150 [40]	150 [40]	150 [40]	150 [40]	150 [40]	150 [40]	150 [40]	
	Intermittent	170 [45]	210 [55]	225 [60]	225 [60]	225 [60]	225 [60]	225 [60]	
Torque Nm [lb-in]	★ 1-3/4 Inch Dia. Tapered Shaft	Continuous	575 [5100]	735 [6510]	930 [8230]	1155 [10230]	1445 [12800]	1480 [13100]	1685 [14920]
		Intermittent	860 [7620]	1100 [9740]	1355 [11990]	1635 [14490]	1885 [16670]	1898 [16800]	1875 [16580]
Pressure Δ Bar [Δ PSI]	★ 1-3/4 Inch Dia. Tapered Shaft	Continuous	205 [3000]	205 [3000]	205 [3000]	205 [3000]	205 [3000]	170 [2500]	140 [2000]
		Intermittent	310 [4500]	310 [4500]	310 [4500]	310 [4500]	275 [4000]	221 [3200]	140 [2000]
		Peak	310 [4500]	310 [4500]	310 [4500]	310 [4500]	310 [4500]	240 [3500]	170 [2250]

Maximum Case Pressure - without Case Drain * — 70 Bar [1000 PSI]

A simultaneous maximum torque and maximum speed NOT recommended. For permissible continuous and intermittent operating combinations of pressure and flow refer to performance data on pages 52-53.

★ **Maximum torque for 1-1/2 inch shaft** — 1325 Nm [11750 lb-in] Continuous and 1650 Nm [14600 lb-in] intermittent.

* For back pressure over 70 Bar [1000 PSI] use an external case drain. Install case drain lines so that the motor case remains filled at all times.

Maximum inlet pressure — 310 Bar [4500 PSI]. Do not exceed Δ pressure rating (see chart above).

* **Maximum return pressure** — 310 Bar [4500 PSI]. Do not exceed Δ pressure rating (see chart above).

Δ Bar [Δ PSI] — True pressure difference between inlet port and outlet port.

Continuous Rating — Motor may be run continuously at these ratings.

Intermittent Operation — 10% of every minute.

Peak Operation — 1% of every minute.

Recommended Fluids — Premium quality, anti-wear type hydraulic oil with a viscosity of not less than 70 SUS at operating temperature (see page 81).

Recommended Maximum System Operating Temp. — Is 82° C [180° F]

Recommended Filtration — per ISO Cleanliness Code, level 18/13

To assure best motor life, run motor for approximately one hour at 30% of rated pressure before application to full load. Be sure motor is filled with fluid prior to any load applications.

Performance

Data 6000 Series

195 cm³/r [11.9 in³/r]
Δ Pressure Bar [PSI]

	[250] 15	[500] 35	[1000] 70	[1500] 105	[2000] 140	[2500] 170	[3000] 205	[3500] 240	[4000] 275	[4500] 310
[.5]	[280] 30 9	[650] 75 7	[1450] 165 5	[2290] 260 2						
[2]	[290] 35 38	[680] 75 37	[1500] 170 34	[2340] 265 30	[3100] 350 26	[3880] 440 18	[4140] 470 18			
[4]	[300] 35 77	[710] 80 76	[1500] 175 74	[2390] 270 72	[3210] 365 66	[4030] 455 62	[4600] 520 46	[5200] 590 32	[5790] 655 18	
[8]	[310] 35 154	[740] 85 155	[1590] 180 148	[2450] 275 144	[3280] 370 131	[4120] 465 119	[4810] 545 116	[5530] 625 99	[6250] 705 83	[6900] 780 65
[12]	[320] 35 232	[750] 85 230	[1610] 180 225	[2480] 280 221	[3330] 375 212	[4190] 475 203	[4990] 565 186	[5810] 655 167	[6630] 750 148	[7320] 825 118
[16]	[300] 35 309	[730] 80 307	[1600] 180 303	[2470] 280 300	[3340] 375 291	[4210] 475 283	[5090] 575 258	[5900] 665 236	[6710] 760 214	[7470] 845 181
[20]	[270] 30 387	[720] 80 384	[1590] 180 379	[2460] 280 374	[3350] 380 365	[4240] 480 356	[5100] 575 332	[5950] 670 306	[6800] 770 280	[7620] 860 247
[24]	[240] 25 465	[700] 80 462	[1570] 175 456	[2440] 275 450	[3330] 375 440	[4220] 475 429	[5080] 575 413	[5940] 670 388	[6810] 770 363	
[28]	[190] 20 542	[660] 75 539	[1530] 175 532	[2400] 275 526	[3300] 370 514	[4200] 475 502	[5060] 575 476	[5940] 670 448	[6810] 770 421	
[32]	[160] 20 620	[630] 70 617	[1500] 170 609	[2370] 270 602	[3270] 370 589	[4160] 470 576	[5040] 570 542	[5920] 670 511	[6790] 765 480	
[36]	[120] 15 697	[620] 70 692	[1480] 165 683	[2350] 265 674	[3240] 365 659	[4130] 465 645	[5000] 565 601	[5880] 665 564	[6760] 765 527	
[40]	[80] 10 775	[610] 70 770	[1450] 165 759	[2320] 260 749	[3210] 365 733	[4100] 465 718	[4960] 560 666	[5840] 660 624		
[45]		[590] 65 866	[1410] 160 854	[2280] 260 843	[3170] 360 825	[4060] 460 808	[4920] 555 749	[5790] 655 702		

245 cm³/r [15.0 in³/r]
Δ Pressure Bar [PSI]

	[250] 15	[500] 35	[1000] 70	[1500] 105	[2000] 140	[2500] 170	[3000] 205	[3500] 240	[4000] 275	[4500] 310
[.5]	[430] 50 7	[860] 95 4	[1890] 215 1							
[2]	[440] 50 30	[900] 100 29	[1940] 220 26	[2990] 340 24	[3960] 445 21	[4920] 555 17	[5040] 570 11	[5930] 670 6		
[4]	[460] 50 61	[940] 105 60	[2000] 225 56	[3060] 345 54	[4080] 460 48	[5090] 575 42	[5680] 640 39	[6630] 750 30	[7570] 855 12	[8520] 965 6
[8]	[470] 55 122	[960] 110 120	[2060] 235 116	[3150] 355 113	[4210] 475 104	[5260] 595 95	[6180] 700 81	[7100] 800 67	[8020] 905 53	[9020] 1020 37
[12]	[480] 55 183	[970] 110 182	[2080] 235 180	[3180] 360 178	[4270] 480 165	[5360] 605 157	[6390] 720 141	[7420] 840 125	[8450] 955 109	[9510] 1075 92
[16]	[450] 50 245	[960] 110 244	[2070] 235 240	[3180] 360 236	[4290] 480 228	[5420] 610 221	[6480] 730 202	[7490] 845 184	[8480] 940 165	[9540] 1180 145
[20]	[420] 45 307	[940] 105 306	[2050] 230 301	[3160] 355 297	[4290] 485 287	[5440] 615 277	[6510] 735 257	[7580] 855 238	[8660] 960 218	[9740] 1100 197
[24]	[380] 45 368	[920] 105 365	[2020] 230 361	[3120] 355 358	[4260] 480 348	[5400] 610 338	[6490] 735 316	[7590] 860 294	[8680] 980 271	
[28]	[330] 35 430	[870] 100 426	[1980] 225 421	[3100] 350 416	[4240] 480 404	[5380] 610 376	[6480] 730 358	[7580] 855 340	[8670] 980 322	
[32]	[290] 35 491	[800] 90 489	[1920] 215 481	[3050] 345 475	[4170] 470 461	[5290] 600 448	[6410] 720 423	[7520] 850 398	[8640] 975 373	
[36]	[250] 30 556	[730] 80 549	[1850] 210 543	[2980] 335 524	[4060] 460 509	[5150] 580 482	[6300] 710 485	[7440] 840 456		
[40]	[200] 25 615	[690] 80 612	[1790] 200 606	[2940] 330 599	[4010] 455 585	[5130] 580 570	[6190] 700 540	[7100] 800 510		
[45]		[570] 65 688	[1760] 200 682	[2860] 325 674	[3960] 445 658	[5070] 575 641	[6080] 685 608	[6690] 755 574		
[50]			[1720] 195 758	[2800] 315 749	[3890] 440 731	[4920] 555 712	[5940] 670 676			
[55]			[1670] 190 834	[2740] 310 824	[3820] 430 804	[4890] 550 783	[5880] 665 744			
[208]										

Motors run with high efficiency in all areas designated with a number for torque and speed, however for best motor life select a motor to run with a torque and speed range shown in the light blue area.

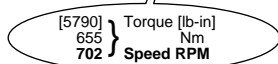

Performance data is typical at 120 SUS. Actual data may vary slightly from unit to unit in production

310 cm³/r [19.0 in³/r]
Δ Pressure Bar [PSI]

	[250] 15	[500] 35	[1000] 70	[1500] 105	[2000] 140	[2500] 170	[3000] 205	[3500] 240	[4000] 275	[4500] 310
[.5]	[530] 60 6	[1120] 125 4	[2440] 275 1							
[2]	[540] 60 24	[1150] 130 23	[2460] 280 22	[3620] 410 20	[4780] 540 14	[5690] 645 10	[6670] 755 4	[7780] 880		
[4]	[550] 60 48	[1180] 135 47	[2560] 290 45	[3800] 430 42	[5030] 570 32	[6050] 685 32	[7070] 800 24	[8260] 935 17	[9070] 1025 10	[9530] 1075 3
[8]	[560] 65 96	[1250] 140 95	[2650] 300 91	[3970] 450 87	[5280] 595 81	[6480] 730 73	[7710] 870 64	[8740] 985 55	[9770] 1105 46	[10990] 1240 35
[12]	[570] 65 144	[1260] 140 143	[2690] 305 140	[4050] 460 135	[5420] 610 129	[6730] 760 121	[8040] 910 111	[9260] 1045 99	[10490] 1185 88	[11800] 1335 76
[16]	[540] 60 193	[1230] 140 192	[2660] 300 188	[4060] 460 184	[5450] 615 178	[6800] 770 167	[8150] 920 156	[9400] 1060 141	[10660] 1205 126	[11990] 1355 109
[20]	[510] 60 242	[1200] 135 241	[2630] 295 236	[4040] 455 232	[5450] 615 226	[6820] 770 216	[8190] 925 201	[9520] 1075 184	[10840] 1225 167	
[24]	[480] 55 290	[1160] 130 289	[260] 295 282	[4020] 455 279	[5440] 615 273	[6840] 775 260	[8230] 930 248	[9560] 1080 232	[10900] 1230 215	
[28]	[420] 45 339	[1130] 130 336	[2570] 290 333	[3990] 450 328	[5420] 610 320	[6820] 770 308	[8220] 930 295	[9520] 1075 276	[10840] 1225 257	
[32]	[360] 40 388	[1100] 125 384	[2510] 285 381	[3920] 445 375	[5330] 600 354	[6750] 765 354	[8170] 920 341	[9440] 1065 320		
[36]	[300] 35 436	[1060] 120 430	[2440] 275 421	[3830] 435 416	[5220] 590 410	[6660] 750 396	[8100] 915 383	[9330] 1055 360		
[40]	[270] 30 485	[1020] 115 478	[2400] 270 466	[3780] 425 461	[5150] 580 445	[6580] 745 427	[8020] 905 407	[9220] 1040 403		
[50]		[982] 110 597	[2180] 245 582	[3420] 385 576	[4660] 525 551	[6050] 685 551	[7440] 840 534			
[60]			[1960] 220 698	[3250] 365 691	[4540] 515 684	[5750] 650 661	[7080] 800 641			
[227]										

390 cm³/r [23.9 in³/r]
Δ Pressure Bar [PSI]

	[250] 15	[500] 35	[1000] 70	[1500] 105	[2000] 140	[2500] 170	[3000] 205	[3500] 240	[4000] 275	[4500] 310
[1]	[760] 85 4	[1570] 175 2	[3230] 365 1							
[3.8]	[780] 90 19	[1610] 180 18	[3270] 370 17	[4910] 555 16	[6440] 730 14	[7760] 875 12	[9080] 1025 9	[10590] 1195 4		
[7.5]	[800] 90 38	[1640] 185 38	[3300] 375 37	[4970] 560 35	[6570] 740 33	[8000] 920 29	[9570] 1080 22	[11270] 1275 14	[12120] 1370 5	[14490] 1635 1
[15]	[810] 90 77	[1650] 185 76	[3370] 380 74	[5080] 575 72	[6740] 760 68	[8430] 950 65	[10050] 1135 55	[11620] 1315 45	[12880] 1455 33	[14480] 1635 21
[30]	[800] 90 115	[1620] 185 115	[3390] 385 112	[5130] 580 109	[6810] 770 105	[8520] 965 100	[10190] 1150 91	[11860] 1340 81	[13640] 1540 79	
[45]	[750] 85 154	[1600] 180 154	[3380] 380 151	[5120] 580 147	[6820] 770 143	[8560] 965 132	[10230] 1155 126	[11920] 1345 116		
[20]	[680] 75 193	[1580] 180 193	[3360] 380 189	[5120] 580 187	[6840] 775 182	[8590] 970 175	[10280] 1160 162	[11980] 1355 152		
[76]										
[24]	[620] 70 232	[1520] 170 230	[3280] 370 229	[5060] 570 225	[6780] 765 220	[8530] 965 212	[10240] 1155 204			
[91]										
[28]	[570] 65 270	[1460] 165 268	[3210] 365 266	[5000] 565 261	[6730] 760 256	[8490] 960 248	[10200] 1150 236			
[106]										
[32]	[530] 60 309	[1420] 160 306	[3140] 355 304	[4930] 555 299	[6640] 750 292	[8380] 945 282	[10120] 1145 269			
[121]										
[36]	[450] 50 348	[1370] 155 346	[3010] 340 340	[4840] 545 336	[6500] 730 329	[8250] 930 317	[10000] 1130 301			
[136]										
[40]	[380] 45 387	[1320] 150 386	[2880] 325 380	[4740] 535 375	[6460] 730 368	[8120] 915 359				
[151]										
[50]		[1140] 130 482	[2650] 300 475	[4540] 515 469	[6440] 730 460	[8050] 910 449				

Performance Data 6000 Series

490 cm³/r [30.0 in³/r]
Δ Pressure Bar [PSI]

	[250] 15	[500] 35	[1000] 70	[1500] 105	[2000] 140	[2500] 170	[3000] 205	[3500] 240	[4000] 275
[1] 3.8	[1010] 115 7	[1200] 235 7	[4260] 480 5	[6140] 695 3					
[2] 7.5	[1020] 115 15	[2110] 240 14	[4270] 480 13	[6280] 710 12	[8350] 945 11	[10420] 1175 8	[12140] 1370 3		
[4] 15	[1030] 115 30	[2100] 235 30	[4280] 485 29	[6410] 725 28	[8500] 960 27	[10590] 1195 25	[12500] 1410 21	[14580] 1645 17	[16670] 1885 12
[8] 30	[1020] 115 60	[2090] 235 60	[4290] 485 59	[6490] 735 57	[8620] 975 54	[10740] 1215 51	[12800] 1445 45	[14930] 1685 38	
[12] 45	[1000] 115 91	[2080] 235 91	[4290] 485 89	[6500] 735 87	[8650] 975 84	[10800] 1220 79	[12890] 1455 71		
[16] 61	[110] 960 122	[2060] 235 122	[4260] 480 121	[6480] 730 118	[8650] 975 114	[10820] 1220 109	[12900] 1460 100		
[20] 76	[900] 100 153	[1980] 225 152	[4180] 470 150	[6420] 725 147	[8620] 975 144	[10820] 1220 139			
[24] 91	[850] 95 184	[1930] 220 184	[4150] 470 181	[6390] 720 180	[8580] 970 176	[10770] 1215 171			
[28] 106	[740] 85 215	[1840] 210 214	[4070] 460 211	[6290] 710 208	[8500] 960 204	[10720] 1210 198			
[32] 121	[690] 80 245	[1710] 195 244	[3970] 450 241	[6190] 700 237	[8420] 950 232	[10660] 1205 226			
[36] 136	[670] 75 276	[1560] 175 275	[3860] 435 272	[6080] 685 265	[8340] 940 260	[10420] 1175 255			
[40] 151	[570] 65 307	[1400] 160 306	[3750] 425 303	[5970] 675 295	[8140] 920 290	[10180] 1150 284			
[50] 189		[1140] 130 382	[3240] 365 379	[5220] 590 369	[7620] 860 362				
[60] 227			[2860] 325 454	[4860] 550 442	[7140] 805 435				

625 cm³/r [38.0 in³/r]
Δ Pressure Bar [PSI]

	[250] 15	[500] 35	[1000] 70	[1500] 105	[2000] 140	[2500] 170	[3000] 205	[3200] 221
[1] 3.8	[1060] 120 5	[2205] 250 5	[4515] 510 4	[6690] 755 2				
[2] 7.5	[1090] 125 12	[2300] 260 12	[4720] 535 13	[6705] 790 10	[9360] 1060 6			
[4] 15	[1145] 130 24	[2450] 275 24	[5052] 570 24	[7520] 850 21	[9410] 1065 16	[12700] 1434 13		
[8] 30	[1195] 135 45	[2600] 295 45	[5350] 605 44	[8195] 925 42	[11220] 1270 37	[13100] 1480 35	[15800] 1785 32	[16800] 1898 30
[12] 45	[1200] 135 72	[2600] 295 72	[5390] 610 71	[8145] 920 82	[11770] 1330 64	[13000] 1469 60	[15700] 1774 56	
[16] 61	[1120] 125 94	[2530] 285 94	[5340] 605 92	[8105] 915 89	[11740] 1325 85	[13000] 1469 83		
[20] 76	[1050] 120 120	[2465] 280 119	[5285] 595 117	[8080] 915 115	[11725] 1325 110			
[24] 91	[950] 105 144	[2365] 265 143	[5180] 585 140	[7990] 905 138	[11705] 1320 132			
[28] 106	[855] 95 169	[2255] 255 168	[5080] 575 165	[7915] 895 162	[11640] 1315 156			
[32] 121	[730] 80 193	[2140] 240 192	[4960] 560 188	[7775] 880 185	[11505] 1300 179			
[36] 136	[555] 65 217	[1965] 220 216	[4780] 540 213	[7585] 855 210				
[40] 151	[380] 45 241	[1790] 200 240	[4600] 520 238	[7395] 835 236				
[50] 189			[4180] 470 296	[6985] 790 290				
[60] 227			[3800] 430 353	[6600] 745 345				

Motors run with high efficiency in all areas designated with a number for torque and speed, however for best motor life select a motor to run with a torque and speed range shown in the light blue area.

Continuous
Intermittent

[3800]
430
353 } Torque [lb-in]
Nm
Speed RPM

Performance data is typical at 120 SUS. Actual data may vary slightly from unit to unit in production

805 cm³/r [49.0 in³/r]
Δ Pressure Bar [PSI]

	[250] 15	[500] 35	[750] 50	[1000] 70	[1250] 85	[1500] 105	[1750] 120	[2000] 140	[2250] 155	[2500] 170
[1] 3.8	[1455] 164 4	[3100] 350 4	[4680] 529 2	[6031] 681 2	[7799] 881 1					
[2] 7.5	[1483] 168 9	[3173] 359 9	[5121] 579 9	[6432] 727 8	[8510] 961 7	[9633] 1088 6	[11319] 1279 5	[12127] 1370 5		
[4] 15	[1547] 175 19	[3331] 376 19	[5292] 598 18	[6744] 762 17	[8714] 984 16	[10075] 1138 15	[11352] 1283 14	[12539] 1417 12	[14564] 1645 11	[16377] 1850 10
[8] 30	[1599] 181 35	[3473] 392 35	[5415] 612 34	[7039] 795 33	[8934] 1009 32	[10629] 1204 31	[11842] 1338 29	[14004] 1582 29	[15441] 1745 28	
[12] 45	[1599] 181 56	[3469] 392 56	[5415] 612 55	[7093] 795 53	[9024] 1020 53	[10658] 1204 52	[12283] 1388 50	[13726] 1551 50		
[16] 61	[1543] 174 73	[3395] 384 73	[5357] 605 72	[7032] 794 70	[8983] 1015 69	[10640] 1202 68	[12010] 1357 67			
[20] 76	[1457] 165 93	[3312] 374 92	[5292] 598 91	[6968] 787 89	[8943] 1010 88	[10583] 1196 87	[12146] 1372 86			
[24] 91	[1352] 153 112	[3183] 360 112	[5088] 575 111	[6811] 769 110	[8812] 996 108	[10411] 1176 106				
[28] 106	[1213] 137 131	[3055] 345 131	[5047] 570 131	[6713] 758 129	[8681] 981 128	[10411] 1176 127				
[32] 121	[1075] 121 150	[2907] 328 149	[4884] 552 149	[6546] 740 146	[8395] 949 145	[10060] 1137 144				
[36] 136	[823] 93 168	[2692] 304 168	[4663] 527 168	[6320] 714 167	[8118] 917 165					
[40] 151	[592] 67 187	[2477] 280 186	[4426] 500 186	[6085] 688 185	[7832] 885 184					
[50] 189		[2730] 308 234	[4214] 476 233	[5849] 661 231	[7603] 859 230					
[60] 227			[3806] 430 280	[5459] 617 277	[7407] 837 275					

985 cm³/r [60.0 in³/r]
Δ Pressure Bar [PSI]

	[250] 15	[500] 35	[750] 50	[1000] 70	[1250] 85	[1500] 105	[1750] 120	[2000] 140
[1] 3.8	[1890] 215 3	[4110] 465 3	[5730] 645 2	[7640] 865 2	[9550] 1080 1			
[2] 7.5	[1910] 215 8	[4140] 470 8	[6270] 710 7	[8300] 940 7	[10420] 1175 6	[12500] 1410 5	[13860] 1565 4	[14920] 1685 3
[4] 15	[1980] 225 15	[4290] 485 15	[6480] 775 15	[8540] 965 14	[10670] 1205 14	[12800] 1445 13	[13900] 1570 13	[15850] 1790 12
[8] 30	[2030] 230 30	[4400] 495 30	[6630] 750 30	[8790] 995 29	[10940] 1235 28	[13090] 1480 27	[14500] 1640 26	[16580] 1875 25
[12] 45	[2020] 230 45	[4390] 495 45	[6630] 750 45	[8800] 995 44	[11050] 1250 43	[13240] 1495 42	[15040] 1700 41	
[16] 61	[2010] 225 61	[4320] 490 61	[6560] 740 61	[8790] 995 60	[11000] 1245 59	[13260] 1500 58		
[20] 76	[1910] 215 77	[4220] 475 77	[6480] 730 76	[8720] 985 76	[10950] 1235 75	[13160] 1485 74		
[24] 91	[1810] 205 92	[4060] 460 92	[6230] 705 92	[8500] 960 91	[10790] 1220 90	[12990] 1470 89		
[28] 106	[1620] 185 107	[3920] 445 107	[6180] 700 107	[8420] 950 106	[10630] 1200 105	[12820] 1450 103		
[32] 121	[1480] 165 123	[3740] 425 123	[5980] 675 122	[8200] 925 121	[10280] 1160 120			
[36] 136	[1140] 130 138	[3490] 395 138	[5710] 645 138	[7930] 895 137	[9940] 1125 135			
[40] 151	[850] 95 153	[3240] 365 153	[5420] 610 152	[7640] 865 151	[9590] 1085 150			
[50] 189		[2960] 325 191	[5160] 585 190	[7350] 830 189	[9310] 1050 188			
[60] 227			[4660] 525 230	[7160] 810 229	[9070] 1025 226			

Dimensions — 6000 Series Standard Motor

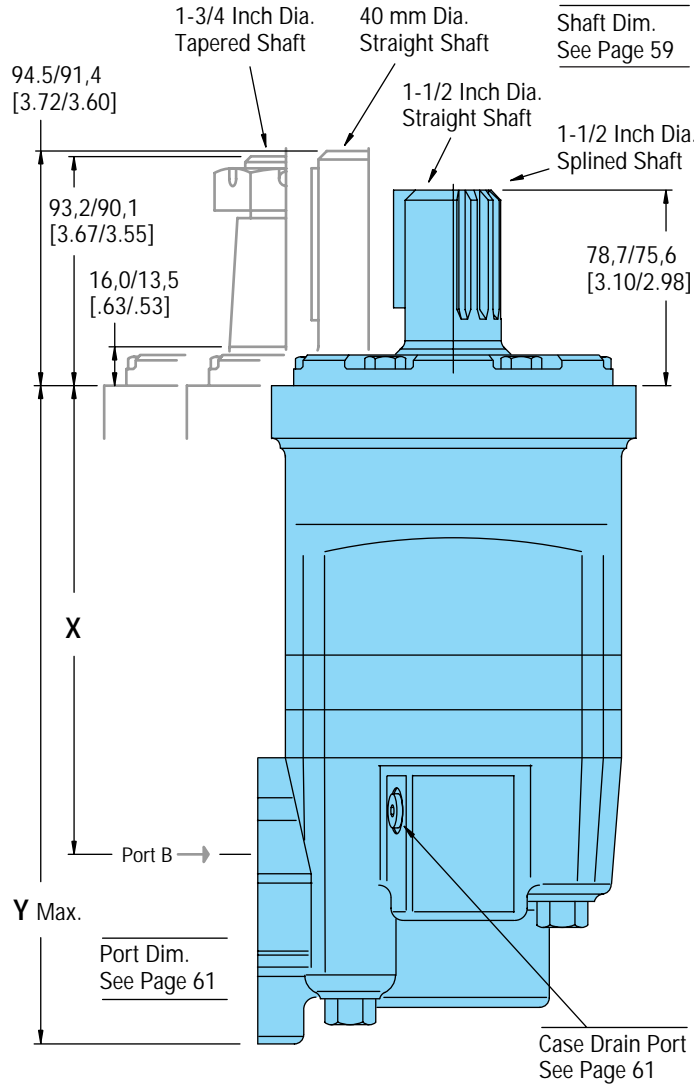

Standard Rotation
Viewed from Shaft End
Port A Pressurized — CW
Port B Pressurized — CCW

Standard SAE CC Flange

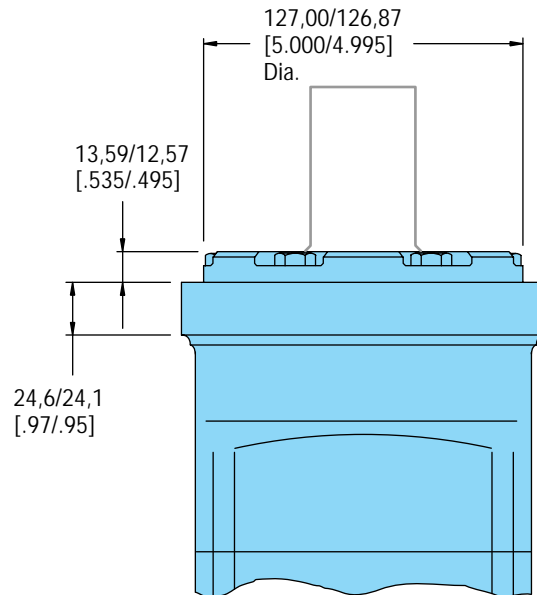
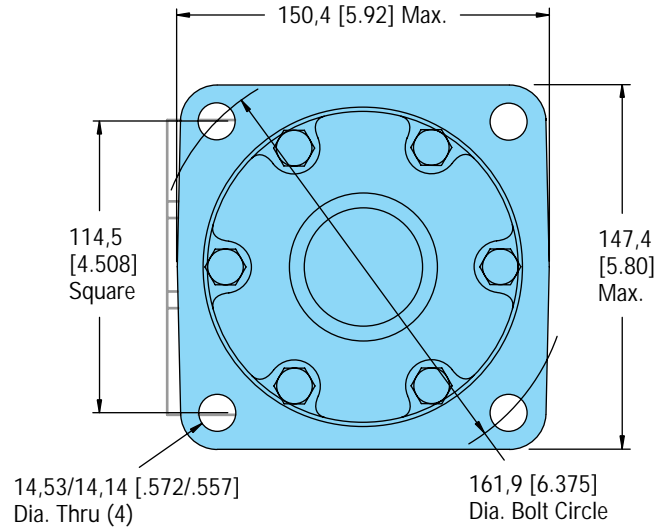

6000 Series Standard Motor with 1-5/16-12 O-ring Ports, G 1 (BSP) Ports, and 3/4 inch Split Flange Ports

Displ. cm ³ /r [in ³ /r]	195 [11.9]	245 [15.0]	310 [19.0]	390 [23.9]	490 [30.0]	625 [38.0]	985 [60.0]
X Dim. mm [inch]	187,7 [7.39]	193,3 [7.61]	200,7 [7.90]	209,3 [8.24]	220,5 [8.68]	235,2 [9.26]	274,8 [10.82]
Y Dim. mm [inch]	270,1 [10.63]	275,6 [10.85]	283,0 [11.14]	291,6 [11.48]	302,8 [11.92]	318,5 [12.54]	357,4 [14.07]

Dimensions — 6000 Series Wheel Motor

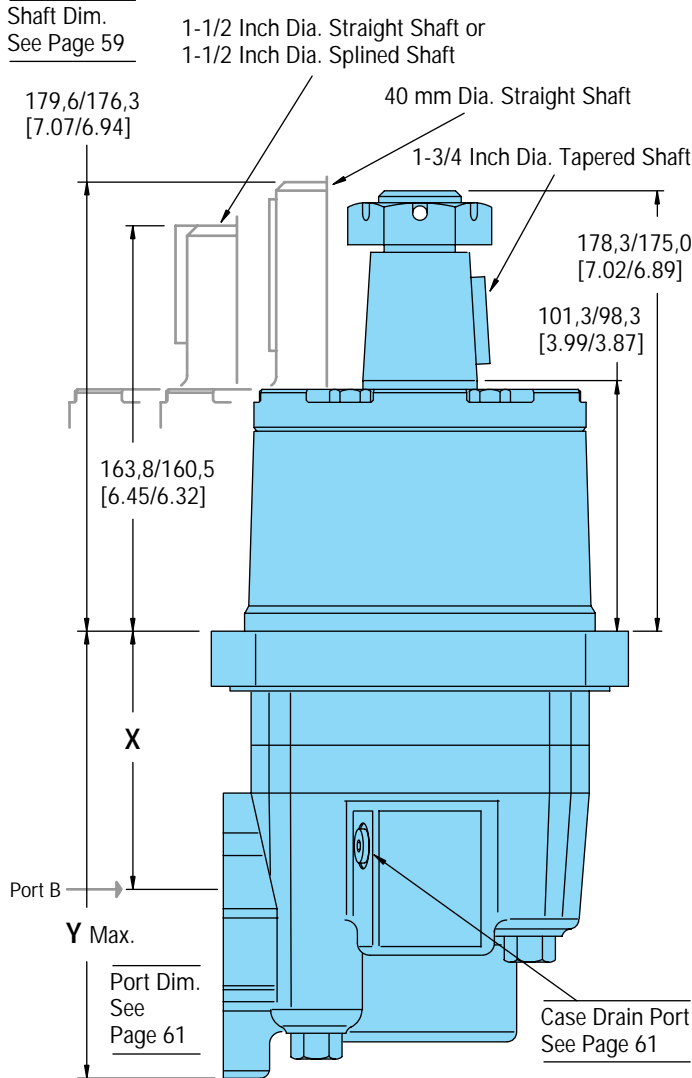

Standard Rotation
Viewed from Shaft End
Port A Pressurized — CW
Port B Pressurized — CCW

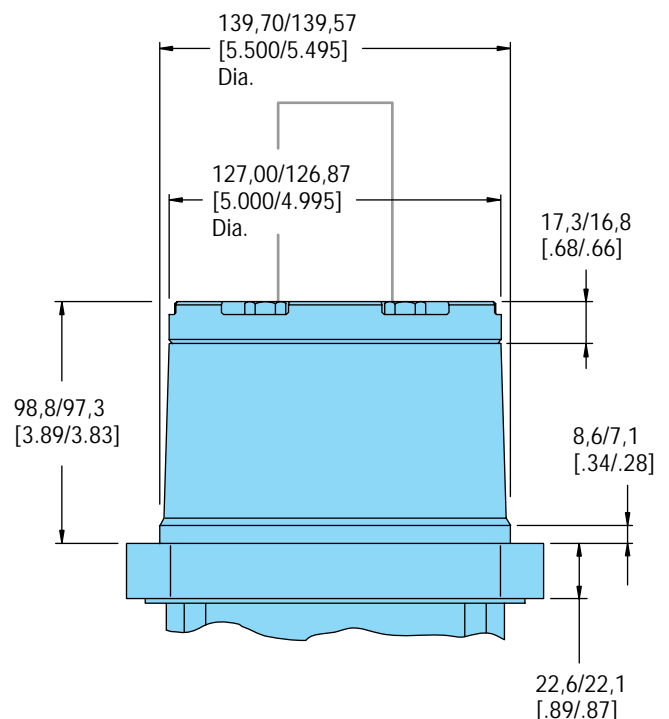
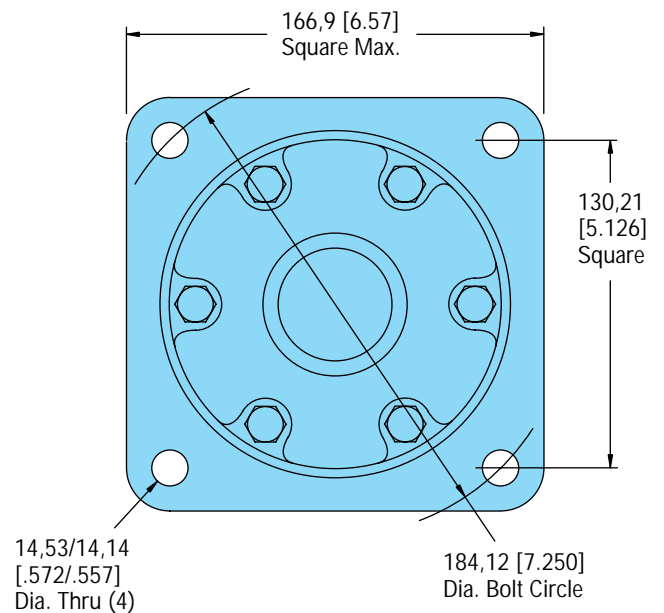

6000 Series Wheel Motor with 1-5/16-12 O-ring Ports, G 1 (BSP) Ports, and 3/4 inch Split Flange Ports

Displ. cm ³ /r [in ³ /r]	195 [11.9]	245 [15.0]	310 [19.0]	390 [23.9]	490 [30.0]	625 [38.0]	985 [60.0]
X Dim. mm [inch]	102,9 [4.05]	108,4 [4.27]	115,8 [4.56]	124,7 [4.91]	135,6 [5.34]	149,9 [5.90]	190,0 [7.48]
Y Dim. mm [inch]	185,2 [7.29]	190,8 [7.51]	198,2 [7.80]	207,1 [8.15]	218,0 [8.58]	233,0 [9.17]	272,6 [10.73]

Dimensions — 6000 Series

Global Mount

(Similar to ISO 3019/2)

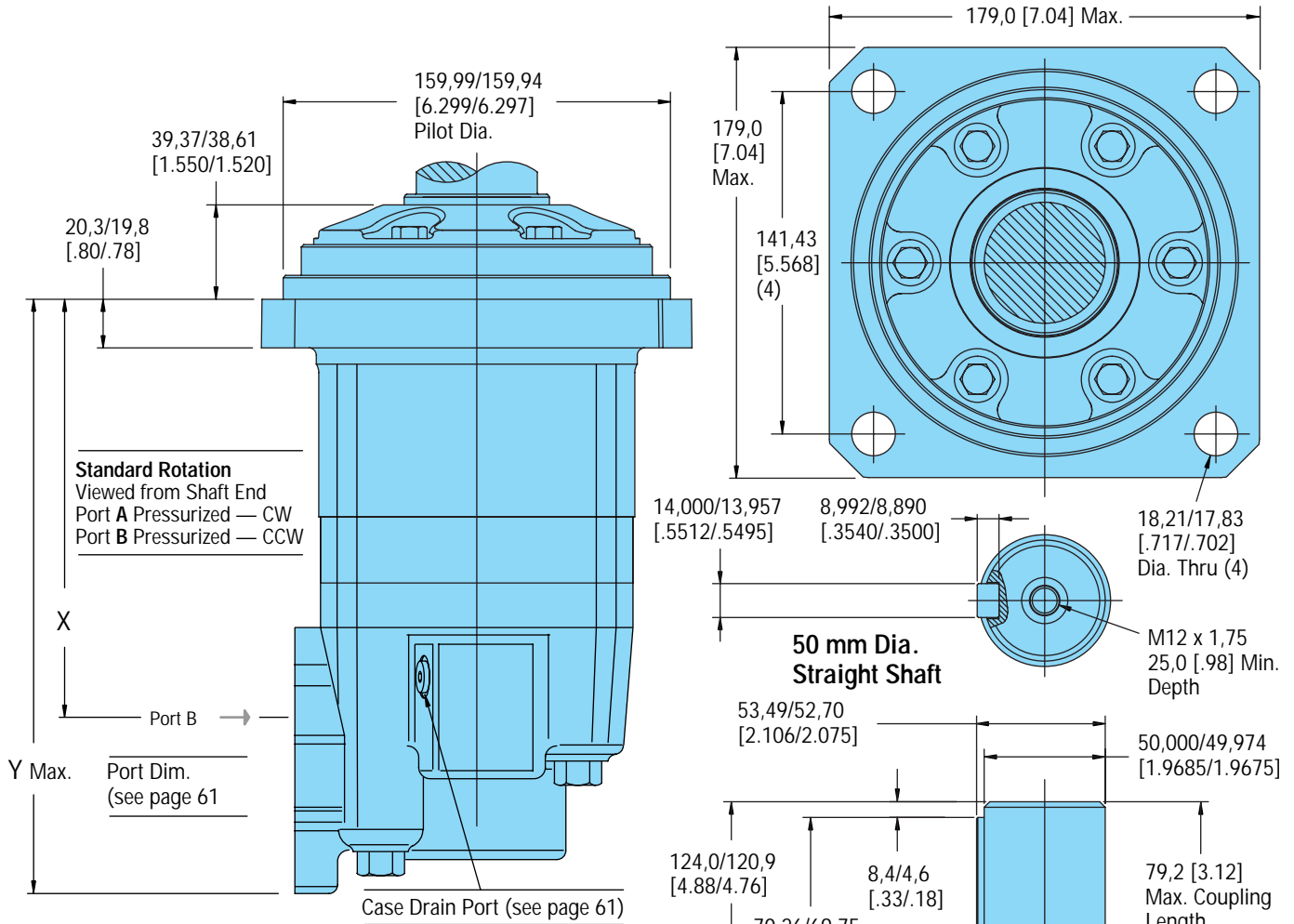

6000 Series Standard Motor with G 1 (BSP) Ports

Displ. cm ³ /r [in ³ /r]	310 [19.0]	390 [24.0]	490 [30.0]	625 [38.0]	800 [45.0]	800 [49.0]	985 [60.0]
X Dim. mm [inch]	182,4 [7.18]	191,0 [7.52]	202,2 [7.96]	216,7 [8.54]	229,4 [9.03]	236,7 [9.32]	256,5 [10.10]
Y Dim. mm [inch]	262,6 [10.34]	271,5 [10.69]	282,4 [11.12]	297,2 [11.70]	309,6 [12.19]	317,0 [12.48]	337,0 [13.27]

Dimensions — 6000 Series Bearingless Motor

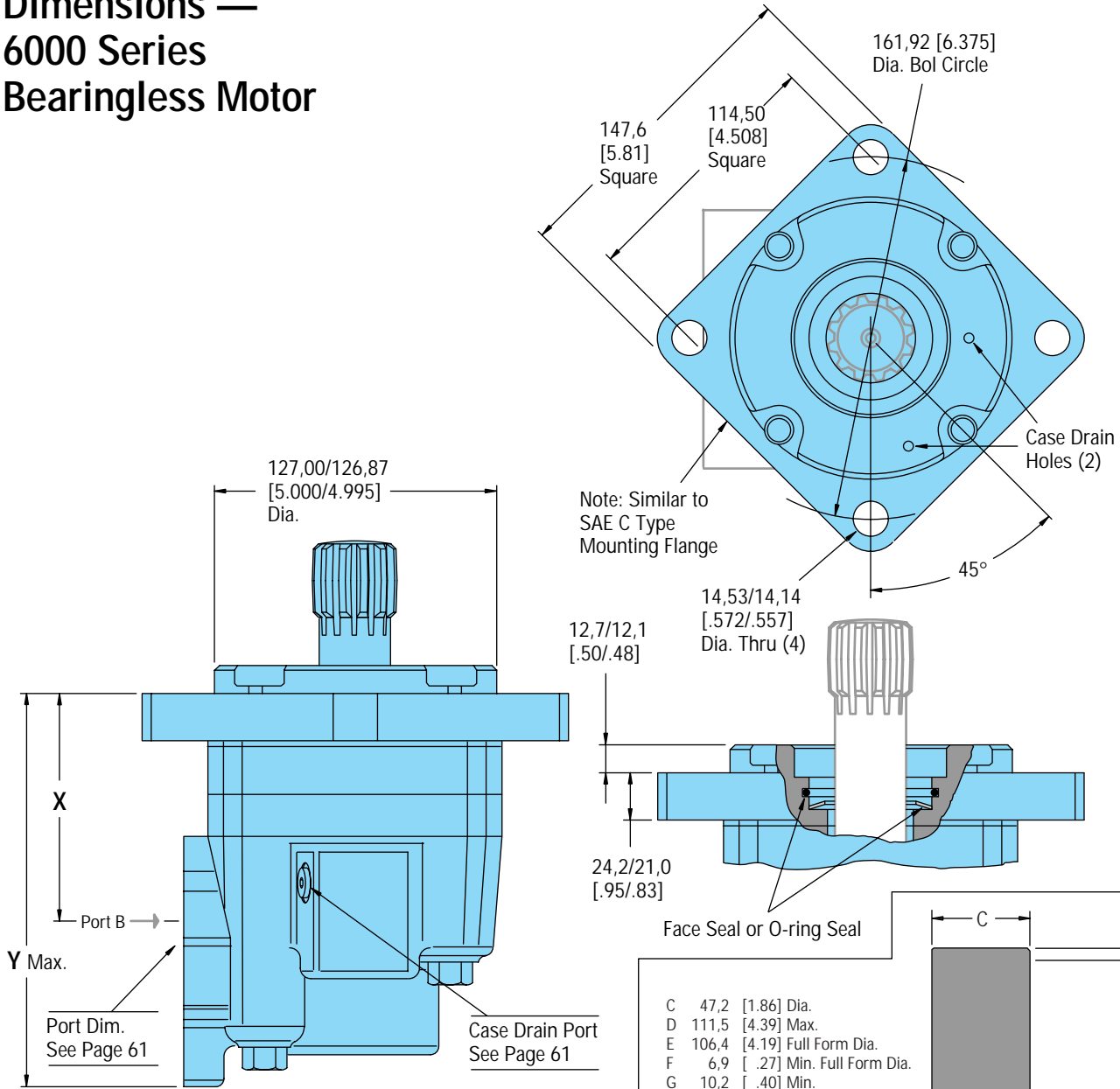

Standard Rotation
Viewed from Drive End
Port A Pressurized — CW
Port B Pressurized — CCW

6000 Series Bearingless Motor with 1-5/16-12 O-ring Ports,
G 1 (BSP) Ports, 3/4 inch Split Flange Ports

Displ. cm ³ /r [in ³ /r]	195 [11.9]	245 [15.0]	310 [19.0]	390 [23.9]	490 [30.0]	625 [38.0]	985 [60.0]
X Dim. mm [inch]	105,7 [4.16]	111,2 [4.38]	118,3 [4.66]	127,5 [5.02]	138,7 [5.46]	152,9 [6.02]	193,0 [7.60]
Y Dim. mm [inch]	188,0 [7.40]	193,6 [7.62]	200,7 [7.90]	209,6 [8.25]	220,8 [8.69]	235,5 [9.27]	275,1 [10.83]

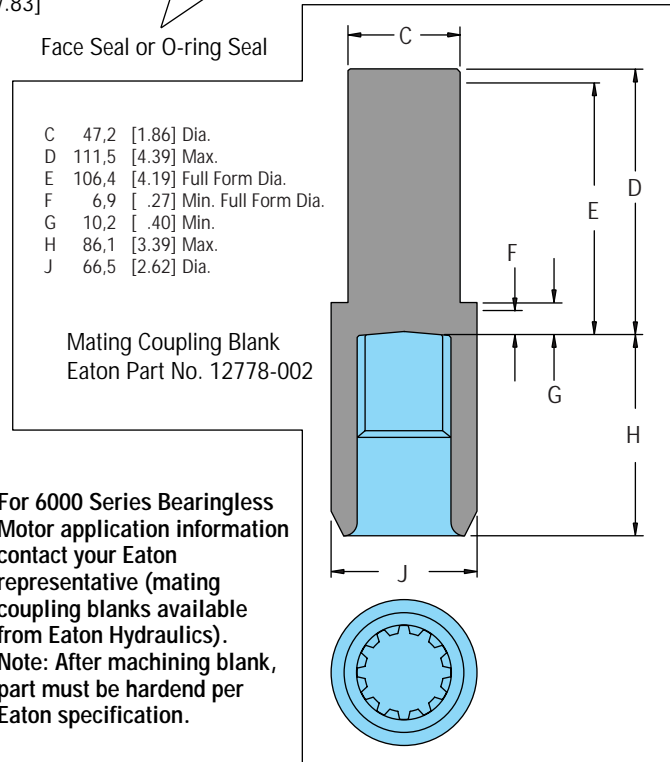

Bearingless Installation — 6000 Series

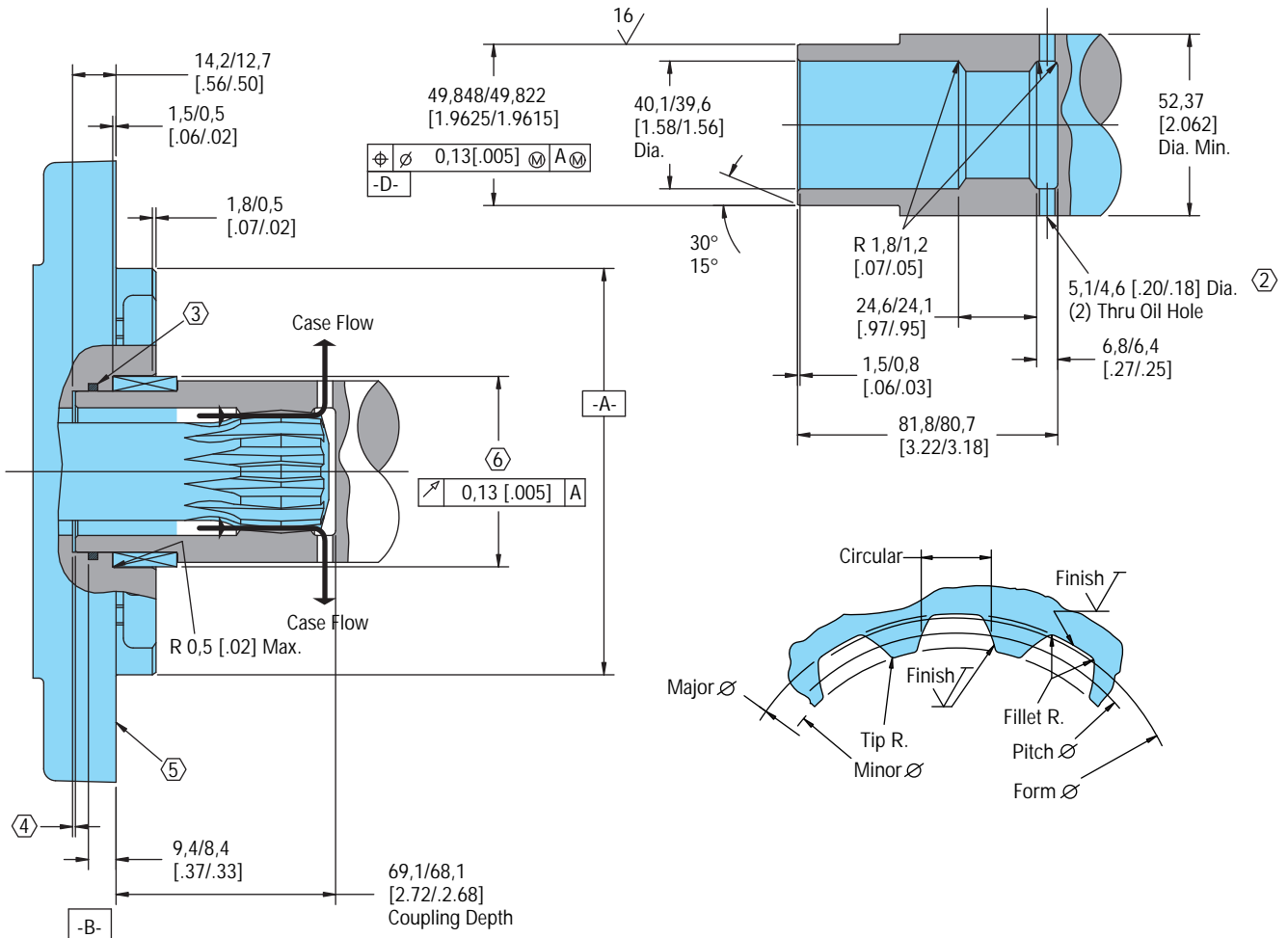

Spline Pitch — 8.5/17
 Pressure Angle — 30°
 Number of teeth — 12
 Class of Fit — Ref. 5
 Type of Fit — Side
 Pitch Diameter — Ref. 35,858823 [1.4117647] $\text{Ⓢ} 0,20 [0.008] H$
 Base Diameter — Ref. 31,054652 [1.2226241]
 Major Diameter — 39,17 [1.542] Max. 38,97 [1.534] Min.
 Minor Diameter — 33,30 - 33,48 [1.311 - 1.318]
 Form Diameter, Min. — 38,33 [1.509]
 Fillet Radius — 0,64 - 0,76 [0.025 - .030]
 Tip Radius — 0,25 - 0,51 [0.010 - .020]
 Finish — 1,6 [63]
 Involute Profile Variation — +0,000 -0,025 [+0.0000 - .0010]
 Total Index Variation — 0,038 [0.0015]
 Lead Variation — 0,013 [0.0005]
 Circular Space Width:
 Maximum Actual — 5,898 [0.2322]
 Minimum Effective — 5,804 [0.2285]
 Maximum Effective — Ref. 5,857 [0.2306]
 Minimum Actual — Ref. 5,834 [0.2297]
 Dimension Between Two Pins — Ref. 26,929 - 27,084 [1.0602 - 1.0663]
 Pin Diameter — 6,223 [0.2450] Pins to Have 4,0 [0.160] Wide Flat for Root Clearance

- 1 Internal spline in mating part to be as follows:
 Material to be ASTM A304, 8620H.
 Carborize to a hardness of 60-64 HRC with case depth (to 50HRC) of 0,076 - 1,02 [0.030 - .040] (dimensions apply after heat treat).
- 2 Mating part to have critical dimensions as shown. Oil holes must be provided and open for proper oil circulation.
- 3 Some means of maintaining clearance between shaft and mounting flange must be provided.
- 4 Seal to be furnished with motor for proper oil circulation thru splines.
- 5 Similar to SAE "C" Four Bolt Flange.
- 6 Counterbore designed to adapt to a standard sleeve bearing 50,010 - 50,038 [1.9689 - 1.9700] ID by 60,051 - 60,079 [2.3642 - 2.3653] O.D. (Oilite bronze sleeve bearing).

Dimensions — Shafts

6000 Series

78,6/75,8 [3.10/2.98] End of Shaft to Mounting Surface (Std)

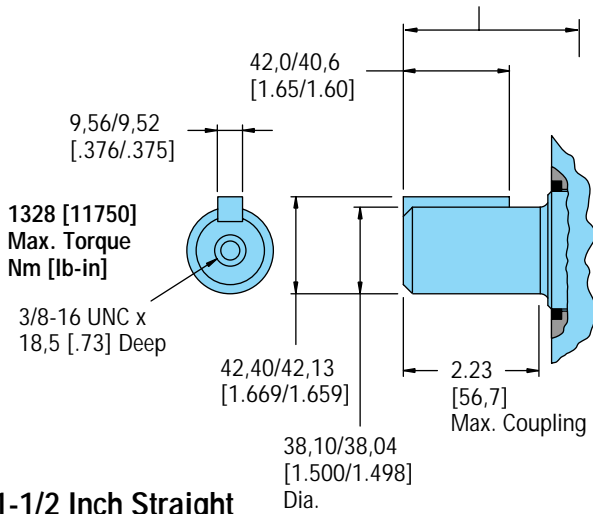

1-1/2 Inch Straight

178,1/175,0 [7.02/6.89] End of Shaft to Mounting Surface (Whl)

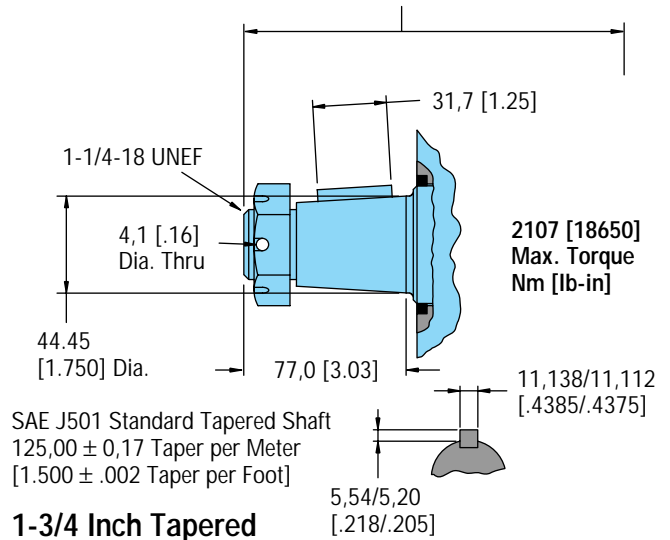

1-3/4 Inch Tapered

78,6/75,8 [3.10/2.98] End of Shaft to Mounting Surface (Std)

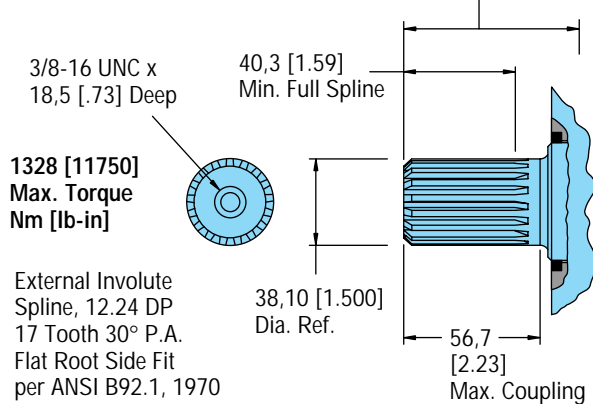

1-1/2 Inch 17 Tooth Splined

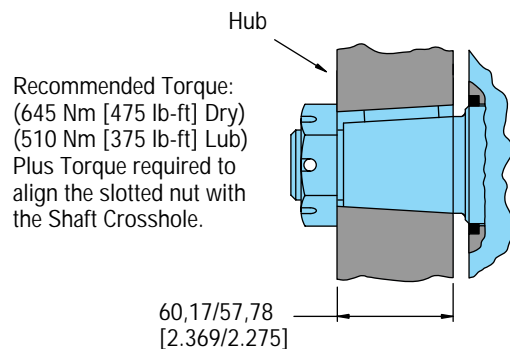

Tapered Shaft Hub Data

94,4/91,6 [3.72/3.60] End of Shaft to Mounting Surface (Std)

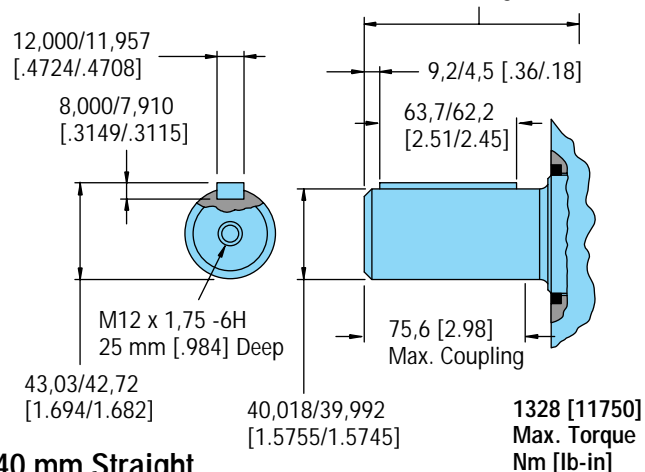

40 mm Straight

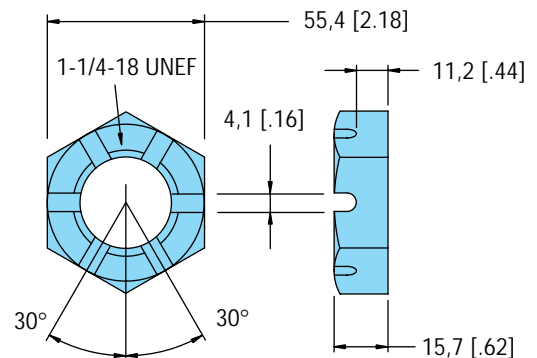

Slotted Hexagon Nut

Shaft Side Load Capacity 6000 Series

These curves indicate the radial load capacity on the motor shaft(s) at various locations.

The curve is based on B 10 Bearing life (2000 hours or 12,000,000 shaft revolutions at 100 RPM) at rated output torque. To determine radial load at speeds other than 100 RPM, multiply the load values given on the bearing curve by the factors in the chart below.

RPM	Multiplication Factor
50	1.23
100	1.00
200	.81
300	.72
400	.66
500	.62
600	.58
700	.56
800	.54

For 3,000,000 Shaft revolutions or 500 hours — Increase these shaft loads 52%.

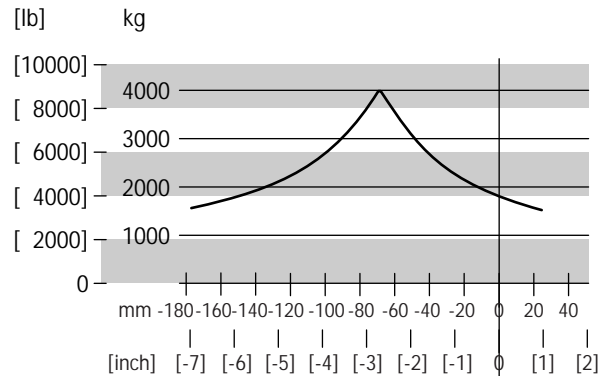

Wheel Motor
Tapered
Shaft

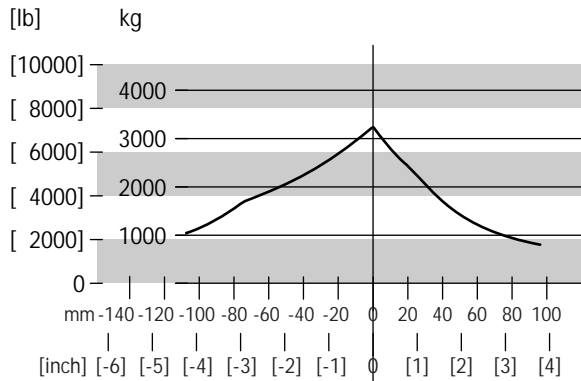
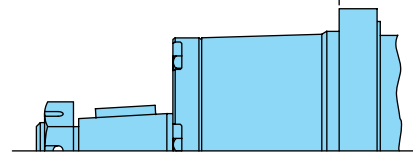

Standard Motor
Straight
Shaft

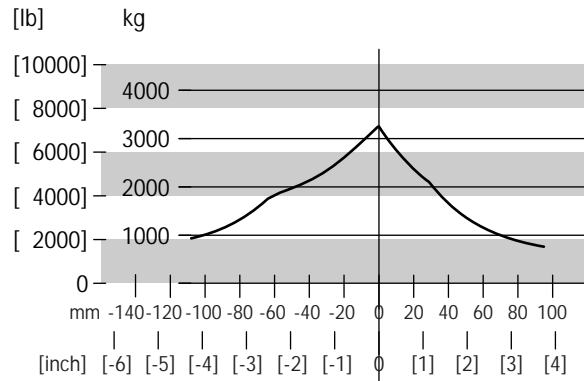
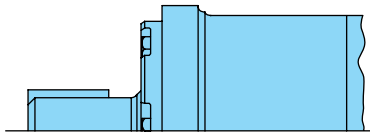

Standard Motor
Splined
Shaft

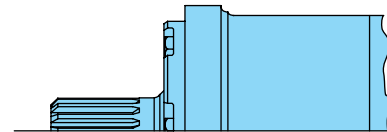

Dimensions — Ports 6000 Series

6000 Series with Shuttle Valve

1-5/16-12 O-ring Ports (2)
or G 1 (BSP) Ports (2)

7/16-20 UNF O-ring or
G 1/4 (BSP) Port
Case Drain

See Pages 54-57

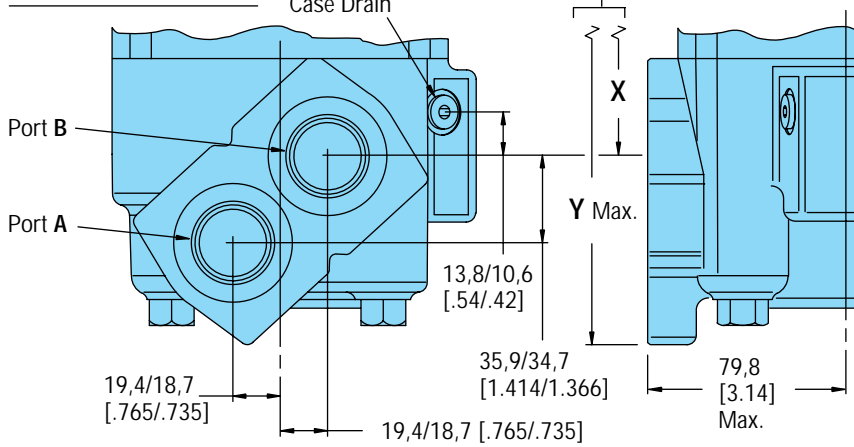

1-5/16-12 O-ring Ports (2) with Shuttle

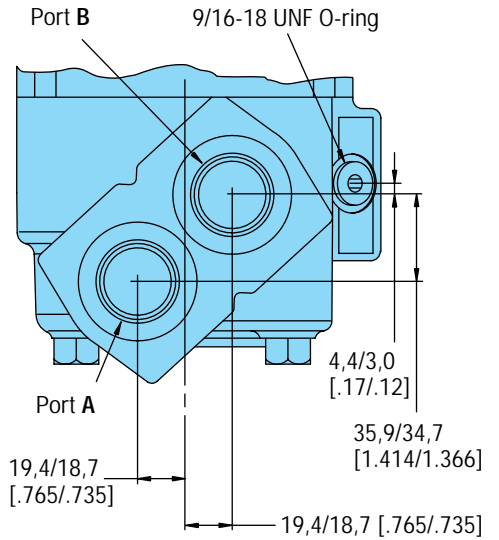

4 Bolt 3/4 Inch Split Flange
Ports to Fit SAE J518c (2)
Except for 20,0 [.79] Min. Thd. Dp.

7/16-20 UNF O-ring
Port Case Drain

See Pages 54-57

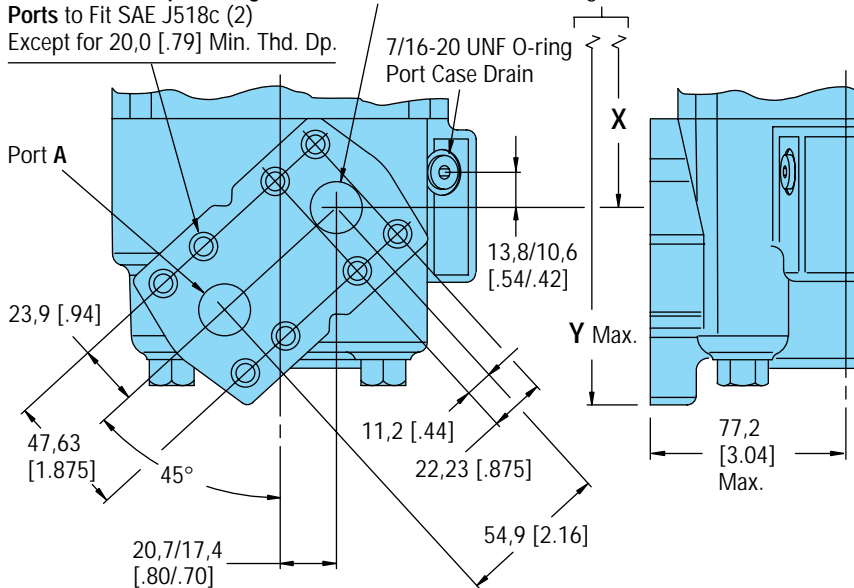

See Pages 54-57

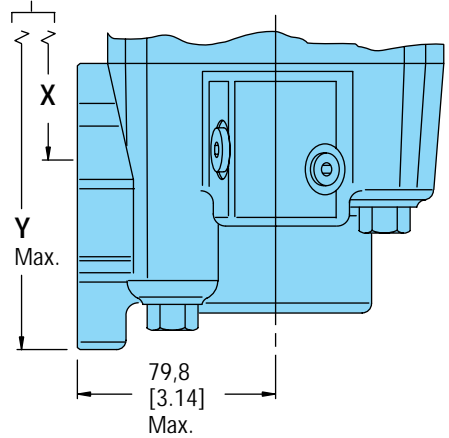

6000 Series
Motor
End View—
Common
Dim.

17°
58,0/56,3
[2.28/2.22]

Standard Rotation — 6000 Series
Viewed from Shaft End
Port A Pressurized — CW
Port B Pressurized — CCW

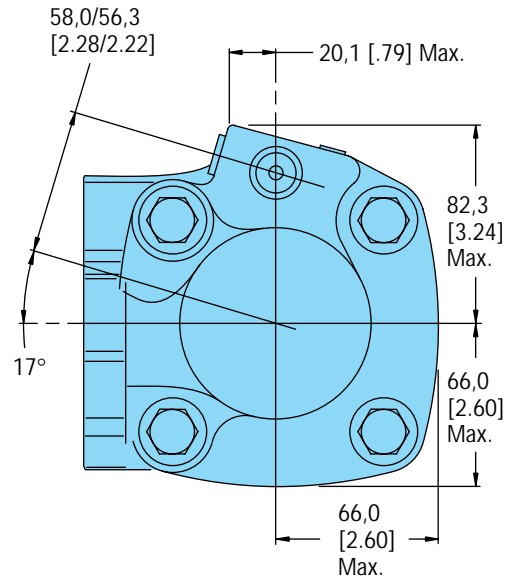
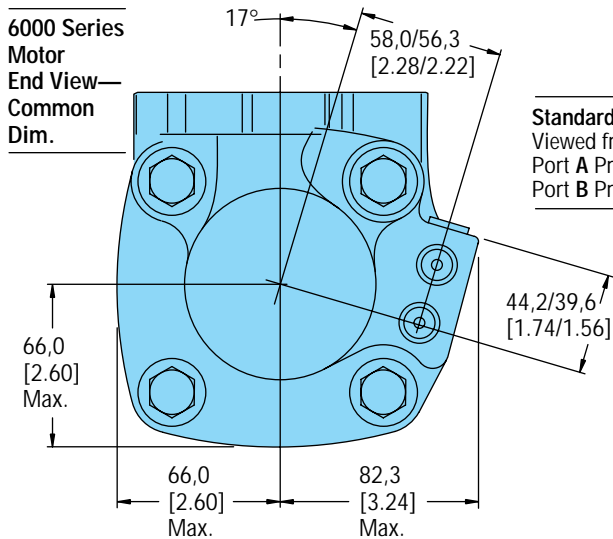

Product Numbers 6000 Series

Product Numbers—6000 Series Motors

Use digit prefix —112-, 113-, or 114- plus four digit number from charts for complete product number—Example 114-1047.
Orders will not be accepted without three digit prefix.

Mounting	Shaft	Ports	Displacement cm ³ /r [in ³ /r] and Product Number						
			195 [11.9]	245 [15.0]	310 [19.0]	390 [23.9]	490 [30.0]	625 [38.0]	985 [60.0]
Standard	1-1/2 Inch Straight	1-5/16 O-ring	112-1064	-1065	-1066	-1067	-1068	-1107	-1069
	40 mm Straight	G 1 (BSP)	112-1094	-1095	-1096	-1097	-1098	—	-1099
	1-1/2 Inch 17 T Splined	1-5/16 O-ring	112-1058	-1059	-1060	-1061	-1062	-1109	-1063
		G 1 (BSP)	112-1088	-1089	-1090	-1091	-1092	—	-1093
Wheel Motor	40 mm Straight	G 1 (BSP)	113-1082	-1083	-1084	-1085	-1086	-1100	-1087
	1-3/4 Inch Tapered	1-5/16 O-ring	113-1070	-1071	-1072	-1073	-1074	-1093	-1075
Bearingless		1-5/16 O-ring	114-1031	-1032	-1033	-1034	-1035	-1055	-1036
		G 1 (BSP)	114-1043	-1044	-1045	-1046	-1047	—	-1048

114-1047

Product Numbers – 6000 Series

Mounting Type - Standard (Code H), 4 Bolt:

- 160,0 [6.30] Pilot Dia.
- 18,01 [.709] Dia. Mounting Holes
- 200,0 [7.87] Dia. Bolt Circle

Output Shaft - Straight (Code 21)

Ports - G1 (BSP) Staggered G 1/4 Case Drain (Code C)

Paint - Low Gloss Black (Code A)

Use digit prefix —112- plus four digit number from charts for complete product number—Example 112-1215.
Orders will not be accepted without three digit prefix.

112-1215

Mounting	Shaft	Ports	Displacement cm ³ /r [in ³ /r] and Product Number						
			310 [19.0]	390 [23.9]	490 [30.0]	625 [38.0]	737 [45.0]	800 [49.0]	985 [60.0]
Standard	50 mm Straight	G 1 (BSP)	112-1217	-1218	-1215	-1216	-1247	-1219	-1220

For 6000 Series Motors with a configuration *Not Shown* in the charts above: Use model code number system on page 63 to specify product in detail.

Model Code for 6000 Series Motors

The following 14-digit coding system has been developed to identify all of the configuration options for the 6000 Series Motor. Use this model code to specify a motor with the desired features. All 14-digits of the code must be present when ordering. You may want to photocopy the matrix below to ensure that each number is entered in the correct box.

Model Code — 6000 Series Disc Valve Motors

1	2	3	4	5	6	7	8	9	10	11	12	13	14
M	0	6										0	0

Position 1 Product Series

M..... Motor

Position 2, 3 6000 Series

06..... 6000 Series

Position 4, 5 Displacement cm³/r [in³/r]

12..... 195 [11.9]

15..... 245 [15.0]

19..... 310 [19.0]

24..... 390 [23.9]

30..... 490 [30.0]

38..... 625 [38.0]

45..... 740 [45.0]*

49..... 805 [49.0]*

60..... 985 [60.0]

* For performance and dimension data contact your Eaton Hydraulics representative.

Position 6 Mounting Flange

A..... 4 Bolt (Bearingless 127,0 [5.00] Pilot Dia. and 14,3 [.56] Dia. Mounting Holes 161,9 [6.38] Dia. B.C.

B..... 4 Bolt (SAE CC) (Standard) 127,0 [5.00] Pilot Dia. and 14,3 [.56] Mounting Holes on 161,9 [6.38] Dia. B.C.

C..... 4 Bolt (Wheel) 139,7 [5.50] Pilot Dia. and 14,3 [.56] Dia. Mounting Holes on 184,1 [7.25] Dia. B.C.

H..... 4 Bolt (Global) (Standard) 160,0 [6.30] Pilot Dia. and 18,0 [.709] Dia. Mounting Holes on 200,0 [7.87] Dia. Bolt Circle

Position 7, 8 Output Shaft

00..... Bearingless

01..... 1-1/2 inch Dia. Straight with Straight Key, 3/8-16 Threaded Hole and 56,7 [2.23] Max. Coupling Length

02..... 1-3/4 inch Dia. Tapered with Straight Key and 1-1/4 - 18 UNEF Slotted Hex. Nut

03..... 1-1/2 inch Dia. Splined 17T with 40,3 [1.59] Min. Full Spline Length and 3/8-16 Threaded Hole

10..... 40 mm Dia. Straight with Straight Key, M12 x 1,75-6H Threaded Hole

21..... 50 mm Dia. Straight with Straight Key, 14W x 9H x 70L, M12 x 1,75-6H Thread in End (Available with Mounting Flange Code H Only)

24..... 60 mm Dia. 10:1 Tapered Shaft with M42 x 3-6H Threaded End (Available with Mounting Flange Code H Only)

25..... 2 1/8 inch Dia. Splined 16 Tooth, 55,9 mm [2.20] Min. Full Spline Length (Available with Mounting Flange Code H Only)

Position 9 Port Type

A..... 1-5/16 - 12 O-ring with 7/16-20 O-ring Case Drain and Check Valve

B..... 3/4 inch 4 Bolt Split Flange with 7/16-20 O-ring Case Drain and Check Valve

C..... G 1 (BSP) O-ring with G 1/4 (BSP) O-ring Case Drain and Check Valve

D..... 1- 5/16-12 O-ring with (2) 9/16-18 O-ring Case Drain Ports and Hot Oil Shuttle Valve

R..... 1- 5/16-12 O-ring with (2) 9/16-18 O-ring Ports for External Lubrication Circuit (both case ports must be connected)

Position 10, 11 Special Features (Hardware)

00..... None

10..... Viton Shaft Seal

07..... Viton Seals

13..... Reverse Rotation

14..... Seal Guard

21..... Speed Sensor (Std.)

Position 12 Paint/Special Packaging

0..... No Paint

A..... Painted Low Gloss Black

B..... Corrosion Protected

Position 13 Eaton Assigned Code when Applicable

0..... Assigned Code

Position 14 Eaton Assigned Design Code

0..... Assigned Design Code

Specifications 10,000 Series

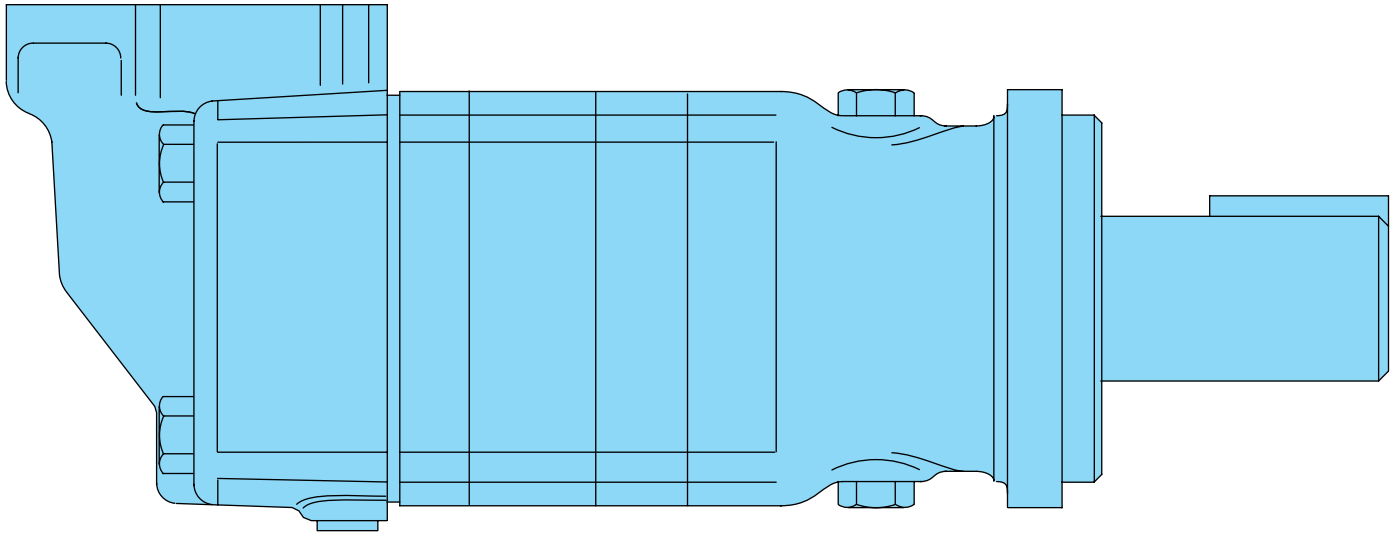

Specification Data—10,000 Series

Displ. cm ³ /r [in ³ /r]		345 [21.0]	480 [29.3]	665 [40.6]	940 [57.4]
Max. Speed (RPM) @ Flow	Continuous	501	354	254	179
	Intermittent	784	552	396	279
Flow LPM [GPM]	Continuous	170 [45]	170 [45]	170 [45]	170 [45]
	Intermittent	265 [70]	265 [70]	265 [70]	265 [70]
Torque Nm [lb-in]	Continuous	1040 [9220]	1475 [13050]	2085 [18450]	2700 [23910]
	Intermittent	1390 [12310]	1965 [17410]	2610 [23080]	3440 [30460]
Pressure Δ Bar [Δ PSI]	Continuous	205 [3000]	205 [3000]	205 [3000]	190 [2750]
	Intermittent	275 [4000]	275 [4000]	260 [3750]	240 [3500]
	Peak	275 [4000]	275 [4000]	275 [4000]	260 [3750]

Maximum Case Pressure - without Case Drain * — 20 Bar [300 PSI]

A simultaneous maximum torque and maximum speed NOT recommended. For permissible continuous and intermittent operating combinations of pressure and flow refer to performance data on pages 65-66.

* For back pressure over 20 Bar [300 PSI] use an external case drain. Install case drain lines so that the motor case remains filled at all times.

Maximum inlet pressure — 275 Bar [4000 PSI]. Do not exceed Δ pressure rating (see chart above).

* **Maximum return pressure** — 275 Bar [4000 PSI]. Do not exceed Δ pressure rating (see chart above).

Δ Bar [Δ PSI] — True pressure difference between inlet port and outlet port.

Continuous Rating — Motor may be run continuously at these ratings.

Intermittent Operation — 10% of every minute.

Peak Operation — 1% of every minute.

Recommended Fluids — Premium quality, anti-wear type hydraulic oil with a viscosity of not less than 70 SUS at operating temperature (see page 81).

Recommended Maximum System Operating Temp. — Is 82° C [180° F]

Recommended Filtration — per ISO Cleanliness Code, level 18/13

To assure best motor life, run motor for approximately one hour at 30% of rated pressure before application to full load. Be sure motor is filled with fluid prior to any load applications.

Performance Data 10,000 Series

Motors run with high efficiency in all areas designated with a number for torque and speed, however for best motor life select a motor to run with a torque and speed range shown in the light blue area.

345 cm³/r [21.0 in³/r]
Δ Pressure Bar [PSI]

480 cm³/r [29.3 in³/r]
Δ Pressure Bar [PSI]

	[250] 15	[500] 35	[1000] 70	[1500] 105	[2000] 140	[2500] 170	[3000] 205	[3500] 240	[4000] 275
[1] 3.8	[600] 70 3	[1310] 150 1							
[2] 7.5	[740] 85 21	[1510] 170 19	[3050] 345 15	[4600] 520 11	[6140] 695 8	[7680] 865 4			
[4] 15	[730] 80 43	[1500] 170 41	[3040] 345 37	[4590] 520 33	[6140] 695 30	[7680] 870 26	[9220] 1040 22	[10770] 1215 18	[12310] 1390 14
[8] 30	[720] 80 87	[1490] 170 86	[3030] 340 82	[4580] 515 74	[6120] 690 70	[7670] 865 70	[9210] 1040 66	[10750] 1215 62	[12300] 1390 58
[12] 45	[700] 80 131	[1470] 165 129	[3020] 340 127	[4560] 515 123	[6100] 690 118	[7650] 865 114	[9190] 1040 110	[10740] 1215 106	[12280] 1385 102
[16] 61	[680] 75 175	[1450] 165 174	[3000] 340 172	[4540] 515 167	[6080] 685 163	[7630] 860 158	[9170] 1035 154	[10720] 1210 149	[12260] 1385 145
[20] 76	[660] 75 219	[1430] 160 218	[2970] 335 217	[4520] 510 212	[6060] 685 207	[7600] 860 202	[9150] 1035 198	[10690] 1210 193	[12230] 1380 189
[24] 91	[630] 70 263	[1400] 160 262	[2950] 335 261	[4490] 505 256	[6030] 680 252	[7580] 855 246	[9120] 1030 242	[10660] 1205 237	[12210] 1380 232
[28] 106	[600] 70 307	[1370] 155 306	[2920] 330 305	[4460] 505 301	[6000] 680 296	[7550] 855 291	[9090] 1025 286	[10640] 1200 280	[12180] 1375 275
[32] 121	[570] 65 351	[1340] 150 350	[2890] 325 349	[4430] 500 345	[5970] 675 340	[7520] 850 335	[9060] 1025 329	[10610] 1200 324	[12150] 1370 319
[36] 136	[540] 60 395	[1310] 150 394	[2850] 320 393	[4400] 495 388	[5940] 670 384	[7480] 845 379	[9030] 1020 373	[10570] 1195 368	[12120] 1370 362
[40] 151	[500] 55 439	[1270] 145 438	[2820] 320 437	[4360] 495 433	[5910] 670 429	[7450] 840 423	[8990] 1015 417	[10540] 1190 412	
[45] 170	[460] 50 494	[1220] 140 493	[2760] 310 492	[4300] 485 490	[5840] 660 486	[7380] 835 480	[8910] 1005 473	[10450] 1180 467	
[60] 227		[1080] 130 659	[2620] 295 658	[4160] 470 655	[5710] 645 651	[7250] 820 644	[8800] 995 637		
[70] 265		[960] 110 769	[2510] 285 768	[4050] 460 765	[5590] 630 761	[7140] 805 754	[8680] 980 746		

	[250] 15	[500] 35	[1000] 70	[1500] 105	[2000] 140	[2500] 170	[3000] 205	[3500] 240	[4000] 275
[1] 3.8	[760] 85 6	[1540] 175 5	[3120] 355 4	[4640] 525 2					
[2] 7.5	[1040] 120 15	[2140] 240 13	[4320] 490 11	[6500] 735 8	[8690] 980 5	[10870] 1230 2			
[4] 15	[1040] 120 31	[2130] 240 29	[4310] 485 27	[6490] 735 24	[8680] 980 21	[10860] 1225 18	[13050] 1475 16	[15230] 1720 13	[17410] 1965 10
[8] 30	[1020] 115 87	[2110] 240 86	[4290] 485 82	[6480] 730 74	[8680] 980 53	[10840] 1225 50	[13030] 1470 47	[15210] 1720 44	[17390] 1965 42
[12] 45	[990] 110 94	[2080] 235 93	[4270] 480 90	[6450] 730 87	[8660] 975 81	[10820] 1220 81	[13000] 1470 78	[15180] 1715 75	[17370] 1965 73
[16] 61	[960] 110 125	[2060] 235 124	[4240] 480 122	[6420] 725 119	[8600] 970 116	[10790] 1220 113	[12970] 1465 110	[15150] 1710 107	[17340] 1960 104
[20] 76	[930] 105 156	[2020] 230 155	[4200] 475 154	[6390] 720 150	[8570] 970 147	[10750] 1215 144	[12940] 1460 141	[15120] 1710 138	[17300] 1955 135
[24] 91	[890] 100 188	[1980] 225 187	[4170] 470 185	[6350] 715 182	[8530] 965 179	[10720] 1210 175	[12900] 1460 172	[15080] 1705 169	
[28] 106	[850] 95 220	[1940] 220 219	[4130] 465 217	[6310] 715 214	[8490] 960 210	[10680] 1205 207	[12860] 1455 203	[15040] 1700 200	
[32] 121	[810] 90 251	[1900] 215 250	[4080] 460 249	[6270] 710 245	[8450] 955 242	[10630] 1200 238	[12820] 1450 235	[15000] 1695 231	
[36] 136	[760] 85 283	[1850] 210 282	[4040] 455 280	[6220] 705 277	[8400] 950 273	[10590] 1195 270	[12770] 1445 266		
[40] 151	[710] 80 314	[1800] 205 313	[3990] 450 312	[6170] 695 308	[8350] 945 305	[10540] 1190 301	[12720] 1440 297		
[45] 170	[647] 75 354	[1740] 195 353	[3920] 445 351	[6110] 690 348	[8290] 935 344	[10470] 1185 340	[12660] 1430 336		
[60] 227		[430] 50 472	[1520] 170 471	[3710] 420 469	[5890] 665 467	[8070] 910 462	[10260] 1160 458	[12440] 1405 454	
[70] 265			[1360] 155 551	[3540] 400 550	[5730] 645 546	[7910] 895 541	[10100] 1140 536	[12280] 1385 532	

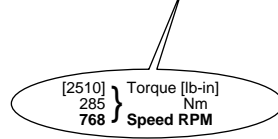

Light blue: Continuous
Dark blue: Intermittent

Performance data is typical at 120 SUS. Actual data may vary slightly from unit to unit in production

665 cm³/r [40.6 in³/r]
 Δ Pressure Bar [PSI]

Performance Data 10,000 Series

	[250] 15	[500] 35	[750] 50	[1000] 70	[1250] 85	[1500] 105	[1750] 120	[2000] 140	[2250] 155	[2500] 170	[2750] 190	[3000] 205	[3250] 225	[3500] 240	[3750] 260
[1] 3.8	[1470] 165 4	[3010] 340 3	[4550] 515 3	[6100] 690 2	[7630] 860 1										
[2] 7.5	[1480] 165 10	[3020] 340 9	[4560] 515 8	[6110] 690 7	[7650] 865 7	[9200] 1040 6	[10740] 1215 5	[12280] 1385 4	[13830] 1565 3	[15370] 1735 2	[16910] 1910 1				
[4] 15	[1470] 165 22	[3010] 340 21	[4550] 515 20	[6100] 690 19	[7640] 865 18	[9190] 1040 17	[10730] 1210 16	[12270] 1385 15	[13820] 1560 14	[15360] 1735 13	[16900] 1910 12	[18450] 2085 11	[19900] 2260 10	[21540] 2435 9	[23080] 2610 8
[8] 30	[1440] 165 44	[2980] 335 43	[4530] 510 42	[6070] 685 41	[7610] 860 40	[9160] 1035 39	[10700] 1210 38	[12250] 1385 37	[13790] 1560 36	[15330] 1730 35	[16880] 1905 34	[18420] 2080 33	[19960] 2255 32	[21510] 2430 32	[23050] 2605 31
[12] 45	[1400] 160 67	[2950] 335 66	[4490] 505 65	[6040] 680 64	[7580] 855 63	[9120] 1030 62	[10670] 1205 61	[12210] 1380 60	[13750] 1555 59	[15300] 1730 58	[16840] 1905 57	[18380] 2075 56	[19930] 2255 55	[21470] 2425 54	[23020] 2600 53
[16] 61	[1360] 155 89	[2910] 330 88	[4450] 505 87	[5990] 675 86	[7540] 850 85	[9080] 1025 84	[10620] 1200 83	[12170] 1375 82	[13710] 1550 81	[15260] 1725 80	[16800] 1900 79	[18340] 2070 78	[19890] 2245 77	[21430] 2420 76	
[20] 76	[1310] 150 112	[2860] 310 111	[4400] 495 110	[5940] 670 109	[7490] 845 108	[9030] 1020 107	[10580] 1195 106	[12120] 1370 105	[13660] 1545 104	[15210] 1720 103	[16750] 1890 102	[18300] 2070 101	[19840] 2240 100		
[24] 91	[1260] 140 135	[2800] 315 134	[4350] 490 133	[5890] 665 131	[7440] 840 130	[8980] 1015 129	[10520] 1190 128	[12070] 1365 127	[13610] 1540 126	[15150] 1710 125	[16700] 1885 124	[18240] 2060 123	[19780] 2235 122		
[28] 106	[1200] 135 157	[2750] 310 156	[4290] 485 155	[5840] 660 154	[7380] 835 153	[8920] 1010 151	[10470] 1185 150	[12010] 1355 149	[13550] 1530 148	[15100] 1705 147	[16640] 1880 146				
[32] 121	[1140] 130 180	[2690] 305 179	[4230] 480 177	[5770] 650 176	[7320] 825 175	[8860] 1000 174	[10400] 1175 173	[11950] 1350 172	[13490] 1525 171	[15040] 1700 169	[16580] 1875 168				
[36] 136	[1080] 120 202	[2620] 295 201	[4160] 470 200	[5710] 645 199	[7250] 820 198	[8800] 995 196	[10340] 1170 195	[11880] 1340 194	[13430] 1515 193	[14970] 1690 191	[16510] 1865 190				
[40] 151	[1010] 115 225	[2550] 290 224	[4100] 465 222	[5640] 635 221	[7180] 810 220	[8730] 985 219	[10270] 1160 217	[11810] 1335 216	[13360] 1510 215	[14900] 1685 214	[16440] 1855 212				
[45] 170	[920] 105 254	[2460] 280 252	[4000] 450 251	[5550] 625 249	[7090] 800 248	[8630] 975 247	[10180] 1150 245	[11720] 1325 244	[13260] 1500 243	[14810] 1675 242					
[60] 227	[610] 70 338	[2150] 245 336	[3700] 420 335	[5240] 590 334	[6780] 765 332	[8330] 940 331	[9870] 1115 329	[11420] 1290 328	[12960] 1465 327						
[70] 265	[380] 45 396	[1930] 220 393	[3470] 390 391	[5010] 565 390	[6560] 740 388	[8100] 915 387	[9640] 1090 385	[11190] 1265 384							

[3470]
390
391 } Torque [lb-in]
Nm
Speed RPM

Continuous
Intermittent

940 cm³/r [57.4 in³/r]
 Δ Pressure Bar [PSI]

Motors run with high efficiency in all areas designated with a number for torque and speed, however for best motor life select a motor to run with a torque and speed range shown in the light blue area.

	[250] 15	[500] 35	[750] 50	[1000] 70	[1250] 85	[1500] 105	[1750] 120	[2000] 140	[2250] 155	[2500] 170	[2750] 190	[3000] 205	[3250] 225	[3500] 240
[1] 3.8	[2080] 235 3	[4260] 480 2	[6440] 730 1											
[2] 7.5	[2090] 235 7	[4270] 480 6	[6450] 730 5	[8640] 975 5	[10820] 1220 4	[13000] 1470 3	[15190] 1715 2	[17370] 1965 1						
[4] 15	[2080] 235 15	[4260] 480 14	[6440] 730 13	[8620] 975 13	[10810] 1220 12	[12990] 1470 11	[15170] 1715 10	[17360] 1960 9	[19540] 2170 8	[21720] 2455 7	[23910] 2700 7	[26090] 2950 6	[28270] 3195 5	[30460] 3440 4
[8] 30	[2040] 230 31	[4220] 475 30	[6400] 725 29	[8590] 970 28	[10770] 1215 28	[12950] 1465 27	[15140] 1710 26	[17320] 1955 25	[19500] 2200 24	[21690] 2450 23	[23870] 2695 22			
[12] 45	[1990] 225 47	[4170] 470 46	[6350] 715 45	[8540] 965 44	[10720] 1210 43	[12900] 1460 43	[15090] 1705 42	[17270] 1950 41	[19450] 2200 40	[21640] 2445 39				
[16] 61	[1930] 220 63	[4110] 465 62	[6290] 710 61	[8480] 960 60	[10660] 1205 59	[12840] 1450 58	[15030] 1700 58	[17210] 1945 57	[19390] 2190 56					
[20] 76	[1860] 210 79	[4040] 455 78	[6220] 705 77	[8410] 950 76	[10590] 1195 75	[12770] 1445 74	[14960] 1690 73	[17140] 1935 72	[19320] 2185 72					
[24] 91	[1780] 200 95	[3970] 450 94	[6150] 695 93	[8330] 940 92	[10520] 1190 91	[12700] 1435 90	[14880] 1680 89	[17070] 1930 88						
[28] 106	[1700] 190 111	[3890] 440 110	[6070] 685 109	[8250] 930 108	[10440] 1180 107	[12620] 1425 106	[14800] 1675 105	[16990] 1920 104						
[32] 121	[1620] 185 127	[3800] 430 126	[5980] 675 125	[8160] 920 124	[10350] 1170 123	[12530] 1415 122	[14720] 1665 121							
[36] 136	[1520] 170 143	[3710] 420 142	[5890] 665 141	[8070] 910 140	[10260] 1160 139	[12440] 1405 138	[14620] 1650 137							
[40] 151	[1420] 160 159	[3610] 410 158	[5790] 655 157	[7970] 900 156	[10160] 1150 155	[12340] 1395 154	[14520] 1640 153							
[45] 170	[1290] 145 179	[3480] 395 178	[5660] 640 177	[7840] 885 176	[10020] 1130 174	[12210] 1380 174	[14400] 1625 173							
[60] 227	[860] 95 239	[3040] 345 238	[5230] 590 236	[7410] 835 235	[9600] 1085 234	[11780] 1330 233								
[70] 265	[540] 60 279	[2720] 305 278	[4910] 555 276	[7090] 800 275	[9270] 1045 274	[11460] 1295 273								

Performance data is typical at 120 SUS. Actual data may vary slightly from unit to unit in production

Dimensions — 10,000 Series Standard Motor

Shaft Dim. See Page 71

2-1/4 Inch Dia. Straight Shaft or
2-1/4 Inch Dia. Tapered Shaft

2-1/8 Inch Dia. Splined Shaft

114,1/112,0
[4.49/4.41]

20,1/16,5
[.79/.65]

91,7/89,6
[3.61/3.53]

7/8-14 UNC
O-ring Case
Drain Port
(2)

9/16-18 UNC
O-ring Case
Drain Port

Port Dim.
See Page 73

X

Y Max.

Port B

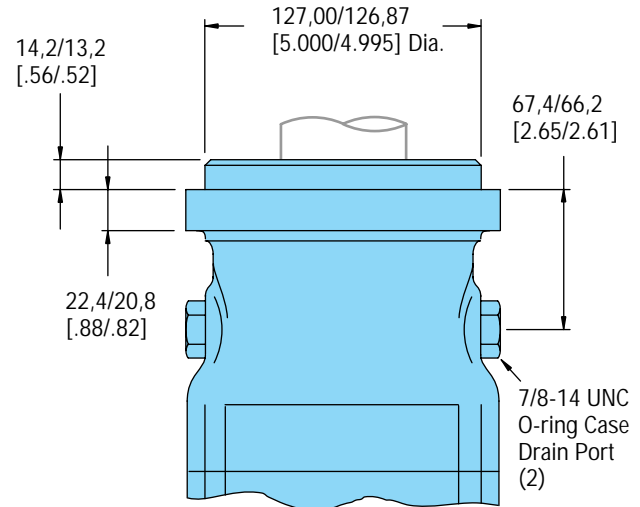
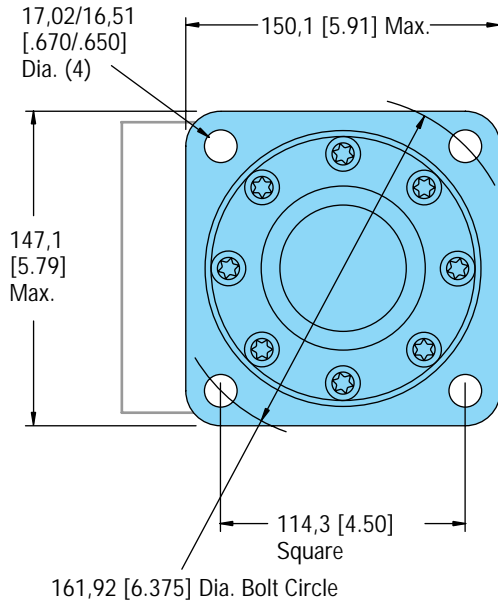

10,000 Series Standard Motor

Displ. cm ³ /r [in ³ /r]	345 [21.0]	480 [29.2]	665 [40.6]	940 [57.4]
X Dim. mm [inch]	282,4 [11.12]	295,1 [11.62]	295,1 [11.62]	313,4 [12.34]
Y Dim. mm [inch]	381,0 [15.00]	393,7 [15.50]	393,7 [15.50]	412,0 [16.22]

Standard Rotation

Viewed from Shaft End
Port A Pressurized — CW
Port B Pressurized — CCW

Dimensions — 10,000 Series Wheel Motor

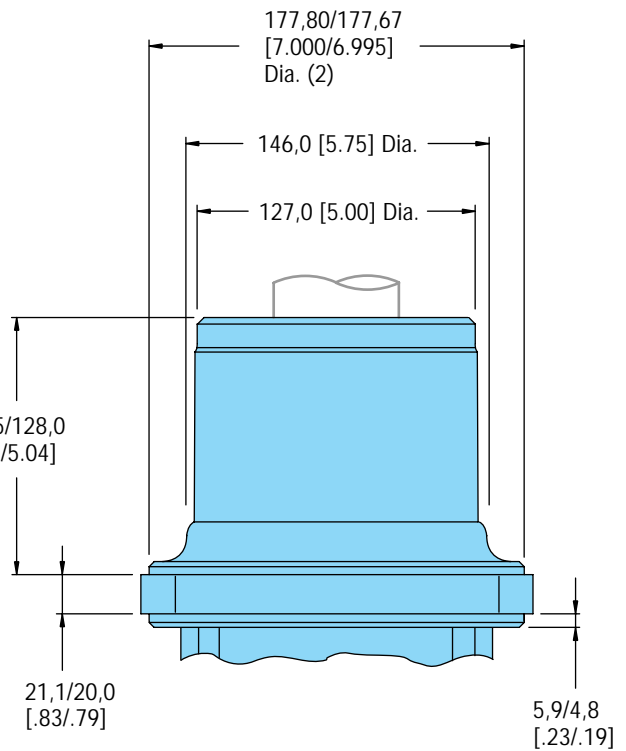
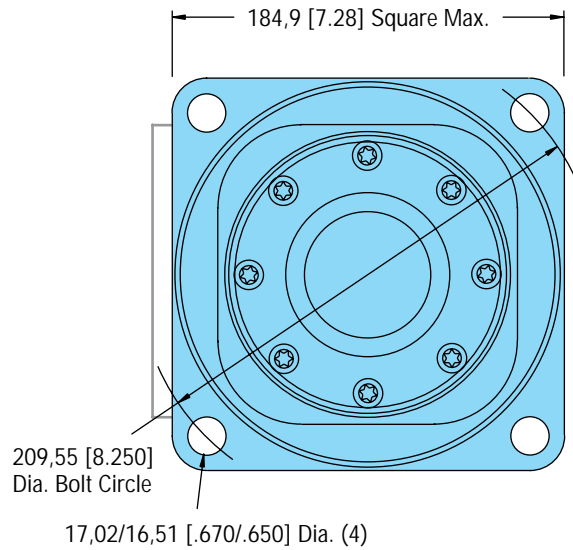
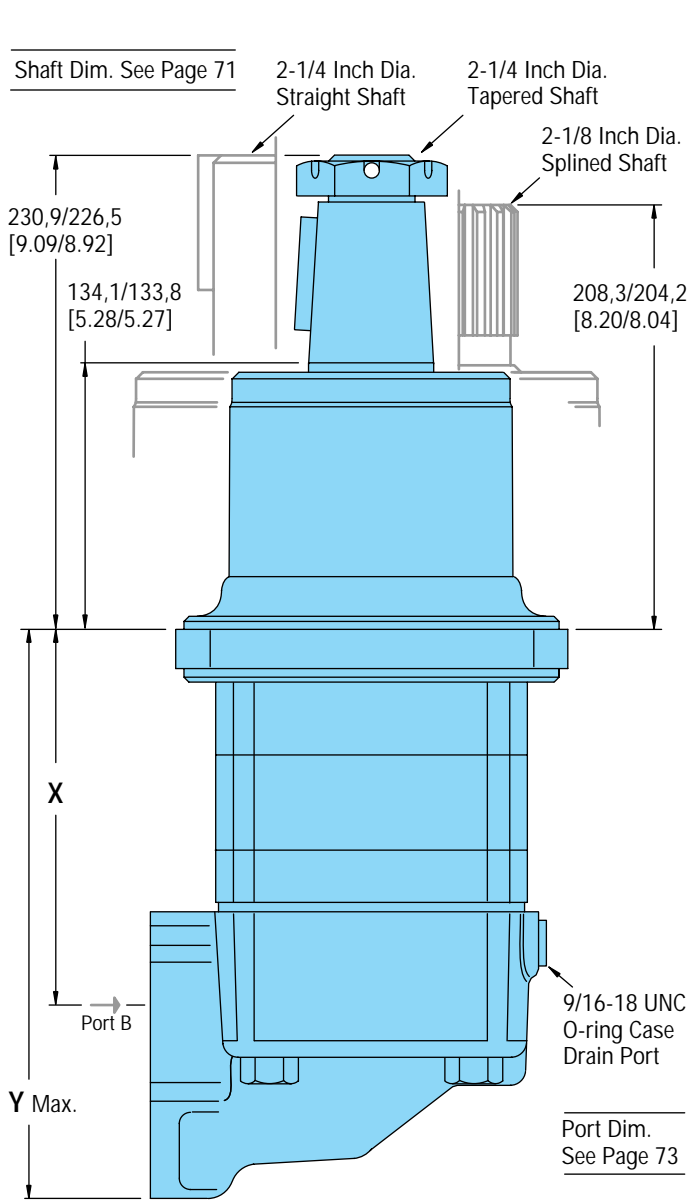

10,000 Series Wheel Motor

Displ. cm ³ /r [in ³ /r]	345 [21.0]	480 [29.2]	665 [40.6]	940 [57.4]
X Dim. mm [inch]	166,9 [6.57]	179,6 [7.07]	179,6 [7.07]	197,8 [7.79]
Y Dim. mm [inch]	266,2 [10.48]	278,9 [10.98]	278,9 [10.98]	297,5 [11.71]

Standard Rotation
Viewed from Shaft End
Port A Pressurized — CW
Port B Pressurized — CCW

Dimensions — 10,000 Series Bearingless Motor

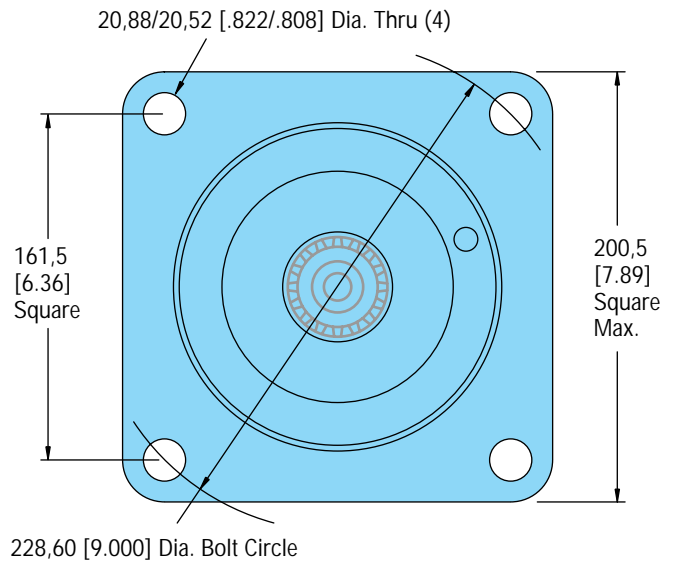

Standard Rotation
Viewed from Drive End
Port A Pressurized — CW
Port B Pressurized — CCW

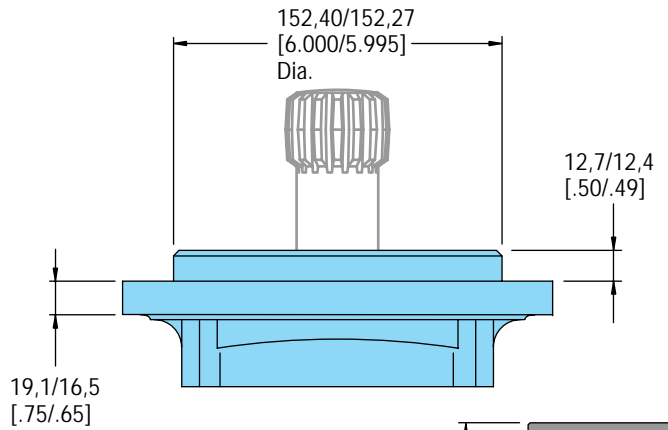
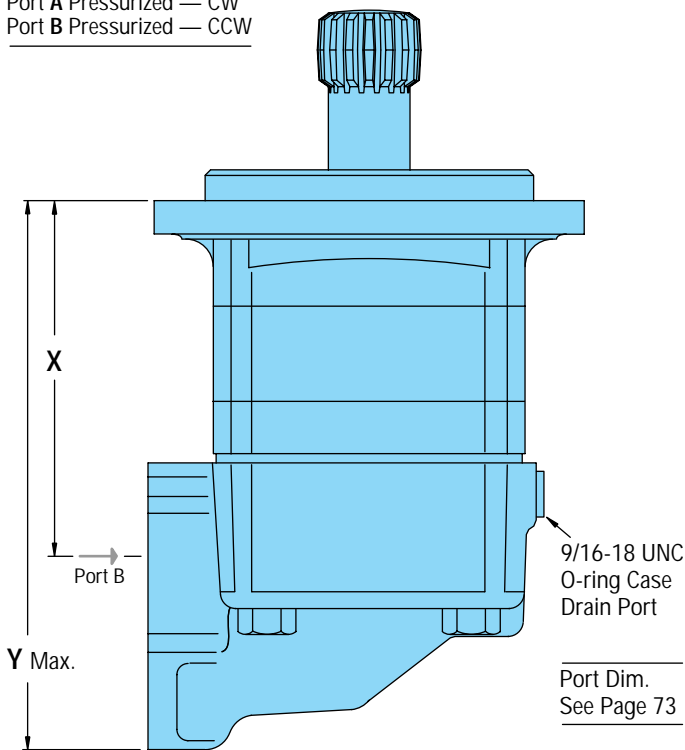

For 10,000 Series bearingless motor application information contact your Eaton representative (mating coupling blanks available from Eaton Corporation). Note: After machining blank, part must be hardened per Eaton specification.

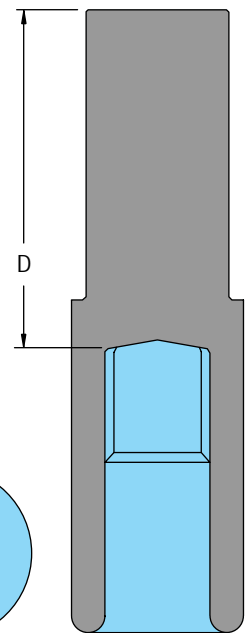

10,000 Series Bearingless Motor

Displ. cm ³ /r [in ³ /r]	345 [21.0]	480 [29.2]	665 [40.6]	940 [57.4]
X Dim. mm [inch]	189,5 [7.46]	202,2 [7.96]	202,2 [7.96]	221,0 [8.70]
Y Dim. mm [inch]	288,5 [11.36]	301,0 [11.85]	301,0 [11.85]	319,5 [12.58]

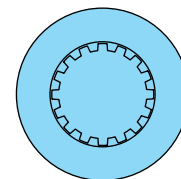

Mating Coupling Blank Eaton Part No. 13280-001	Dimension D mm [inch]
13280-001	133,6/128,5 [5.26/5.06]
13280-002	156,0/150,9 [6.14/5.94]

Bearingless Installation — 10,000 Series

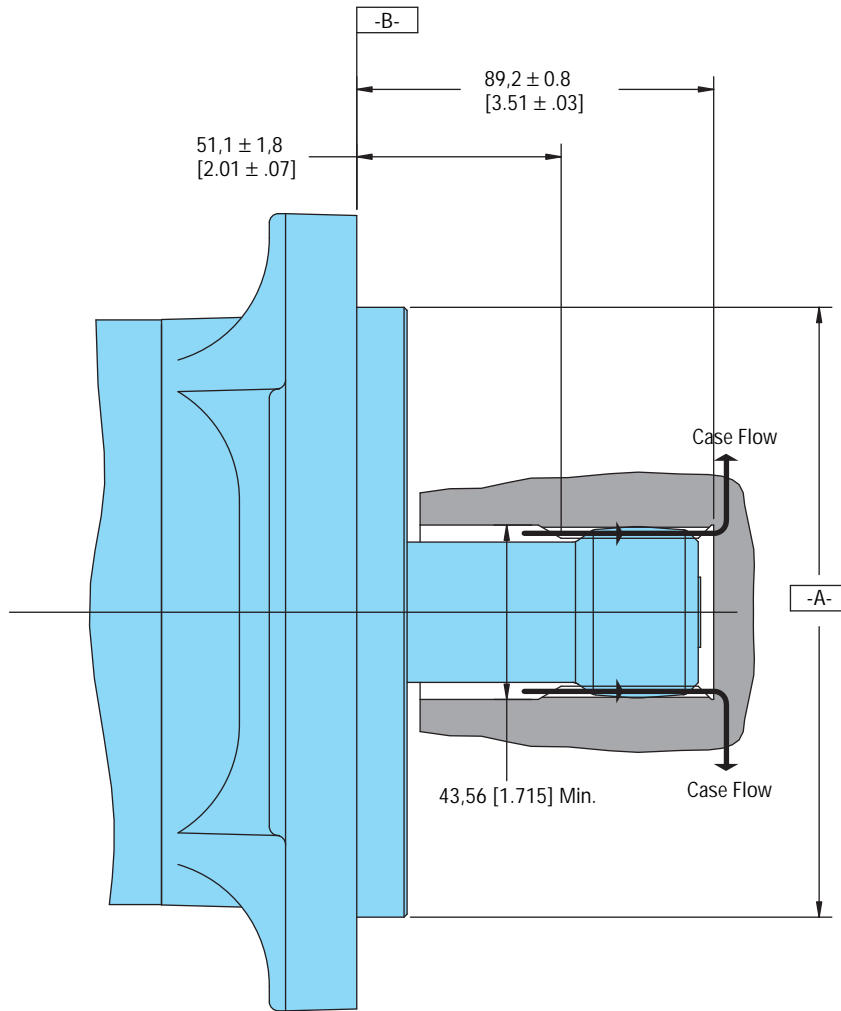

- Spline Pitch — 10/20
- Pressure Angle — 30°
- Number of teeth — 16
- Class of Fit — Ref. 5
- Type of Fit — Side
- Pitch Diameter — Ref. 40,640000 [1.600000] ◎ 0,25 [0.10] D
- Base Diameter — Ref. 35,195272 [1.3856406]
- Major Diameter — 43,56 [1.715] Max. 43,18 [1.700] Min.
- Minor Diameter — 36,83 - 37,08 [1.450 - 1.460]
- Form Diameter, Min. — 42,47 [1.672]
- Fillet Radius — 0,64 - 0,76 [.025 - .030]
- Tip Radius — 0,25 - 0,51 [.010 - .020]
- Finish — 1,6 [63]
- Involute Profile Variation — +0,000 -0,028 [+0.0000 -0.0011]
- Total Index Variation — 0,041 [.0016]
- Lead Variation — 0,013 [.0005]
- Circular Space Width:
 - Maximum Actual — 4,105 [.1616]
 - Minimum Effective — 3,995 [.1573]
 - Maximum Effective — Ref. 4,056 [.1597]
 - Minimum Actual — Ref. 4,018 [.1582]
- Dimension Between Two Pins — Ref. 34,272 - 34,450 [1.3493 - 1.3563]

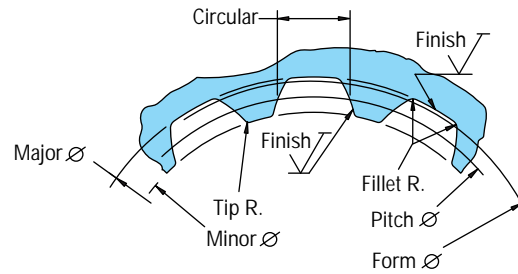

- 1 Internal spline in mating part to be as follows:
Material to be ASTM A304, 8620H.
Carborize to a hardness of 58-64 HRC with case depth (to 50HRC) of 0,076 - 1,02 [.030 - .040] (dimensions apply after heat treat).

Dimensions — Shafts

10,000 Series

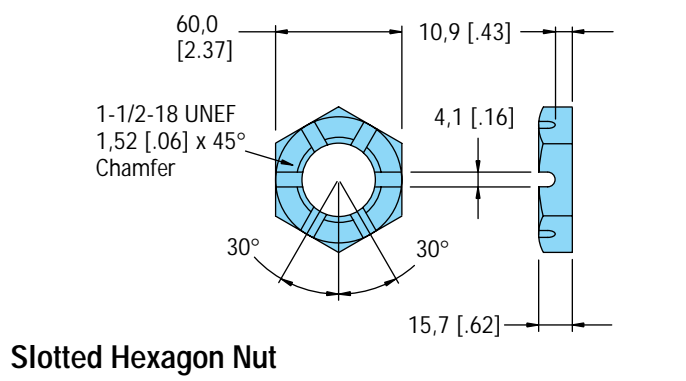
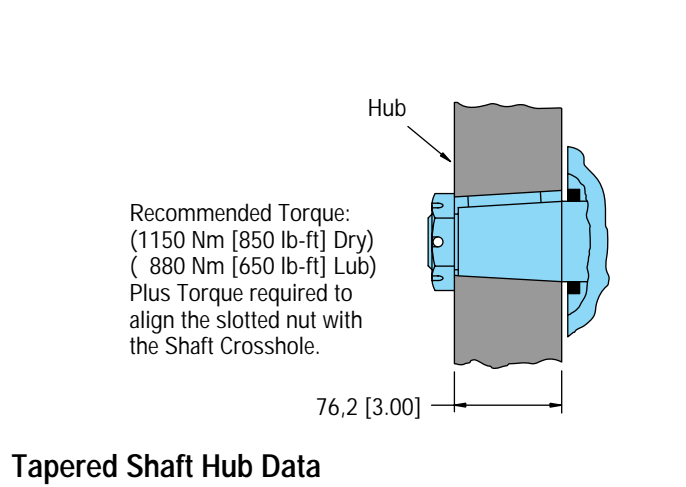
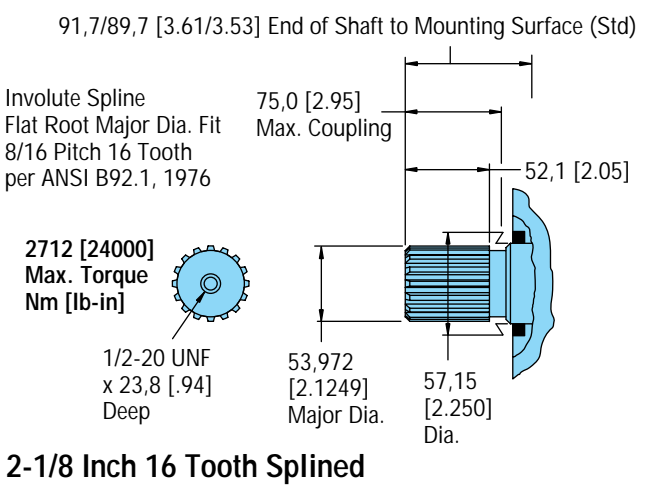
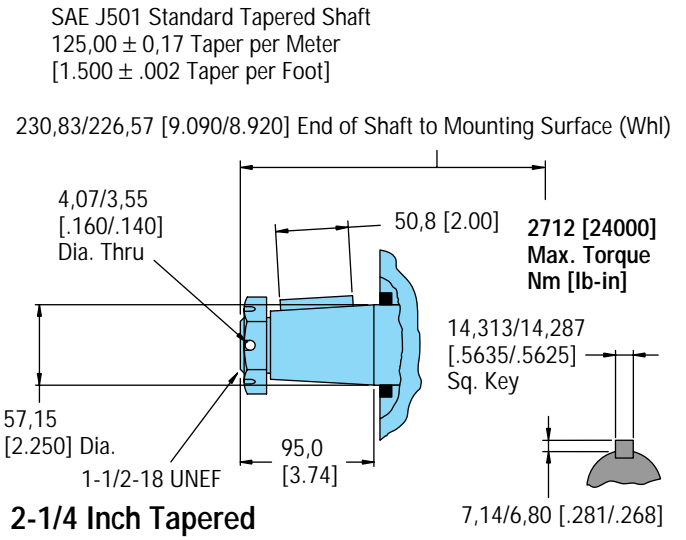
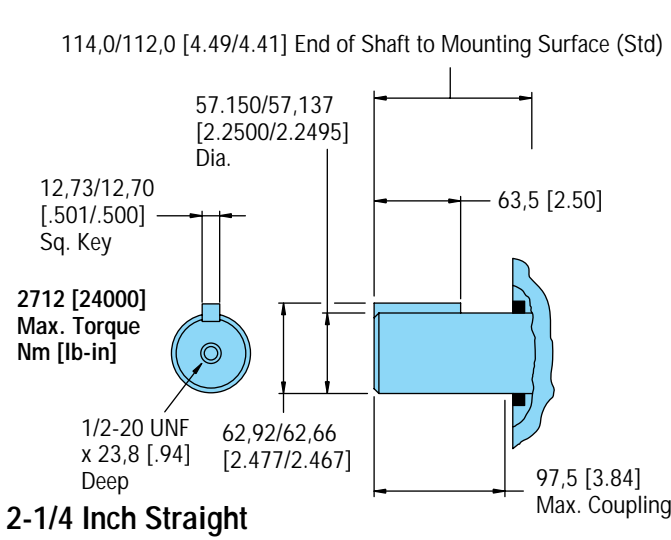

Shaft Side Load Capacity 10,000 Series

This curve indicates the radial load capacity on the motor shaft(s) at various locations.

The curve is based on B 10 Bearing life (2000 hours or 12,000,000 shaft revolutions at 100 RPM) at rated output torque. To determine radial load at speeds other than 100 RPM, multiply the load values given on the bearing curve by the factors in the chart below.

RPM	Multiplication Factor
50	1.23
100	1.00
200	.81
300	.72
400	.66
500	.62
600	.58
700	.56
800	.54

For 3,000,000 Shaft revolutions or 500 hours — Increase these shaft loads 52%.

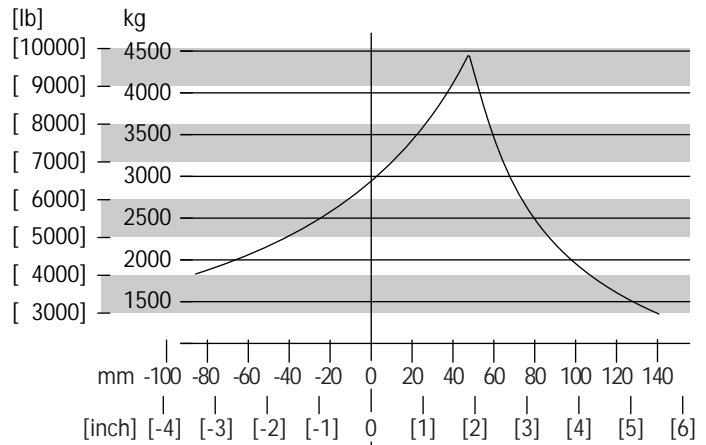

Standard Motor

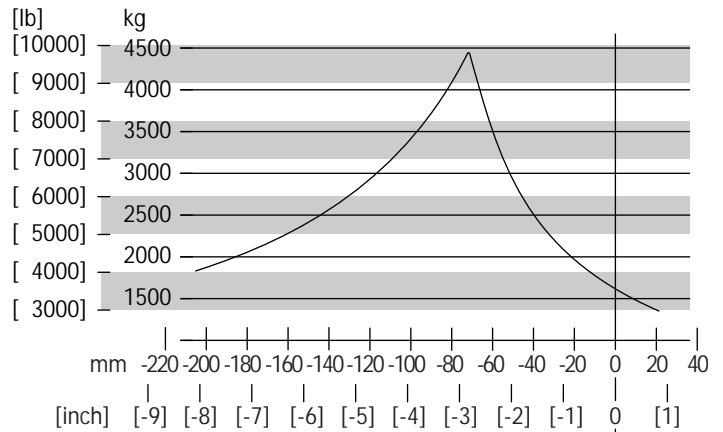
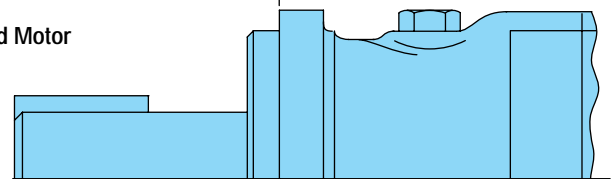

Wheel Motor

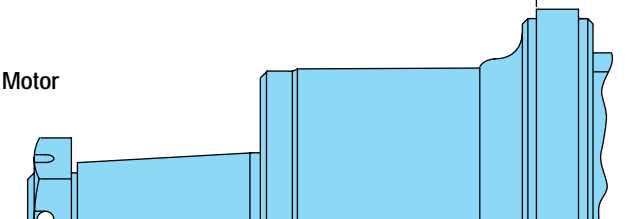

Dimensions —Ports 10,000 Series

1-1/4 Inch Split Flange Ports (2)

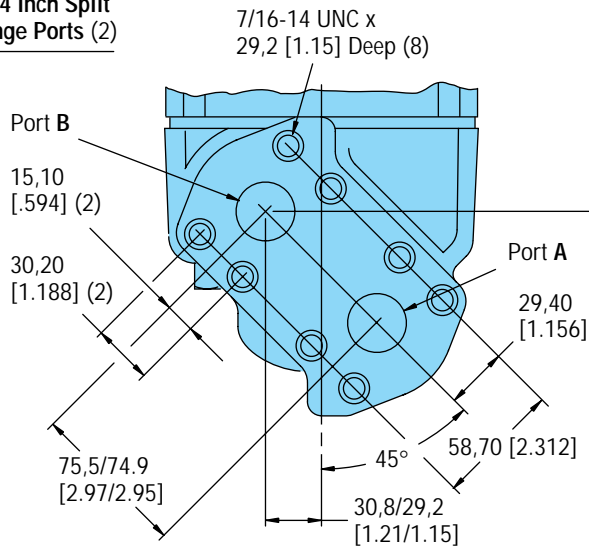

See Pages 67-69

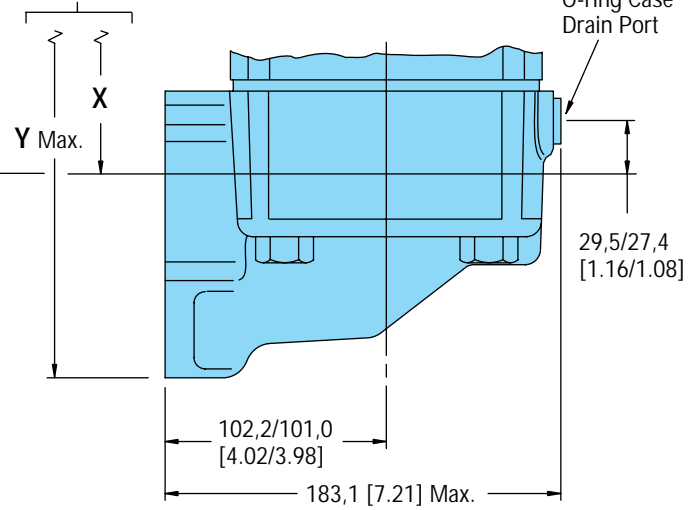

1-5/16 -12 O-ring Ports (2)

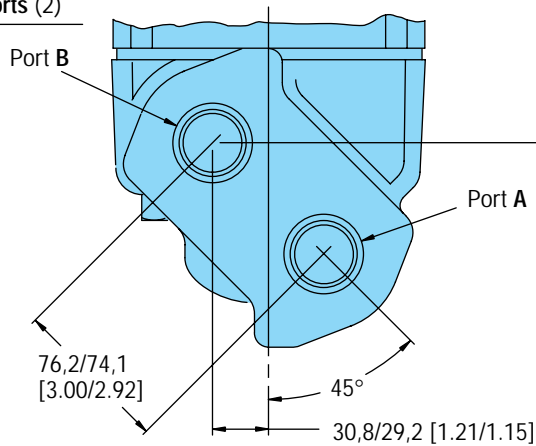

See Pages 67-69

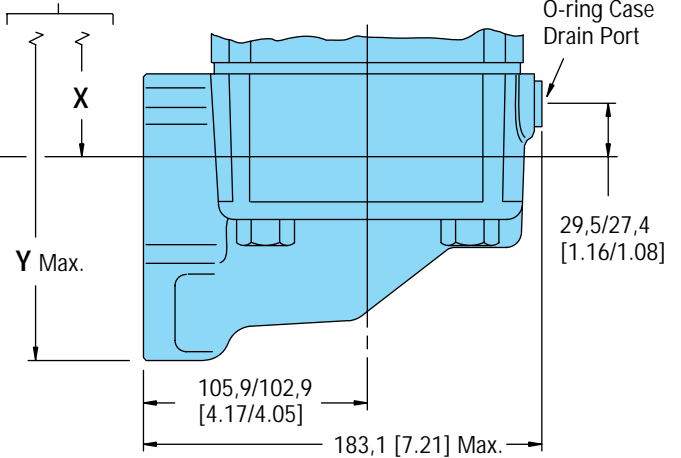

10,000 Series Motor End View—Common Dim.

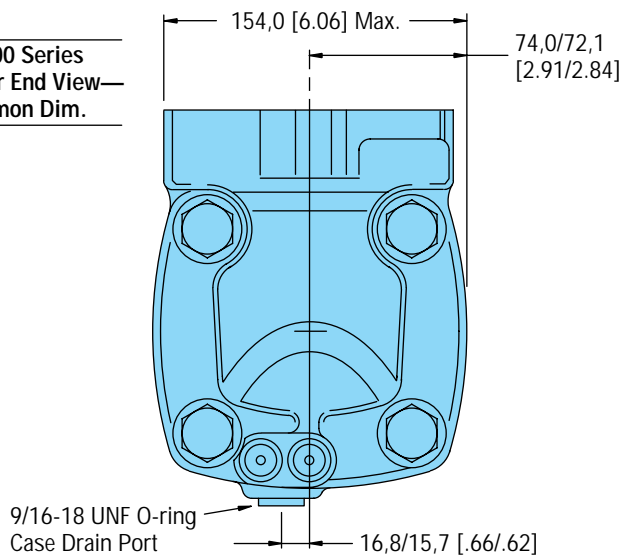

Standard Rotation 10,000 Series

Viewed from Shaft End
 Port A Pressurized — CW
 Port B Pressurized — CCW

Product Numbers 10,000 Series

Product Numbers—10,000 Series Motors

Use digit prefix —**119-**, **120-**, or **121-** plus four digit number from charts for complete product number—Example **121-1014**.
Orders will not be accepted without three digit prefix.

Mounting	Shaft	Ports	Displacement cm ³ /r [in ³ /r] and Product Number				
			345 [21.0]	480 [29.3]	665 [40.6]	940 [57.4]	
Standard	2-1/4 inch Straight	1-5/16 O-ring	119-1028	-1029	-1030	-1031	
		1-1/4 Split Flange	119-1040	-1041	-1042	-1043	
	2-1/8 Inch 16 T Splined	1-5/16 O-ring	119-1032	-1033	-1034	-1035	
		1-1/4 Split Flange	119-1044	-1045	-1046	-1047	
	2-1/4 Inch Tapered	1-5/16 O-ring	119-1036	-1037	-1038	-1039	
		1-1/4 Split Flange	119-1048	-1049	-1050	-1051	
	Wheel Motor	2-1/4 inch Straight	1-5/16 O-ring	120-1005	-1006	-1007	-1008
			1-1/4 Split Flange	120-1017	-1018	-1019	-1020
2-1/8 Inch 16 T Splined		1-5/16 O-ring	120-1009	-1010	-1011	-1012	
		1-1/4 Split Flange	120-1021	-1022	-1023	-1024	
2-1/4 Inch Tapered		1-5/16 O-ring	120-1013	-1014	-1015	-1016	
		1-1/4 Split Flange	120-1025	-1026	-1027	-1028	
Bearingless		1-5/16 O-ring		121-1007	-1008	-1009	-1010
				121-1011	-1012	-1013	-1014

121-1014

For 10,000 Series motors with a configuration *Not Shown* in the charts above: Contact your Eaton representative.

Model Code for 10,000 Series Motors

The following 14-digit coding system has been developed to identify all of the configuration options for the 10000 Series Motor. Use this model code to specify a motor with the desired features. All 14-digits of the code must be present when ordering. You may want to photocopy the matrix below to ensure that each number is entered in the correct box.

Model Code — 10,000 Series Disc Valve Motors

1	2	3	4	5	6	7	8	9	10	11	12	13	14
M	1	0										0	0

Position 1 Product Series

M Motor

Position 2, 3 10 000 Series

10 10 000 Series

Position 4, 5 Displacement cm³/r [in³/r]

20 345 [21.0]

29 480 [29.2]

40 665 [40.6]

57 940 [57.4]

Position 6 Mounting Flange

A 4 Bolt (Std.): Dia. 127,0 [5.00] Pilot 16,76 [.660]
Mounting Holes on 161,92 [6.375] Dia. Bolt Circle

B 4 Bolt (Whl.): Dia. 177,8 [7.00] Pilot 16,76 [.660]
Mounting Holes on 209,55 [8.250] Dia. Bolt Circle

C 4 Bolt (Brgl.): Dia. 152,4 [6.00] Pilot 20,70[.815]
Mounting Holes on 228,60 [9.000] Dia. Bolt Circle

Position 7, 8 Output Shaft

01 2-1/4 inch Dia. Straight with 12,7 [.50] Square Key x
63,5 [2.50] and 1/2 - 20 Threaded Hole

02 2-1/4 inch Dia. Tapered with 14,3 [.56] Square Key x
50,8 [2.00] and 1-1/2 - 18 UNEF-2A Threaded Shaft
End and Slotted Hex Nut

03 2-1/8 inch 16 Tooth Splined with 52,1 [2.05] Min.
Full Spline Length 1/2 - 20 UNF Threaded Hole

Position 9 Port Type

A 1-5/16—12 UN O-ring End Ports (Size -16), 9/16-18
UNF O-ring Case Drain Port (Size -6)

B 1-1/4 Inch Split Flange Ports, 9/16 - 18 UNF O-ring
Case Drain Port (Size -6)

Position 10, 11 Special Features (Hardware)

00 None

01 Free Running Geroler

03 Reverse Rotation

Position 12 Paint/Special Packaging

0 No Paint

A Painted Low Gloss Black

Position 13 Eaton Assigned Code when Applicable

0 Assigned Code

Position 14 Eaton Assigned Design Code

0 Assigned Design Code

Two Speed Motor — 10,000 Series

The Eaton 10,000 Series motors are available with an integral two speed feature that changes the displacement in a ratio of 1 to 2 and shifts the motor from a low speed high torque (LSHT) mode to a high speed low torque (HSLT) mode. The open center selector valve shifts the speed mode from low to high speed when pilot pressure of 6.9 Bar [100 Δ PSI] minimum is applied to the pilot port (6.9 Bar [100 PSI] higher than case pressure). In the high speed mode torque values are approximately one half with twice the speed of the conventional 10,000 Series single speed motors.

An external two position three way valve is required for shifting the pilot pressure port between signal pressure (HSLT) and low pressure (LSHT)

Two speed motors are available with a return line closed center shuttle for closed circuit applications.

Low speed high torque mode is the normal position of the speed selector valve. When a differential pressure is supplied to the pilot port and 6,9 Bar [100 PSI] is reached, the selector valve overcomes the return spring force and the spool shifts to the high speed mode. The oil in the opposite side of the spool is drained internally. Pressure between the pilot supply and case drain or return line (depending on open or closed circuit system) must be maintained to keep the motor in the high speed mode.

When pilot pressure is removed from the pilot port the pressure in the pilot end of the spool valve is relieved and drained back through this three way valve, the spring force returns the spool valve to LSHT position.

Pilot pressure may come from any source that will provide uninterrupted pressure during the high speed mode operation. Pilot pressure 6,9 Bar [100 Δ PSI] minimum, up to the full operating pressure of the motor.

In normal LSHT operation the Char-Lynn two speed motor will function with equal shaft output in either direction (CW or CCW), the same as the single speed Char-Lynn disc valve motors.

However, to prevent cavitation in the HSLT mode, the preferred direction of shaft rotation is counter clockwise (port B pressurized). This unique disc valve is not symmetrical in porting the fluid for the HSLT mode. Consequently, when the pressure is reversed for HSLT CW rotation, cavitation can occur. Installing a restriction (14 - 34 Bar [200 - 500 PSI]) in the hydraulic line that connects port B will prevent cavitation (see page 75).

If you are operating in a critical area and a restriction in the hydraulic line causes concern, these two speed motors can be ordered timed with CW preferred HSLT shaft rotation. Hence, with this option port B will have to be pressurized for CW preferred HSLT shaft rotation. The restriction recommended for the line connecting port B remains unchanged. Finally in closed circuit applications a hydraulic line restriction is not required. Instead, the charge pump can be used to supply and maintain a minimum pressure of 14 Bar [200 PSI].

Note: Be certain in closed loop applications that the charge pump when used for back pressure on the B port, has sufficient displacement to maintain charge pressure especially in dynamic braking or overrunning load conditions.

Important! Due to potential problems in maintaining charge pump pressure at port B for uninterrupted back pressure during dynamic braking, Eaton does not recommend the two speed motor where overrunning conditions may exist.

Performance Data Two Speed Motor — 10,000 Series

In the high speed mode torque values are approximately one half with twice the speed of the conventional 10,000 Series single speed motors. In the low speed mode torque and speed values are the same as the conventional

Two Speed Motor — 10,000 Series

Pump Pressure and Return, and
Shaft Rotation Directional Control Valve

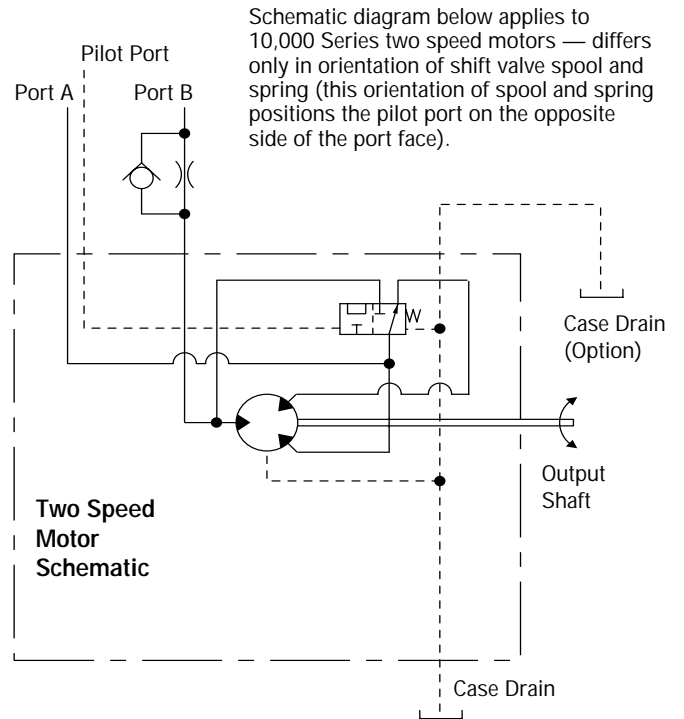
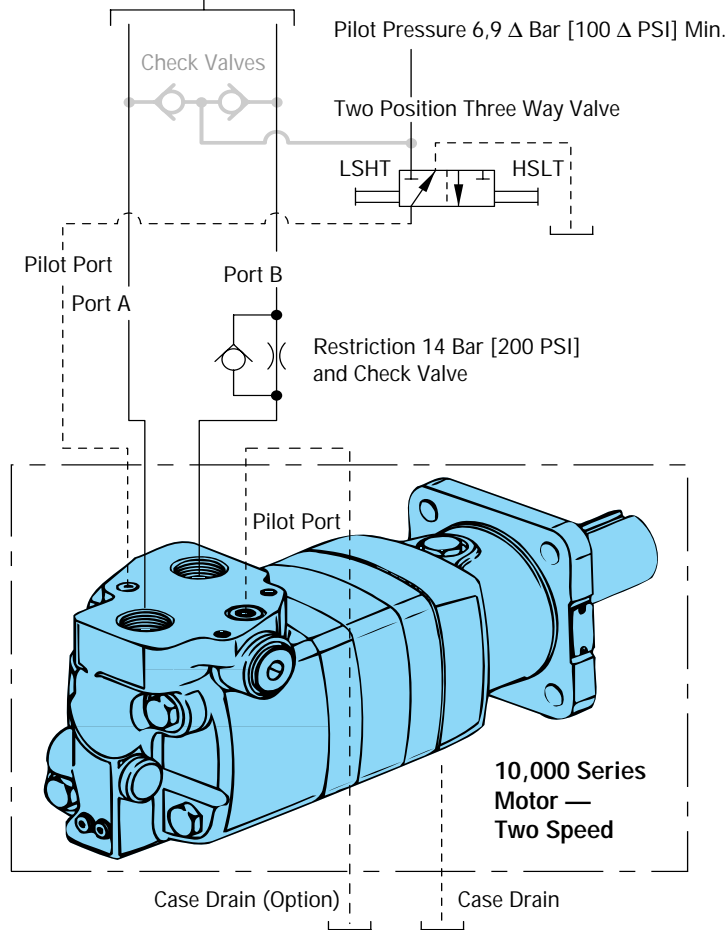

Schematic diagram below applies to 10,000 Series two speed motors — differs only in orientation of shift valve spool and spring (this orientation of spool and spring positions the pilot port on the opposite side of the port face).

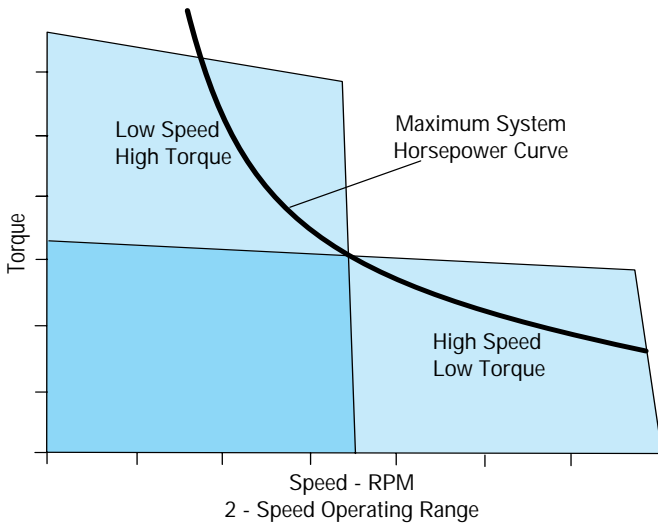

Specifications — Two Speed 10,000 Series

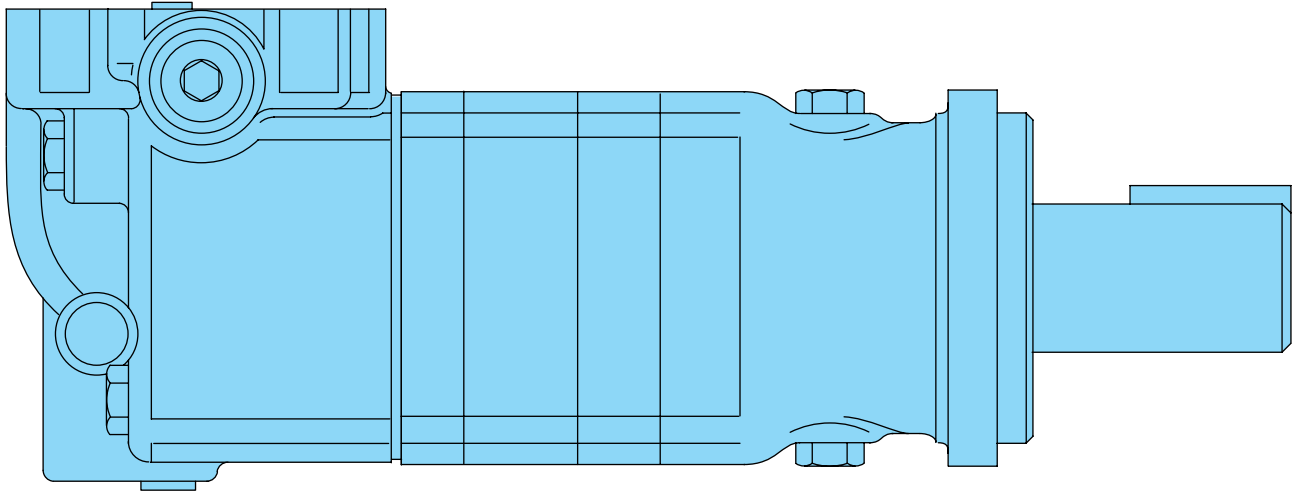

Specification Data—10,000 Series Two Speed

Displ. cm ³ /r. [in ³ /r]	High Speed Mode		169 [10.3]	239 [14.6]	332.7 [20.3]	470 [28.7]
	Low Speed Mode		345 [21.0]	480 [29.3]	665 [40.6]	940 [57.4]
Max. Speed (RPM) @ Continuous Flow	High Speed Mode		750	630	500	400
	Low Speed Mode		375	315	250	200
Flow LPM [GPM]	High Speed Mode		130 [35]	170 [45]	170 [45]	170 [45]
	Low Speed Mode		130 [35]	170 [45]	170 [45]	170 [45]
Torque Nm [lb-in]	High Speed Mode	Continuous	440 [3900]	630 [5600]	905 [8000]	1175 [10400]
		Intermittent	585 [5200]	845 [7500]	1130 [10000]	1470 [13000]
Torque Nm [lb-in]	Low Speed Mode	Continuous	1015 [9000]	1470 [13000]	2090 [18500]	2710 [24000]
		Intermittent	1355 [12000]	1965 [17400]	2600 [23000]	3445 [30500]
Pressure Δ Bar [Δ PSI]	Continuous		205 [3000]	205 [3000]	205 [3000]	190 [2750]
	Intermittent		275 [4000]	275 [4000]	260 [3750]	240 [3500]

Maximum Case Pressure - without Case Drain * — 20 Bar [300 PSI]

High Speed Mode (Reduced Motor Displacement)

Low Speed Mode (Full Motor Displacement)

Maximum torque and flow must not occur simultaneously. For permissible continuous and intermittent operating combinations of pressure and flow refer to performance data on pages 65-66 (LSHT only).

* For back pressure over 20 Bar [300 PSI] use an external case drain. Install case drain lines so that the motor case remains filled at all times.

Maximum inlet pressure — 275 Bar [4000 PSI]. Do not exceed Δ pressure rating (see chart above).

* **Maximum return pressure** — 275 Bar [4000 PSI]. Do not exceed Δ pressure rating (see chart above).

Δ Bar [Δ PSI] — True pressure difference between inlet port and outlet port.

Continuous Rating — Motor may be run continuously at these ratings.

Intermittent Operation — 10% of every minute.

Recommended Fluids — Premium quality, anti-wear type hydraulic oil with a viscosity of not less than 70 SUS at operating temperature (see page 81).

Recommended Maximum System Operating Temp. — Is 82° C [180° F]

Recommended Filtration — per ISO Cleanliness Code, level 18/13

To assure best motor life, run motor for approximately one hour at 30% of rated pressure before application to full load. Be sure motor is filled with fluid prior to any load applications.

Dimensions — Two Speed 10,000 Series Standard, Wheel, and Bearingless

Two Speed Standard Motor

Displ. cm ³ /r [in ³ /r]	345 [21.0]	480 [29.2]	665 [40.6]	940 [57.4]
X Dim. mm [inch]	270,8 [10.66]	283,5 [11.16]	283,5 [11.16]	301,8 [11.88]
Y Dim. mm [inch]	392,7 [15.46]	405,4 [15.96]	405,4 [15.96]	423,9 [16.69]

Two Speed Wheel Motor

X Dim. mm [inch]	155,2 [6.11]	167,6 [6.60]	167,6 [6.60]	186,2 [7.33]
Y Dim. mm [inch]	278,1 [10.95]	290,8 [11.45]	290,8 [11.45]	309,1 [12.17]

Two Speed Bearingless Motor

X Dim. mm [inch]	146,0 [5.75]	159,0 [6.26]	159,0 [6.26]	177,5 [6.99]
Y Dim. mm [inch]	265,5 [10.57]	281,2 [11.07]	281,2 [11.07]	299,5 [11.79]

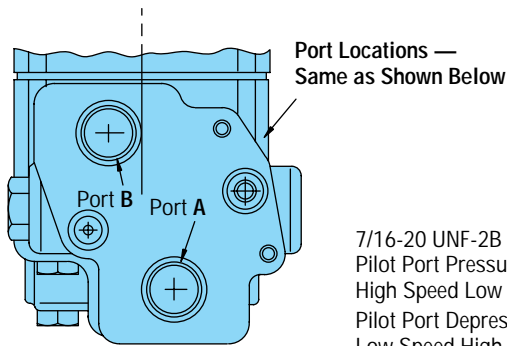
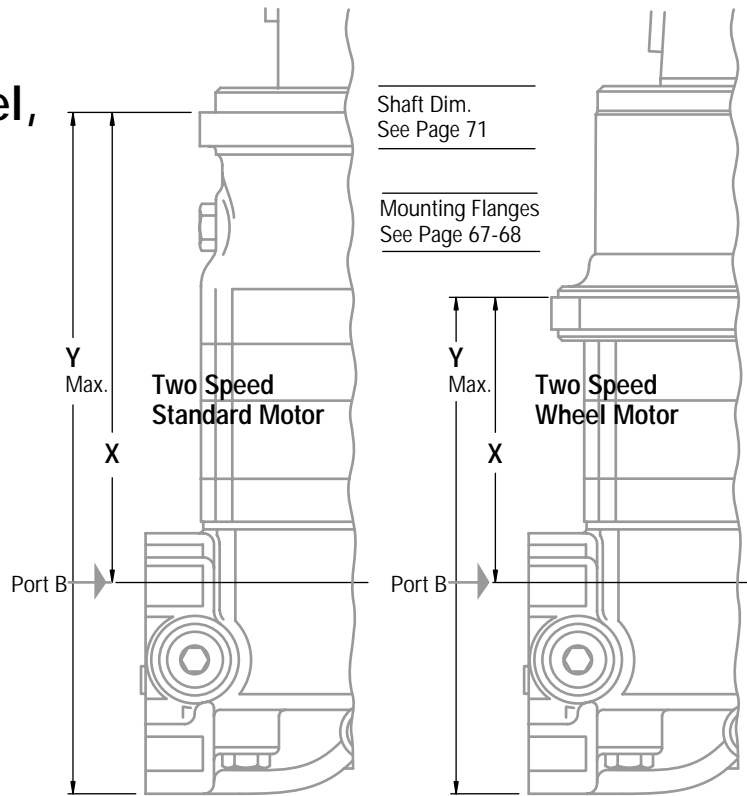

1-5/16-12 O-ring Ports (2)

1/2-20 UNF-2B O-ring Case Drain Port Size 5

7/16-20 UNF-2B O-ring Port — Pilot Control
Pilot Port Pressurized 6,9 Δ Bar [100 Δ PSI]
High Speed Low Torque (HSLT)
Pilot Port Depressurized (Tank)
Low Speed High Torque (LSHT)

Groove Provided for Seal
25,38 [.999] OD x 2,41 [.095] Wide
1,19 [.047] Deep

1-1/4 Inch Split Flange Ports (2)

19,6/18,5 [.77/1.73]
39,2/37,0 [1.54/1.46]
59,2/58,1 [2.33/2.29]

3/8-24 UNF-2B x
15,8 [.62] Min. Deep (2)

14,3/13,2 [.56/1.52]
28,2/26,6 [1.11/1.05]

Standard Rotation
Viewed from Shaft or Drive End
Port A Pressurized — CW
Port B Pressurized — CCW

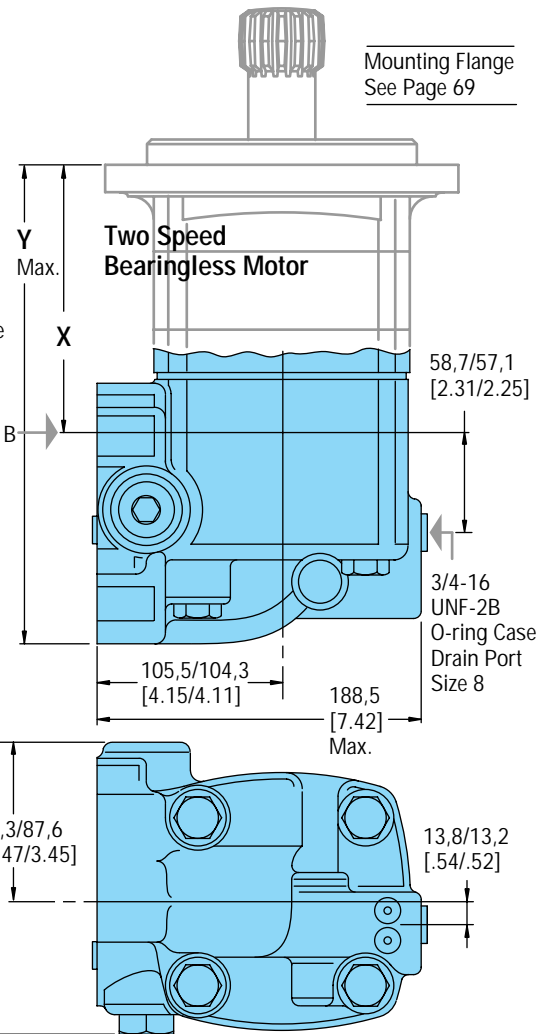

Product Numbers — Two Speed 10,000 Series

Product Numbers—10,000 Series Motors—2 Speed

Use digit prefix —119-, 120-, or 121- plus four digit number from charts for complete product number—Example 121-2002.
Orders will not be accepted without three digit prefix.

Mounting	Shaft	Ports	Displ. cm ³ /r [in ³ /r] Product Number				
			345 [21.0]	480 [29.3]	665 [40.6]	940 [57.4]	
Standard	2-1/4 inch Straight	1-5/16 O-ring	119-2013	-2014	-2015	-2016	
		1-1/4 Split Flange	119-2001	-2002	-2003	-2004	
	2-1/4 Inch Tapered	1-5/16 O-ring	119-2017	-2018	-2019	-2020	
		1-1/4 Split Flange	119-2005	-2006	-2007	-2008	
	2-1/8 Inch 16 T Splined	1-5/16 O-ring	119-2021	-2022	-2023	-2024	
		1-1/4 Split Flange	119-2009	-2010	-2011	-2012	
	Wheel Motor	2-1/4 inch Straight	1-1/4 Split Flange	120-2005	-2006	-2007	-2008
			2-1/4 Inch Tapered	1-5/16 O-ring	120-2013	-2014	-2015
1-1/4 Split Flange		120-2001		-2002	-2003	-2004	
2-1/8 Inch 16 T Splined		1-1/4 Split Flange	120-2009	-2010	-2011	-2012	
		Bearingless	1-5/16 O-ring	121-2005	-2006	-2007	-2008
1-1/4 Split Flange			121-2001	-2002	-2003	-2004	

121-2002

10,000 Series Motors with a configuration *Not Shown* in the charts above: Contact your Eaton Representative.

Fluid Recommendations

Char-Lynn Disc Valve Motors

Introduction

The ability of Eaton hydraulic components to provide the desired performance and life expectancy depends largely on the fluid used. The purpose of this section is to provide readers with the knowledge required to select the appropriate fluids for use in systems that employ Eaton hydraulic components.

One of the most important characteristics to consider when choosing a fluid to be used in a hydraulic system is viscosity. Viscosity choice is always a compromise; the fluid must be thin enough to flow easily but thick enough to seal and maintain a lubricating film between bearing and sealing surfaces. See chart below for viscosity requirements.

Viscosity and Temperature

Fluid temperature affects viscosity. In general, as the fluid warms it gets thinner and its viscosity decreases. The opposite is true when fluid cools. When choosing a fluid, it is important to consider the start-up and operating temperatures of the hydraulic system. Generally, the fluid is thick when the hydraulic system is started. With movement, the fluid warms to a point where a cooling system begins to operate. From then on, the fluid is maintained at the temperature for which the hydraulic system was designed. In actual applications this sequence varies; hydraulic systems are used in many environments from very cold to very hot. Cooling systems also vary from very elaborate to very simple, so ambient temperature may affect operating temperature. Equipment manufacturers who use Eaton hydraulic components in their products should anticipate temperature in their designs and make the appropriate fluid recommendations to their customers.

Cleanliness

Cleanliness of the fluid in a hydraulic system is extremely important. Eaton recommends that the fluid used in its hydraulic components be maintained at ISO Cleanliness Code 18/13 per SAE J1165. This code allows a maximum of 2500 particles per milliliter greater than 5 μm and a maximum of 80 particles per milliliter greater than 15 μm . Cleanliness requirements for specific products are given in the table below. OEM's and distributors who use Eaton hydraulic components in their products should provide for these requirements in their designs. A reputable filter supplier can supply filter information.

Char-Lynn Disc Valve Motors	Viscosity		ISO Cleanliness Requirements
	Minimum	Best Range	
	70 SUS 13 cSt	100-200 SUS 20-43 cSt	18/13

Additional Notes:

- Fluids too thick to flow in cold weather start-ups will cause pump cavitation and possible damage. **Motor cavitation is not a problem during cold start-ups (with one exception — two speed motors).**
- Minimum / Maximum operating temperatures are -29° C / 82° C [-20° F / 180° F].
- When choosing a hydraulic fluid, all the components in the system must be considered and the best viscosity range adjusted accordingly. For example, when a medium duty piston pump is combined with a Geroler motor the best viscosity range becomes

Fluid Maintenance

Maintaining correct fluid viscosity and cleanliness level is essential for all hydraulic systems. Since Eaton hydraulic components are used in a wide variety of applications it is impossible for Eaton to publish a fluid maintenance schedule that would cover every situation. Field testing and monitoring are the only ways to get accurate measurements of system cleanliness. OEM's and distributors who use Eaton hydraulic components should test and establish fluid maintenance schedules for their products. These maintenance schedules should be designed to meet the viscosity and cleanliness requirements laid out in this document.

Fluid Selection

Premium grade petroleum based hydraulic fluids will provide the best performance in Eaton hydraulic components. These fluids typically contain additives that are beneficial to hydraulic systems. **Eaton recommends fluids that contain anti-wear agents, rust inhibitors, anti-foaming agents, and oxidation inhibitors.** Premium grade petroleum based hydraulic fluids carry an ISO VG rating.

SAE grade crankcase oils may be used in systems that employ Eaton hydraulic components, but it should be noted that these oils may not contain all of the recommended additives. This means using crankcase oils may increase fluid maintenance requirements.

Hydraulic fluids that contain V.I. (viscosity index) improvers, sometimes called multi-viscosity oils, may be used in systems that employ Eaton hydraulic components. These V.I. improved fluids are known to "shear-down" with use. This means that their actual viscosity drops below the rated value. Fluid maintenance must be increased if V.I. improved fluids are used. Automotive automatic transmission fluids contain V.I. improvers.

Synthetic fluids may be used in Eaton hydraulic components. A reputable fluid supplier can provide information on synthetic fluids. Review applications that require the use of synthetic fluids with your Eaton representative.

100 - 150 SUS [20 - 32 cSt] and viscosity should never fall below 70 SUS [13 cSt].

- If the natural color of the fluid has become black it is possible that an overheating problem exists.
- If the fluid becomes milky a water contamination problem may exist.
- Take fluid level reading when the system is cold.
- Contact your Eaton representative if you have specific questions about the fluid requirements of Eaton hydraulic components.

Motor Application Information — Vehicle Drive Calculations

Step One — Calculate Motor Speed (RPM)

$$\text{RPM} = \frac{2.65 \times \text{KPH} \times G}{R_m} \quad \text{RPM} = \frac{168 \times \text{MPH} \times G}{R_1}$$

where KPH = vehicle speed (kilometers per hour)
 where MPH = vehicle speed (miles per hour)
 R_m = rolling radius of tires (meter)
 R₁ = rolling radius of tires (inch)
 G = gear reduction ratio (if any) between motors and wheels. If no gear box or other gear reduction devices are used G = 1.

If vehicle speed is expressed in m/second, multiply by 3.6 to convert to KPH.

If vehicle speed is expressed in ft./second, divide by 1.47 to convert to MPH.

Step Two — Determine Rolling Resistance

Rolling resistance (RR) is the force required to propel a vehicle over a particular surface. The values in Table 1 are typical of various surfaces per 1000 lb. of vehicle weight.

$$\text{RR} = \text{GVW} \times \rho \text{ (kg) (lb)}$$

where GVW = gross (loaded) vehicle weight lb/Kg
 ρ = value from Table 1

Table 1 - Rolling Resistance Coefficients for Rubber Tires on Various Surfaces

Surface	ρ
Concrete, excellent	.010
Concrete, good	.015
Concrete, poor	.020
Asphalt, good	.012
Asphalt, fair	.017
Asphalt, poor	.022
Macadam, good	.015
Macadam, fair	.022
Macadam, poor	.037
Snow, 2 inch	.025
Snow, 4 inch	.037
Dirt, smooth	.025
Dirt, sandy	.040
Mud	.037 to .150
Sand, Gravel	.060 to .150
Sand, loose	.160 to .300

Step Three — Tractive Effort to Ascend Grade

The largest grade a vehicle can ascend is called its "gradability." Grade is usually expressed as a percent rather than in degrees. A rise of one meter in ten meters or one foot rise in ten feet of travel is a 1/10 or 10 percent grade.

$$\text{GR} = \text{GVW} (\sin \theta + \rho \cos \theta)$$

Table 2

Comparison Grade (%)	Table Slope (Degrees)
1%	0°35'
2%	1° 9'
5%	2°51'
6%	3°26'
8%	4°35'
10%	5°43'
12%	6°5'
15%	8°31'
20%	11°19'
25%	14° 3'
32%	18°
60%	31°

Step Four — Determine Acceleration Force (FA)

The force (FA) required to accelerate from stop to maximum speed (KPH) or (MPH) in time (t) seconds can be obtained from the following equation:

Step Five — Determine Drawbar Pull

Drawbar Pull (DP) is total force available at the drawbar or "hitch" after the above forces have been subtracted from the total propelling force produced by the hydraulic motors. This value is established as either:

$$\text{FA} = \frac{\text{KPH} \times \text{GVW} \text{ (kg)}}{3.6 \text{ t}}$$

FA = Acceleration Force (Newton)
 t = Time (Seconds)

$$\text{FA} = \frac{\text{MPH} \times \text{GVW} \text{ (lb)}}{22 \text{ t}}$$

FA = Acceleration Force (lb)
 t = Time (Seconds)

1. A goal or objective of the designer.
2. A force required to pull a trailer (Repeat steps two through four above using trailer weight and add the three forces together to obtain DP).

Step Six — Total Tractive Effort

The tractive effort (TE) is the total force required to propel the vehicle and is the sum of the forces determined in Steps 2 through 5.

$$TE = RR + GR + FA + DP \text{ (Kg. or lb.)}$$

_____ Drawbar pull desired
 _____ Force required to accelerate
 _____ Force required to climb a grade
 _____ Force required to overcome rolling resistance

Wind resistance forces can usually be neglected. However, it may be wise to add 10% to the above total to allow for starting resistances caused by friction in bearings and other mechanical components.

Step Seven — Calculate Hydraulic Motor Torque (T)

$$T = \frac{TE \times R_m}{N \times G \times E_g} \text{ (Nm / Motors)}$$

$$T = \frac{TE \times R_l}{N \times G \times E_g} \text{ (lb-in / Motors)}$$

where N = number of driving motors
 Eg = gear box mechanical efficiency

Step Eight—Wheel Slip

If the torque required to slip the wheel (TS) is less than the torque calculated in Step 7, the performance objectives cannot be achieved.

$$TS = \frac{W \times f \times R_m}{G \times E_g} \text{ (Nm / Motor)}$$

$$TS = \frac{W \times f \times R_l}{G \times E_g} \text{ (lb-in / Motor)}$$

Where: f = coefficient of friction
 W = loaded vehicle weight over drive wheel

Coefficient of friction (f)

Steel on steel	0.15 to 0.20
Rubber tire on dirt	0.5 to 0.7
Rubber tire on asphalt	0.8 to 1.0
Rubber tire on concrete	0.8 to 1.0
Rubber tire on grass	0.4

It may be desirable to allow the wheel to slip to prevent hydraulic system overheating when excessive loads are imposed should the vehicle stall. In this case TS should be just slightly larger than T.

Step Nine — Motor Radial Load Carrying Capacity

When a motor is used to drive a vehicle with the wheel mounted directly on the motor shaft or rotating hub, the Total Radial Load (RL) acting on the motor shaft is the vector summation of two forces acting at right angles to each other.

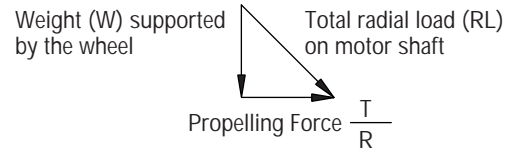

$$RL = \sqrt{W^2 + \left(\frac{T}{R}\right)^2}$$

Refer to radial load rating of each motor (see table of catalog contents page 10 for page listing of the Shaft Side Load Capacity for each motor series).

Shaft Torque

$$\frac{T}{2\pi} = \frac{q\Delta P}{62.8} \text{ Nm} = \frac{\text{PSI} \times \text{in}^3/\text{rev}}{6.28} = \text{lb-in}$$

Shaft Speed

$$\text{RPM} = \frac{\text{Flow}}{\text{Displacement}} = \frac{1000 \times \text{l/min}}{\text{cm}^3/\text{rev}} \text{ RPM} = \frac{231 \times \text{GPM}}{\text{in}^3/\text{rev}}$$

Power (into motor)

$$\text{Kw} = \frac{\text{bar} \times \text{l/min}}{600} \text{ HP} = \frac{\text{PSI} \times \text{GPM}}{1714}$$

Power (out of motor)

$$\text{Kw} = \frac{\text{Nm} \times \text{RPM}}{9549} \text{ HP} = \frac{\text{lb-in} \times \text{RPM}}{63,025}$$

where: Kw = Kilowatt
 HP = Horsepower
 LPM = Liters per Minute
 GPM = Gallons per Minute
 Nm = Newton Meters
 lb-in = Pound inch
 Bar = 10 Newtons per Square Centimeter
 PSI = Pounds per Square Inch
 q = Displacement



Information contained in this catalog is accurate as of the publication date and is subject to change without notice. Performance values are typical values. Customers are responsible for selecting products for their applications using normal engineering methods.

GREAT LAKES FLUID POWER
4170 36TH STREET SE
GRAND RAPIDS, MI 49512
Telephone: 800-968-0188
Fax: 616-949-6598
www.glhydraulics.com

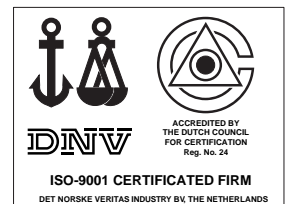

Quality System Certified
Products in this catalog are
manufactured in an
ISO-9001-certified site.