

No. 11-885  
April 1999

Char-Lynn®

Hydraulic Motors: <http://www.charlynn.com> 800-968-0188



General Purpose Motors  
H, S, and T Series

We Manufacture

Solutions

Hydraulics

S  
C  
h  
y  
d  
r  
a  
u  
n  
i  
c  
s

# Catalog of General Purpose Spool Valve Hydraulic Motors from One of the World's Leading Manufacturers of Off Highway Mobile Components — Eaton Corporation

In the late 1950's the original low speed, high torque hydraulic motor was developed from a pump gerotor element consisting of an internal gear ring and a mating gear or star. While attaching the internal gear ring to the housing as a non moving part, oil was ported to pressurize and turn the internal star in an orbit around a center point. This slow turning star coupled with a splined drive to the output shaft became the Char-Lynn® Orbit® motor.

A few years after this original Char-Lynn Orbit motor was introduced another original motor went into production. This motor had rolls incorporated into the internal ring gear. This element was identified by the name Geroler® and is a registered trade name of Eaton Corporation.

Motors with the Geroler element provide high starting and running torque. The Geroler element minimizes friction and thereby increases efficiency while providing smooth output shaft rotation even at very low speeds.

The newest Geroler motor, the "T Series", is included in this catalog. It features the latest innovations in Geroler technology. These innovations include optimized Geroler geometry with lower drive running angle for improved life and improved low speed performance. In addition, the improved housing and smaller diameter end cap results in increased envelope rigidity which improves efficiency under high pressure loads. All of these innovations come together to make the new T Series motor the highest performance motor in its class.

## Spool Valve Motors

The function of the spool valve is to distribute pressurized fluid to and from the Geroler or gerotor displacement element. The valve has hydrodynamic bearings, and has infinite life when load ratings are not exceeded.

These motors incorporate the proven orbit motor principle to provide high torque at low speeds.

Motor shaft rotation can be instantly reversed by changing direction of input/output flow while generating equal torque in either direction. The displacements available provide a wide variety of speeds and torques from any Series motor.

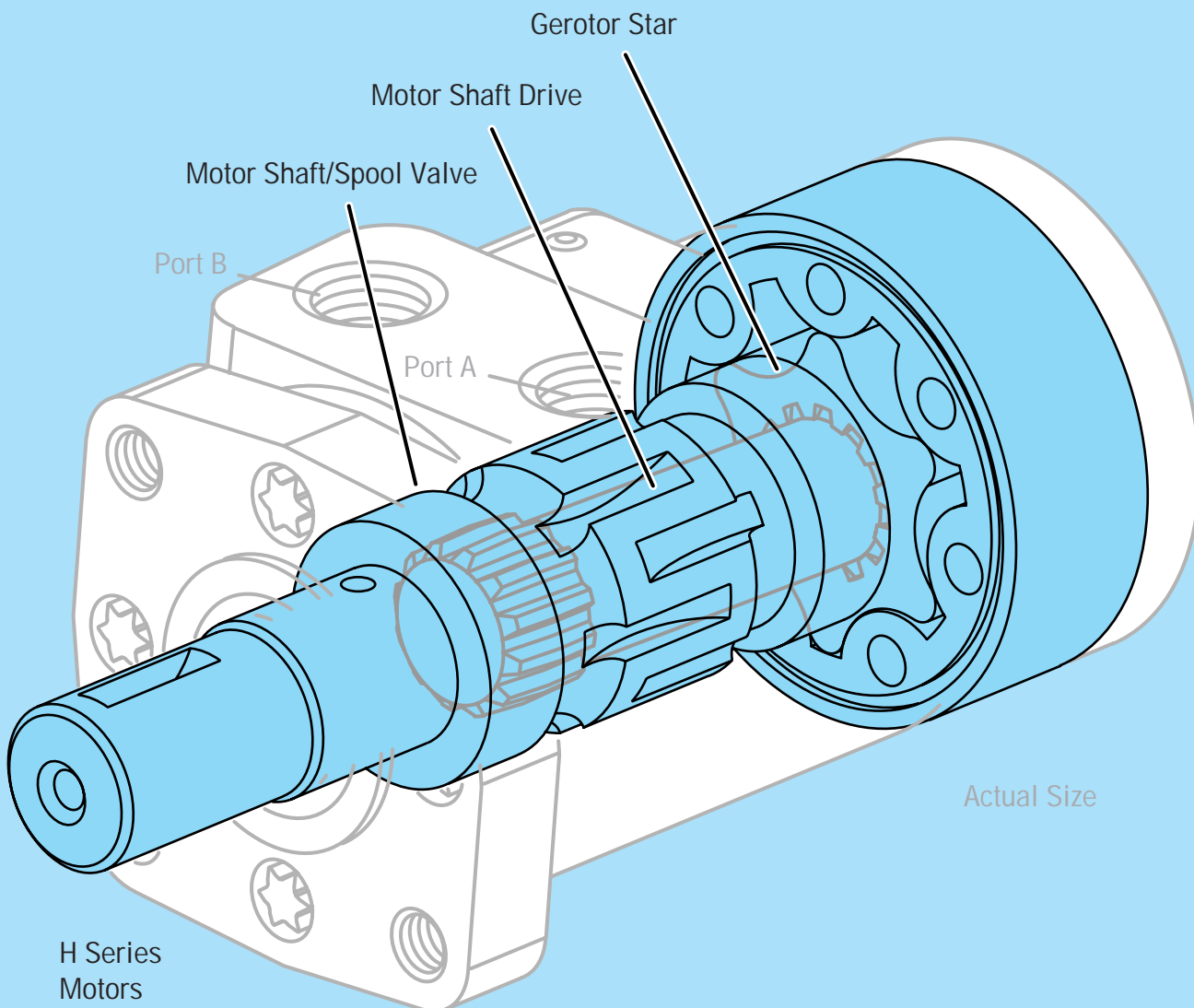

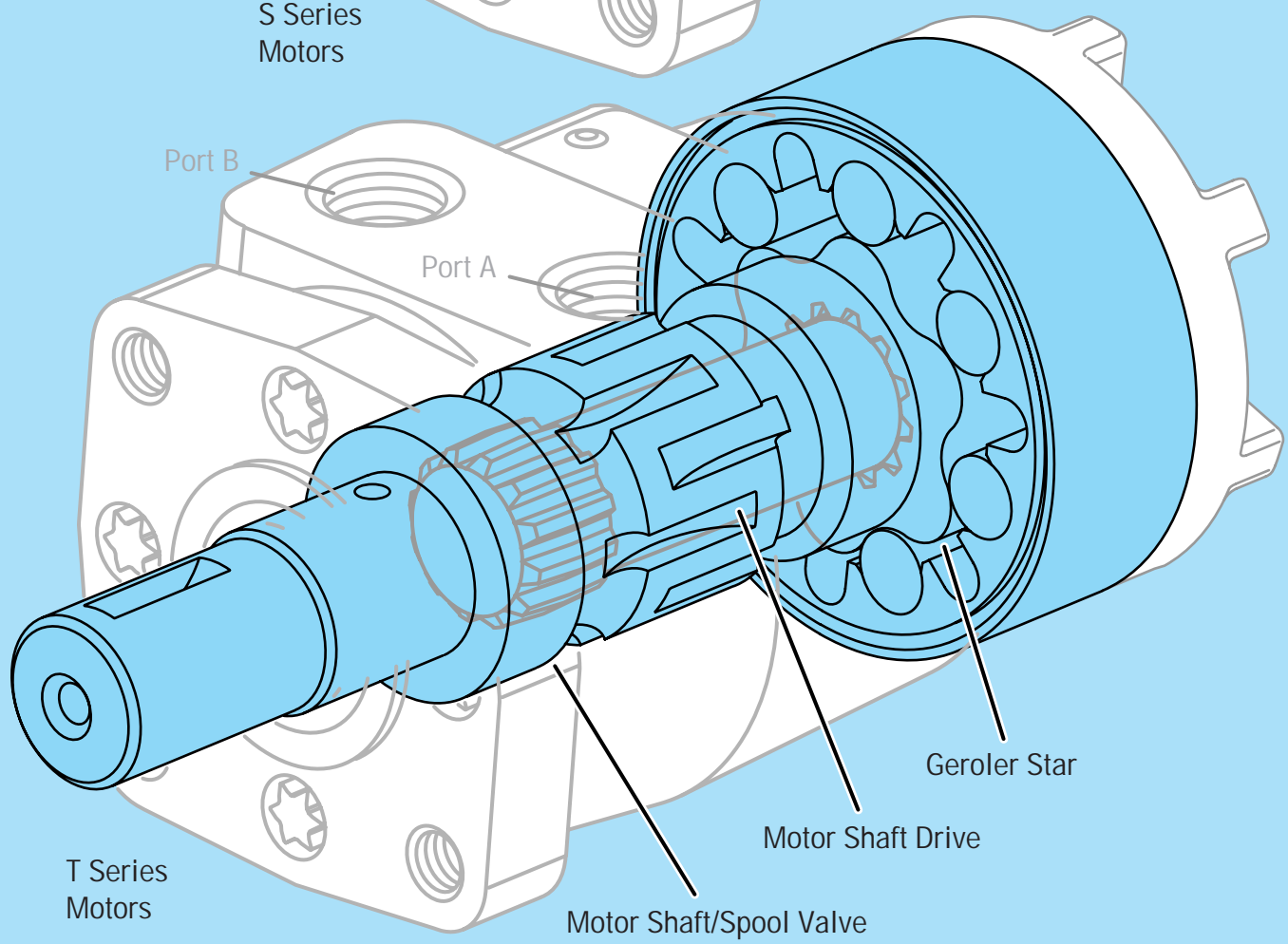
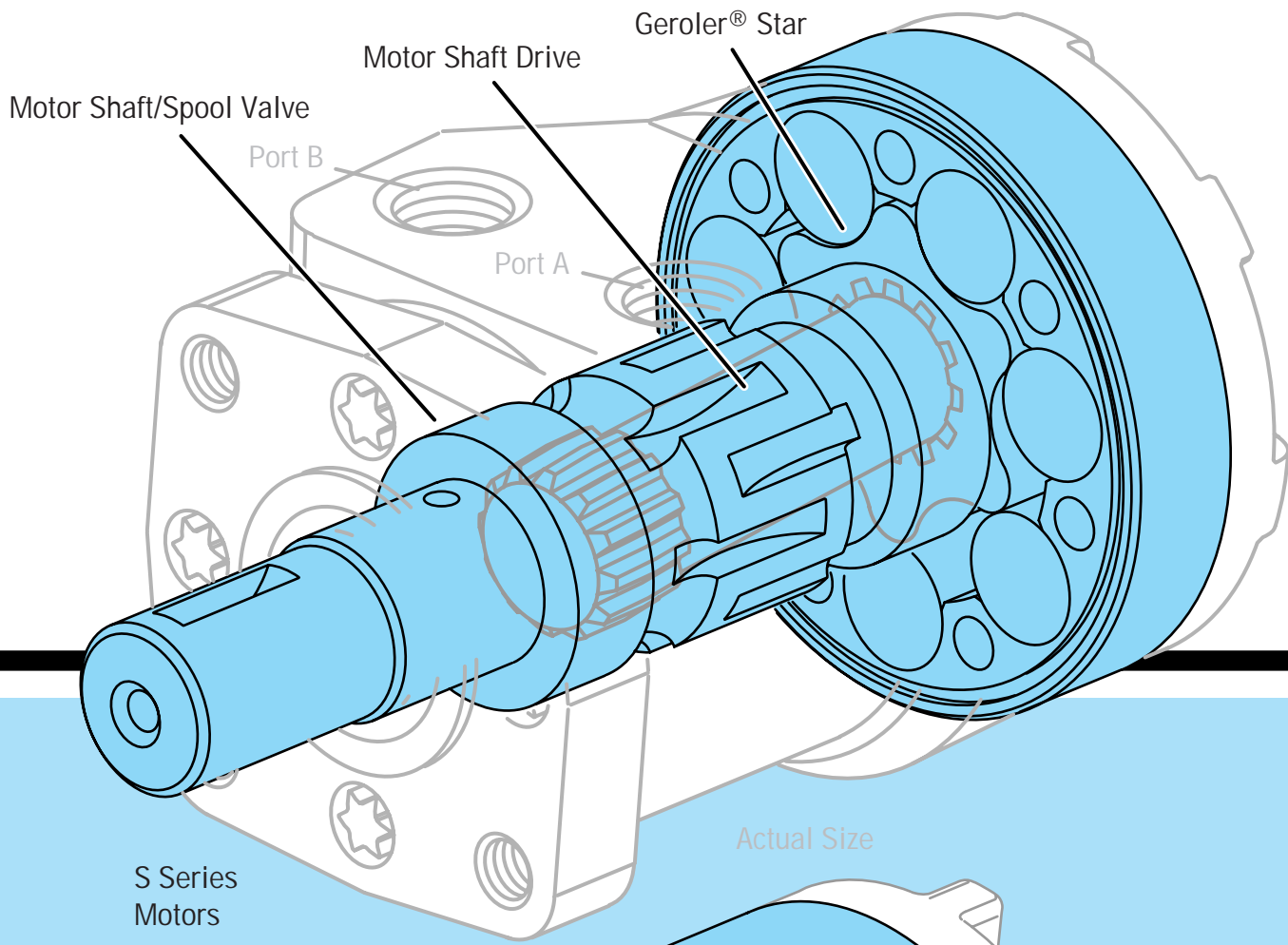

# H Series



# H

## H Series

Gerotor Element .....	13 Displacements
Flow LPM [GPM] .....	57 [15] Continuous**
	76 [20] Intermittent*
Speed .....	Up to 1100 RPM
Pressure Bar [PSI] ...	125 [1800] Cont.
	165 [2400] Inter.
Torque Nm [lb-in] ....	400 [3600] Cont.
	520 [4600] Inter.

Char-Lynn H Series motors are economical, efficient, small, compact, and powerful, designed for medium duty applications. These motors have the industry proven spool valve design combined with state-of-art gerotors. In addition, a wide variety of mounting flanges, shafts, ports, and a low speed valving option provides design flexibility. Direction of shaft rotation and shaft speed can be controlled easily and smoothly throughout the speed range of the motor, and equipment can be driven direct eliminating costly mechanical components.

\*\* Continuous— (Cont.) Continuous rating, motor may be run continuously at these ratings.

\* Intermittent— (Inter.) Intermittent operation, 10% of every minute.

H Series Displacement Size = cubic centimeter per shaft revolution (  $\text{cm}^3/\text{r}$  )  
= cubic inch per shaft revolution (  $\text{in}^3/\text{r}$  )

- 37 [ 2.2]
- 46 [ 2.8]
- 59 [ 3.6]
- 74 [ 4.5]
- 96 [ 5.9]
- 120 [ 7.3]
- 146 [ 8.9]
- 159 [ 9.7]
- 185 [11.3]
- 231 [14.1]
- 293 [17.9]
- 370 [22.6]
- 739 [45.1]

### Mounting Flange

- 2 Bolt (Std.) 82,6 [3.25] Pilot Dia. and 13,59 [.535] Dia. Mounting Holes 106,2 [4.18] Dia. B.C.
- 4 Bolt (Std.) 44,4 [1.75] Pilot Dia. and 3/8-16 Mounting Holes 82,6 [3.25] Dia. B.C.
- 4 Bolt (Std.) 44,4 [1.75] Pilot Dia. and M10 x 1,5 Mounting Holes 82,6 [3.25] Dia. B.C.
- 2 Bolt (Std.) 101,6 [4.00] Pilot Dia. and 14,35 [.565] Dia. Mounting Holes 146,0 [5.75] Dia. B.C. (SAE B)
- 4 Bolt Magneto 82,6 [3.25] Pilot Dia. and 13,59 [.535] Dia. Mounting Holes 106,2 [4.18] Dia. B.C.

### Output Shaft

- 1 inch Dia. Straight with Woodruff Key and 1/4-20 Threaded Hole
- 1 inch Dia. SAE 6B Splined with 1/4-20 Threaded Hole
- 1 inch Dia. Straight with 7,9 [ .31] Dia. Crosshole 11,2 [ .44] from End
- 1 inch Dia. Straight with 10,2 [ .40] Dia. Crosshole 15,7 [ .62] from End and 1/4-20 Threaded Hole
- 7/8 inch Dia. SAE B 13 T Splined
- 7/8 inch Dia. SAE B Straight with Square Key
- 1 inch Dia. Tapered with Woodruff Key and Nut
- 25mm Dia. Straight with 8mm Key and 8mm x 1,2 Threaded Hole
- 1 inch Dia. Straight with Woodruff Key and 1/4-20 Threaded Hole (Plated for Corrosion Protection)
- 25mm Dia. Straight with 8mm Key and 8mm x 1,2 Threaded Hole (Plated for Corrosion Protection)
- 1 inch Dia. Straight with 10,2 [ .40] Dia. Crosshole 15,7 [ .62] from End and 1/4-20 Threaded Hole (Plated...)
- 1 inch Dia. Tapered with Woodruff Key and Nut (Plated for Corrosion Protection)

### Port Type

- 7/8-14 O-ring
- 1/2-14 NPTF
- Manifold (5/16-18 Mounting Threads)
- Manifold (M8 x 1,25 Mounting Threads)
- G 1/2 (BSP) O-ring
- 3/4-16 End Ported
- G 1/2 (BSP) End Ported

### Case Drain

- No Case Drain
- 7/16-20 O-ring Port (End Cap)
- G 1/4 (BSP End Cap)

### Special Features Available

- Free Running Gerotor
- Low Speed Valve
- Viton® Shaft Seal
- Reverse Rotation
- Flange Rotated 90°
- Corrosion Protected
- Speed Sensor
- High Pressure Shaft Seal

Viton® is a Registered Trade Name of Dupont Corp.

# S Series

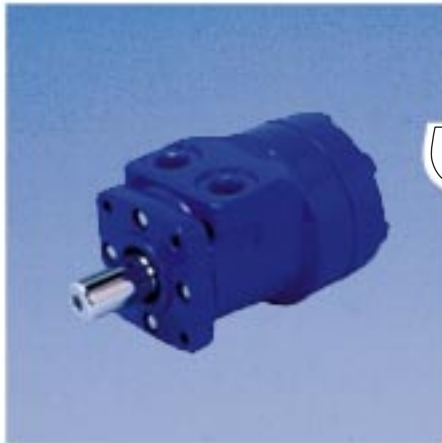

## S Series

Geroler® Element	....	10 Displacements
Flow LPM [GPM]	....	55 [15] Continuous**
		75 [20] Intermittent*
Speed	.....	Up to 1150 RPM
Pressure Bar [PSI]	...	135 [2000] Cont.
		170 [2500] Inter.
Torque Nm [lb-in]	....	450 [4000] Cont.
		515 [4550] Inter.

Char-Lynn S Series motor with Geroler offers the same advantage of low speed, high torque and compact size as the H Series with gerotor. In the Geroler element precision machined rollers form the displacement chambers. The rollers provide support with rolling contact as the star rotates, minimizing friction, providing high efficiency, especially at start-up and at low speeds.

- S Series Displacement Size = cubic centimeter per shaft revolution (cm<sup>3</sup>/r)  
= cubic inch per shaft revolution ([ in<sup>3</sup>/r ])
- 59 [ 3.6]
  - 74 [ 4.5]
  - 97 [ 5.9]
  - 120 [ 7.3]
  - 146 [ 8.9]
  - 159 [ 9.7]
  - 185 [11.3]
  - 231 [14.1]
  - 293 [17.9]
  - 370 [22.6]
- Mounting Flange
- 2 Bolt (Std.) 82,6 [3.25] Pilot Dia. and 13,59 [.535] Dia. Mounting Holes 106,2 [4.18] Dia. B.C.
  - 4 Bolt (Std.) 44,4 [1.75] Pilot Dia. and 3/8-16 Mounting Holes 82,6 [3.25] Dia. B.C.
  - 4 Bolt (Std.) 44,4 [1.75] Pilot Dia. and M10 x 1,5 Mounting Holes 82,6 [3.25] Dia. B.C.
  - 2 Bolt (Std.) 101,6 [4.00] Pilot Dia. and 14,35 [.565] Dia. Mounting Holes 146,0 [5.75] Dia. B.C. (SAE B)
  - 4 Bolt Magneto 82,6 [3.25] Pilot Dia. and 13,59 [.535] Dia. Mounting Holes 106,2 [4.18] Dia. B.C.
- Output Shaft
- 1 inch Dia. Straight with Woodruff Key and 1/4-20 Threaded Hole
  - 1 inch Dia. SAE 6B Splined with 1/4-20 Threaded Hole
  - 1 inch Dia. Straight with 7,9 [.31] Dia. Crosshole 11,2 [.44] from End
  - 1 inch Dia. Straight with 10,2 [.40] Dia. Crosshole 15,7 [.62] from End and 1/4-20 Threaded Hole
  - 7/8 inch Dia. SAE B 13 T Splined
  - 7/8 inch Dia. SAE B Straight with Square Key
  - 1 inch Dia. Tapered with Woodruff Key and Nut
  - 25mm Dia. Straight with 8mm Key and 8mm x 1,2 Threaded Hole
  - 1 inch Dia. Straight with Woodruff Key and 1/4-20 Threaded Hole (Plated for Corrosion Protection)
- Port Type
- 7/8-14 O-ring
  - 1/2-14 NPTF
  - Manifold (5/16-18 Mounting Threads)
  - Manifold (M8 x 1,25 Mounting Threads)
  - G 1/2 (BSP) O-ring
- Case Drain
- No Case Drain
  - 7/16-20 O-ring Port (End Cap)
  - G 1/4 (BSP End Cap)
- Special Features Available
- Low Speed Valve
  - Viton® Shaft Seal
  - Reverse Rotation
  - Flange Rotated 90°
  - Corrosion Protected
  - High Pressure Shaft Seal

\*\* Continuous— (Cont.) Continuous rating, motor may be run continuously at these ratings.

\* Intermittent— (Inter.) Intermittent operation, 10% of every minute.

# T Series

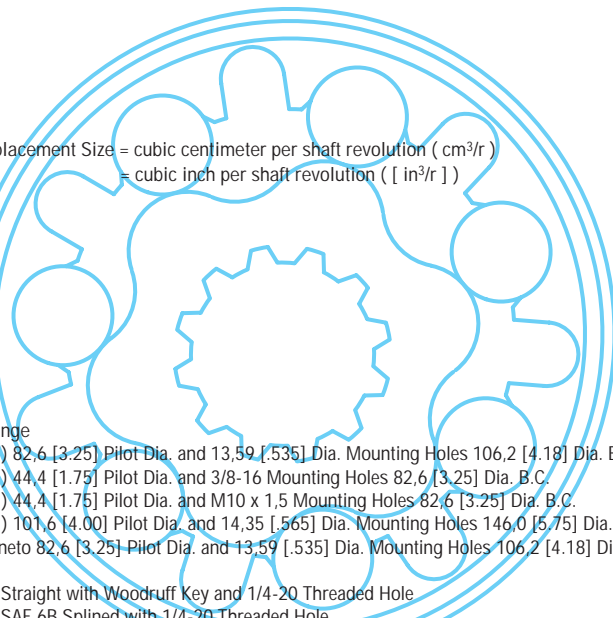
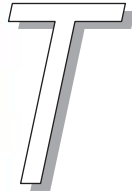

## T Series

Geroler® Element	....	11 Displacements
Flow LPM [GPM]	.....	55 [15] Continuous**
		75 [20] Intermittent*
Speed	.....	Up to 1055 RPM
Pressure Bar [PSI]	...	155 [2250] Cont.
		190 [2750] Inter.
Torque Nm [lb-in]	....	440 [3905] Cont.
		510 [4515] Inter.

Char-Lynn T Series motors with the Geroler displacement element, offer the same advantage of low friction, and long life as the S Series in a compact size like the H Series. The T Series features the simplicity of Eaton's proven spool valve and a compact Geroler element that provides better drive life and smoother performance.

T Series Displacement Size = cubic centimeter per shaft revolution (  $\text{cm}^3/\text{r}$  )  
 = cubic inch per shaft revolution (  $[\text{in}^3/\text{r}]$  )

- 36 [ 2.2]
- 49 [ 3.0]
- 66 [ 4.0]
- 80 [ 4.9]
- 102 [ 6.2]
- 131 [ 8.0]
- 157 [ 9.6]
- 195 [11.9]
- 244 [14.9]
- 306 [18.7]
- 370 [22.6]

### Mounting Flange

- 2 Bolt (Std.) 82,6 [3.25] Pilot Dia. and 13,59 [.535] Dia. Mounting Holes 106,2 [4.18] Dia. B.C.
- 4 Bolt (Std.) 44,4 [1.75] Pilot Dia. and 3/8-16 Mounting Holes 82,6 [3.25] Dia. B.C.
- 4 Bolt (Std.) 44,4 [1.75] Pilot Dia. and M10 x 1,5 Mounting Holes 82,6 [3.25] Dia. B.C.
- 2 Bolt (Std.) 101,6 [4.00] Pilot Dia. and 14,35 [.565] Dia. Mounting Holes 146,0 [5.75] Dia. B.C. (SAE B)
- 4 Bolt Magneto 82,6 [3.25] Pilot Dia. and 13,59 [.535] Dia. Mounting Holes 106,2 [4.18] Dia. B.C.

### Output Shaft

- 1 inch Dia. Straight with Woodruff Key and 1/4-20 Threaded Hole
- 1 inch Dia. SAE 6B Splined with 1/4-20 Threaded Hole
- 1 inch Dia. Straight with 7,9 [.31] Dia. Crosshole 11,2 [.44] from End
- 1 inch Dia. Straight with 10,2 [.40] Dia. Crosshole 15,7 [.62] from End and 1/4-20 Threaded Hole
- 7/8 inch Dia. SAE B 13 T Splined
- 7/8 inch Dia. SAE B Straight with Square Key
- 1 inch Dia. Tapered with Woodruff Key and Nut
- 25mm Dia. Straight with 8mm Key and 8mm x 1,2 Threaded Hole
- 1 inch Dia. Straight with Woodruff Key and 1/4-20 Threaded Hole (Plated for Corrosion Protection)

### Port Type

- 7/8-14 O-ring
- 1/2-14 NPTF
- Manifold (5/16-18 Mounting Threads)
- Manifold (M8 x 1,25 Mounting Threads)
- G 1/2 (BSP) O-ring

### Case Drain

- No Case Drain
- 7/16-20 O-ring Port (End Cap)
- G 1/4 (BSP End Cap)

### Special Features Available

- Low Speed Valve
- Viton® Shaft Seal
- Reverse Rotation
- Flange Rotated 90°
- Corrosion Protected
- Speed Sensor
- High Pressure Shaft Seal

\*\* Continuous— (Cont.) Continuous rating, motor may be run continuously at these ratings.

\* Intermittent— (Inter.) Intermittent operation, 10% of every minute.

**Shaft Seal**  
— H, S, and T Series

The time proven shaft seal design and construction allow the motors to withstand high back pressures without an external case drain. The motors can be connected together in series, or parallel to one another. The H, S, and T Series shaft seal has a patented feature which allows the seal lip to follow shaft deflection and provide better sealing under those conditions. A high pressure shaft seal is available for applications that have intermittent high case pressures above 105 bar [1500 PSI].

**Low Speed Valving**  
— Option H, S, and T Series

The low speed valving option provides smooth low speed performance while maintaining high torque. Designed to run continuously at up to 200 RPM at standard rated pressures and reduced flows, providing smooth operation at low speeds. Furthermore, they resist slippage and have more momentary load holding ability than the standard H, and S Series motors. Motors with this valving are not intended for low pressure applications (41 Bar [600 PSI] Minimum).

**Free Running Motors**  
— H, S, and T Series

H Series, S Series and T Series motors can be ordered with a special gerotor (H Series), or Geroler (S, and T Series) to permit free running of the output shaft. With this special feature, performance might be affected when extreme conditions exist. Overall efficiency may be reduced slightly.

**Corrosion Protected**  
— H, S, and T Series

H Series, S Series, and T Series motors are available with a corrosion resistant coating for use in an hostile environment. This coating protects the motor from salt, water, and various chemicals. It is especially effective in marine, food processing, car wash, fishing, and agricultural applications. Shaft plating helps eliminate seal damage caused by these caustic or acid materials in the shaft sealing area. Corrosion protected motors are available with just the output shaft plated, or protected with an entire motor exterior coating.

**Speed Sensor**  
— H, S, and T Series

The H, and T Series motors are available with a rugged digital sensor for monitoring motor shaft speed. Compatible with vehicle electrical systems, this feature is ideal for applications where speeds need to be accurately known.

**Catalog Contents**

	H Series	S Series	T Series
Specifications	page 8	page 14	page 20
Performance Data	9-11	15-17	21-25
Dimensions —Product (Mtg., Shafts, and Ports Listed Below)	12	18	26
Shaft Rotation (Standard)	12	18	26
Shaft Rotation (Reversed from Std.)	37	38	39
Product Numbers (Standard Units)	13	19	21
Specifications H, S and T Series with Low Speed Valving — Product Numbers S Series and T Series w/LSV	28	28	28
Shaft Side Load Capacity	29	29	29
Dimensions —Shafts	30-31	30-31	30-31
Dimensions —Mtg. Options/Mtg. Kit	32-33	32-33	32-33
Dimensions —Ports	33-34	33-34	33-34
Case Pressure and Case Drain	34-35	34-35	34-35
Speed Sensor	35	—	35
Fluid Recommendations	36	36	36
Model Code (Special* —Orders)	37	38	39

\* Contact your Eaton Representative

# Specifications H Series

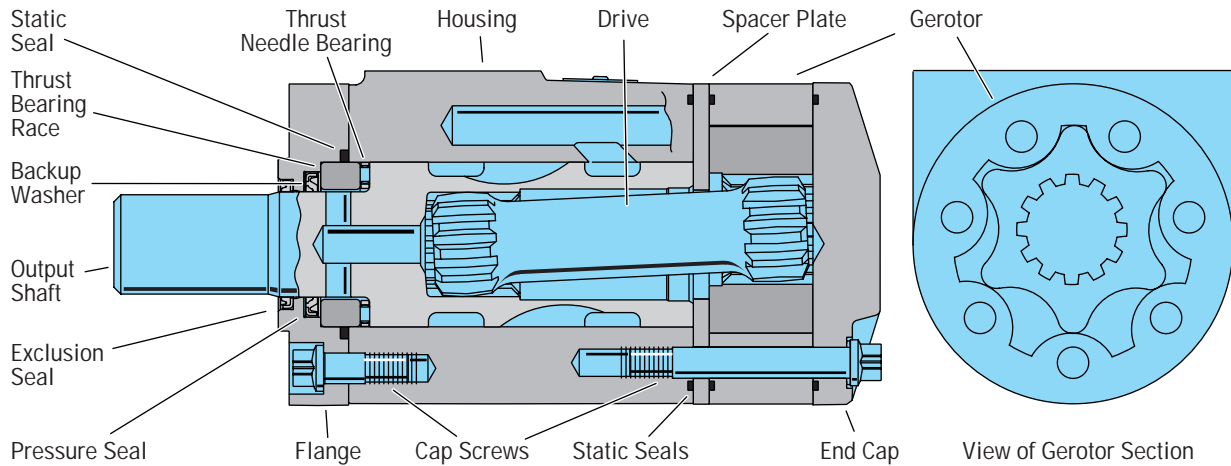

## Specification Data—H Series

Displ. cm <sup>3</sup> /r [in <sup>3</sup> /r]		36 [ 2.2]	46 [ 2.8]	59 [ 3.6]	74 [ 4.5]	97 [ 5.9]	120 [ 7.3]	146 [ 8.9]	159 [ 9.7]	185 [11.3]	231 [14.1]	293 [17.9]	370 [22.6]	739 [45.1]
Max. Speed (RPM) @ Continuous Flow		1021	969	953	760	585	469	385	353	304	243	192	152	74
Flow LPM [GPM]	Continuous	38 [10]	45 [12]	57 [15]	57 [15]	57 [15]	57 [15]	57 [15]	57 [15]	57 [15]	57 [15]	57 [15]	57 [15]	57 [15]
	Intermittent	38 [10]	53 [14]	64 [17]	68 [18]	68 [18]	76 [20]	76 [20]	76 [20]	76 [20]	76 [20]	76 [20]	76 [20]	76 [20]
Torque Nm [lb-in]	Continuous	56 [ 497]	73 [ 650]	91 [ 802]	118 [1044]	155 [1368]	192 [1699]	221 [1954]	233 [2059]	265 [2343]	302 [2669]	351 [3110]	407 [3604]	389 [3440]
	Intermittent **	75 [ 668]	99 [ 876]	122 [1076]	158 [1401]	207 [1829]	257 [2278]	300 [2653]	319 [2824]	356 [3151]	415 [3671]	466 [4121]	484 [4283]	520 [4600]
Min. Starting Torque Nm[lb-in]	@ Cont. Pressure	46 [ 410]	59 [ 520]	76 [ 670]	95 [ 840]	124 [1100]	154 [1360]	176 [1560]	186 [1650]	211 [1870]	238 [2110]	282 [2500]	330 [2920]	316 [2800]
	@ Int. Pressure	63 [ 560]	81 [ 720]	104 [ 920]	130 [1150]	171 [1510]	210 [1860]	246 [2180]	262 [2320]	293 [2590]	339 [3000]	388 [3430]	408 [3610]	434 [3840]
Pressure Δ Bar [Δ PSI]	Continuous*	124 [1800]	124 [1800]	124 [1800]	124 [1800]	124 [1800]	124 [1800]	117 [1700]	114 [1650]	110 [1600]	100 [1450]	93 [1350]	86 [1250]	41 [ 600]
	Intermittent**	165 [2400]	165 [2400]	165 [2400]	165 [2400]	165 [2400]	165 [2400]	159 [2300]	155 [2250]	148 [2150]	138 [2000]	124 [1800]	103 [1500]	55 [ 800]
Weight kg [lb]		5,1 [11.2]	5,1 [11.2]	5,2 [11.5]	5,2 [11.5]	5,4 [11.8]	5,5 [12.1]	5,6 [12.4]	5,7 [12.5]	5,8 [12.8]	6,0 [13.3]	6,3 [14.0]	6,7 [14.7]	8,4 [18,6]

Maximum Case Pressure - without Case Drain — 103 Bar [1500 PSI] — See Page 34-35

\* Maximum intermittent pressure at motor inlet port of 172 Bar [2500 PSI] without regard to Δ Bar [Δ PSI] and/or back pressure ratings or combination thereof.

\*\* A simultaneous maximum torque and maximum speed NOT recommended.

6B Splined or Tapered shafts are recommended whenever operating above 282 Nm [2500 lb-in] of torque, especially for those applications subject to frequent reversals (see page 30).

Δ Bar [Δ PSI]— True pressure difference between inlet port and outlet port.

Continuous Rating — Motor may be run continuously at these ratings.

Intermittent Operation — 10% of every minute.

Recommended Fluids — Premium quality, anti-wear type hydraulic oil. Minimum oil viscosity (at operating

temperature) should be the highest of the following: 100 SUS or  $\frac{300 \times \text{Bar}}{\text{RPM}} = \text{SUS}$   $\left[ \frac{20 \times \text{PSI}}{\text{RPM}} = \text{SUS} \right]$  (see page 36).

Recommended Maximum System Operating Temp. — Is 82° C [180° F]

Recommended Filtration — per ISO Cleanliness Code, level 18/13

To assure best motor life, run motor for approximately one hour at 30% of rated pressure before application to full load. Be sure motor is filled with fluid prior to any load applications.

# Performance Data H Series

Motors run with high efficiency in all areas designated with a number for torque and speed, however for best motor life select a motor to run with a torque and speed range shown in the light blue area.

36 cm<sup>3</sup>/r [2.2 in<sup>3</sup>/r]  
Δ Pressure Bar [PSI]

		[200]	[400]	[600]	[800]	[1000]	[1200]	[1400]	[1600]	[1800]	[2400]
		14	28	41	55	69	83	97	110	124	165
Flow LPM [GPM]	[2]	[49]	[103]	[162]	[189]	[270]	[325]	[379]	[432]	[489]	[650]
	7,6	6	12	18	21	31	37	43	49	55	73
		204	201	198	194	189	184	177	170	162	122
	[4]	[47]	[106]	[160]	[191]	[274]	[327]	[384]	[439]	[495]	[654]
	15,1	5	12	18	22	31	37	43	50	56	74
	408	407	402	399	394	387	381	373	365	323	
[6]	[44]	[102]	[158]	[188]	[272]	[328]	[383]	[440]	[496]	[661]	
22,7	5	12	18	21	31	37	43	50	56	75	
	613	612	609	604	599	591	586	576	565	523	
[8]	[40]	[97]	[153]	[184]	[270]	[326]	[383]	[440]	[497]	[668]	
30,3	5	11	17	21	31	37	43	50	56	75	
	817	817	814	807	799	793	785	776	762	721	
[10]	[36]	[90]	[148]	[180]	[265]	[322]	[380]	[438]	[495]	[664]	
37,9	4	10	17	20	30	36	43	49	56	75	
	1021	1021	1015	1008	1001	991	981	969	959	920	

[90] } Torque [lb-in]  
10 } Nm  
1021 } Speed RPM

46 cm<sup>3</sup>/r [2.8 in<sup>3</sup>/r]  
Δ Pressure Bar [PSI]

		[200]	[400]	[600]	[800]	[1000]	[1200]	[1400]	[1600]	[1800]	[2400]
		14	28	41	55	69	83	97	110	124	165
Flow LPM [GPM]	[2]	[64]	[136]	[212]	[284]	[355]	[426]	[497]	[567]	[641]	[852]
	7,6	7	15	24	32	40	48	56	64	72	96
		161	158	156	153	148	145	139	133	127	95
	[4]	[61]	[139]	[209]	[286]	[359]	[429]	[503]	[576]	[649]	[857]
	15,1	7	16	24	32	41	48	57	65	73	97
	323	320	316	314	310	304	300	293	287	253	
[6]	[58]	[134]	[207]	[282]	[356]	[430]	[502]	[577]	[650]	[867]	
22,7	7	15	23	32	40	49	57	65	73	98	
	486	481	479	475	471	464	461	453	444	410	
[8]	[52]	[128]	[200]	[276]	[354]	[428]	[502]	[577]	[651]	[876]	
30,3	6	14	23	31	40	48	57	65	74	99	
	648	643	640	635	628	623	617	610	599	566	
[10]	[47]	[118]	[194]	[269]	[347]	[423]	[498]	[575]	[649]	[871]	
37,9	5	13	22	30	39	48	56	65	73	98	
	808	803	798	793	787	779	771	761	753	722	
[12]	[36]	[109]	[188]	[260]	[340]	[417]	[492]	[567]	[643]	[864]	
45,4	4	12	21	29	38	47	56	64	73	97	
	969	964	960	952	946	938	931	922	914	877	
Max. Inter-mittent	[14]	[25]	[98]	[175]	[249]	[327]	[404]	[484]	[559]	[634]	
	53,0	3	11	20	28	37	46	55	63	72	
		1127	1123	1115	1108	1100	1093	1086	1079	1068	

59 cm<sup>3</sup>/r [3.6 in<sup>3</sup>/r]  
Δ Pressure Bar [PSI]

		[200]	[400]	[600]	[800]	[1000]	[1200]	[1400]	[1600]	[1800]	[2400]
		14	28	41	55	69	83	97	110	124	165
Flow LPM [GPM]	[2]	[79]	[169]	[260]	[305]	[437]	[526]	[616]	[704]	[796]	[1055]
	7,6	9	19	29	34	49	59	70	80	90	119
		127	125	123	121	117	114	109	103	96	65
	[4]	[76]	[168]	[257]	[307]	[441]	[529]	[620]	[710]	[800]	[1065]
	15,1	9	19	29	35	50	60	70	80	90	120
	254	254	251	249	246	241	236	230	224	193	
[6]	[73]	[161]	[252]	[303]	[439]	[529]	[618]	[709]	[802]	[1069]	
22,7	8	18	28	34	50	60	70	80	91	121	
	381	381	380	377	373	368	364	358	349	319	
[8]	[64]	[151]	[243]	[294]	[428]	[519]	[609]	[701]	[794]	[1076]	
30,3	7	17	27	33	48	59	69	79	90	122	
	508	508	508	504	500	496	491	484	476	446	
[10]	[57]	[141]	[234]	[283]	[419]	[512]	[602]	[693]	[786]	[1071]	
37,9	6	16	26	32	47	58	68	78	89	121	
	635	635	634	630	626	621	614	608	601	571	
[12]	[45]	[131]	[227]	[274]	[409]	[505]	[593]	[684]	[778]	[1058]	
45,4	5	15	26	31	46	57	67	77	88	120	
	762	762	762	757	753	747	741	734	728	694	
[14]	[33]	[118]	[213]	[266]	[396]	[492]	[583]	[676]	[770]	[1055]	
53,0	4	13	24	30	45	56	66	76	87	119	
	889	889	887	882	877	872	866	860	851	813	
[15]	[29]	[111]	[205]	[260]	[389]	[486]	[576]	[670]	[765]	[1055]	
56,8	3	13	23	29	44	55	65	76	86	119	
	953	953	951	945	940	935	929	921	913	872	
Max. Inter-mittent	[20]	[17]	[98]	[192]	[252]	[377]	[475]	[567]	[660]	[757]	
	75,7	2	11	22	28	43	54	64	75	86	
		1080	1080	1077	1071	1067	1062	1055	1049	1040	

74 cm<sup>3</sup>/r [4.5 in<sup>3</sup>/r]  
Δ Pressure Bar [PSI]

		[200]	[400]	[600]	[800]	[1000]	[1200]	[1400]	[1600]	[1800]	[2400]
		14	28	41	55	69	83	97	110	124	165
Flow LPM [GPM]	[2]	[103]	[220]	[339]	[454]	[569]	[685]	[801]	[916]	[1036]	[1373]
	7,6	12	25	38	51	64	77	91	103	117	155
		101	99	98	96	93	90	86	81	76	51
	[4]	[99]	[219]	[335]	[457]	[574]	[689]	[808]	[925]	[1042]	[1386]
	15,1	11	25	38	52	65	78	91	105	118	157
	203	201	199	197	194	191	187	182	177	153	
[6]	[94]	[210]	[328]	[451]	[571]	[689]	[805]	[924]	[1044]	[1392]	
22,7	11	24	37	51	65	78	91	104	118	157	
	305	303	301	298	296	292	288	283	276	252	
[8]	[86]	[196]	[319]	[438]	[558]	[676]	[793]	[913]	[1033]	[1401]	
30,3	10	22	36	49	63	76	90	103	117	158	
	406	404	402	399	396	393	388	383	377	352	
[10]	[74]	[183]	[310]	[422]	[545]	[667]	[784]	[903]	[1024]	[1394]	
37,9	8	21	35	48	62	75	89	102	116	158	
	507	505	502	499	496	492	486	482	476	452	
[12]	[58]	[171]	[295]	[408]	[533]	[657]	[773]	[891]	[1013]	[1377]	
45,4	7	19	33	46	60	74	87	101	114	156	
	608	606	603	600	596	591	587	581	576	549	
[14]	[43]	[154]	[277]	[396]	[515]	[640]	[760]	[880]	[1002]	[1374]	
53,0	5	17	31	45	58	72	86	99	113	155	
	709	706	702	698	694	691	686	681	674	643	
[15]	[36]	[145]	[268]	[387]	[506]	[632]	[750]	[873]	[996]	[1373]	
56,8	4	16	30	44	57	71	85	99	113	155	
	760	757	753	749	744	740	735	729	723	690	
Max. Inter-mittent	[20]	[14]	[121]	[233]	[351]	[482]	[609]	[725]	[856]	[981]	
	75,7	2	14	26	40	54	69	82	97	111	
		904	902	898	895	891	887	882	877	869	

Performance data is typical at 120 SUS. Actual data may vary slightly from unit to unit in production

# Performance Data H Series

Motors run with high efficiency in all areas designated with a number for torque and speed, however for best motor life select a motor to run with a torque and speed range shown in the light blue area.

		97 cm <sup>3</sup> /r [5.9 in <sup>3</sup> /r] Δ Pressure Bar [PSI] Continuous										Max. Continuous	Max. Intermittent
		[200]	[400]	[600]	[800]	[1000]	[1200]	[1400]	[1600]	[1800]	[2400]		
		14	28	41	55	69	83	97	110	124	165		
Flow LPM [GPM]	[2]	[134]	[292]	[442]	[593]	[746]	[899]	[1054]	[1209]	[1365]	[1806]		
	7.6	15 78	33 76	50 75	67 73	84 71	102 68	119 65	137 61	154 55	204 33		
	[4]	[131]	[281]	[436]	[596]	[750]	[903]	[1059]	[1212]	[1367]	[1828]		
	15.1	15 156	32 155	49 153	67 151	85 149	102 147	120 143	137 139	154 134	207 113		
	[6]	[126]	[269]	[425]	[588]	[747]	[900]	[1054]	[1206]	[1368]	[1823]		
	22.7	14 234	30 233	48 231	66 230	84 228	102 224	119 221	136 217	155 210	206 189		
	[8]	[110]	[246]	[408]	[566]	[718]	[873]	[1023]	[1177]	[1339]	[1829]		
	30.3	12 312	28 311	46 310	64 308	81 305	99 303	116 300	133 295	151 291	207 269		
	[10]	[96]	[231]	[392]	[539]	[699]	[859]	[1005]	[1156]	[1318]	[1821]		
	37.9	9 390	26 389	44 387	61 385	79 383	97 380	114 376	131 373	149 368	206 346		
[12]	[77]	[218]	[378]	[522]	[681]	[844]	[990]	[1142]	[1301]	[1792]			
45.4	9 468	25 467	43 465	59 463	77 460	95 457	112 453	129 449	147 445	202 421			
[14]	[60]	[197]	[358]	[513]	[662]	[828]	[973]	[1131]	[1293]	[1776]			
53.0	7 546	22 544	40 542	58 539	75 537	94 535	110 531	128 526	146 521	201 499			
Max. Continuous	[15]	[52]	[189]	[346]	[495]	[651]	[819]	[963]	[1126]	[1286]	[1778]		
	56.8	6 585	21 581	39 581	56 575	74 575	93 573	109 569	127 564	145 559	201 536		
Max. Intermittent	[20]	[25]	[157]	[311]	[455]	[625]	[790]	[941]	[1110]	[1272]			
	75.7	3 701	18 700	35 697	51 694	71 691	89 688	106 684	125 681	144 674			

		120 cm <sup>3</sup> /r [7.3 in <sup>3</sup> /r] Δ Pressure Bar [PSI] Continuous										Max. Continuous	Max. Intermittent
		[200]	[400]	[600]	[800]	[1000]	[1200]	[1400]	[1600]	[1800]	[2400]		
		14	28	41	55	69	83	97	110	124	165		
Flow LPM [GPM]	[2]	[162]	[357]	[544]	[736]	[927]	[1116]	[1305]	[1498]	[1687]	[2231]		
	7.6	18 62	40 61	61 61	83 59	105 58	126 55	149 53	169 49	191 45	252 26		
	[4]	[160]	[348]	[539]	[736]	[930]	[1119]	[1316]	[1506]	[1698]	[2268]		
	15.1	18 125	39 124	61 123	83 121	105 120	126 119	149 116	170 114	192 110	256 90		
	[6]	[155]	[338]	[530]	[729]	[923]	[1116]	[1310]	[1500]	[1699]	[2271]		
	22.7	18 188	38 187	60 186	82 185	104 183	126 180	148 175	169 170	192 170	257 152		
	[8]	[139]	[319]	[515]	[710]	[901]	[1094]	[1283]	[1476]	[1673]	[2278]		
	30.3	16 250	36 250	58 249	80 247	102 245	124 243	145 241	167 237	189 233	257 216		
	[10]	[121]	[303]	[497]	[686]	[883]	[1081]	[1267]	[1460]	[1655]	[2268]		
	37.9	14 313	34 312	56 311	78 309	100 308	122 306	143 302	165 300	187 296	256 278		
[12]	[102]	[288]	[480]	[664]	[862]	[1060]	[1246]	[1440]	[1640]	[2232]			
45.4	12 375	33 374	54 373	75 371	97 370	120 367	141 365	163 361	185 358	252 338			
[14]	[78]	[263]	[458]	[652]	[841]	[1041]	[1228]	[1420]	[1616]	[2213]			
53.0	9 438	30 437	52 435	74 433	95 431	118 430	139 427	160 423	183 419	250 401			
Max. Continuous	[15]	[67]	[253]	[446]	[632]	[828]	[1030]	[1214]	[1411]	[1608]	[2205]		
	56.8	8 469	29 468	50 466	71 464	94 462	116 460	137 458	159 454	182 450	249 430		
Max. Intermittent	[20]	[20]	[202]	[384]	[581]	[778]	[971]	[1169]	[1356]	[1559]			
	75.7	2 626	23 624	43 621	66 618	88 617	110 614	132 611	153 609	176 606			

		146 cm <sup>3</sup> /r [8.9 in <sup>3</sup> /r] Δ Pressure Bar [PSI] Continuous										Max. Continuous	Max. Intermittent
		[200]	[400]	[600]	[800]	[1000]	[1200]	[1400]	[1600]	[1700]	[2300]		
		14	28	41	55	69	83	97	110	117	159		
Flow LPM [GPM]	[2]	[198]	[435]	[664]	[897]	[1130]	[1361]	[1591]	[1827]	[1942]	[2611]		
	7.6	22 51	49 50	75 50	101 49	128 47	154 45	180 43	206 40	219 39	295 24		
	[4]	[196]	[424]	[657]	[898]	[1133]	[1365]	[1604]	[1836]	[1954]	[2648]		
	15.1	22 103	48 102	74 101	101 99	128 99	154 97	181 95	207 93	221 92	299 78		
	[6]	[189]	[412]	[646]	[889]	[1125]	[1361]	[1598]	[1829]	[1951]	[2653]		
	22.7	21 154	47 153	73 152	100 151	127 150	154 148	181 146	207 143	220 141	300 128		
	[8]	[169]	[389]	[628]	[866]	[1098]	[1333]	[1564]	[1799]	[1919]	[2649]		
	30.3	19 205	44 205	71 204	98 203	124 201	151 200	177 197	203 195	217 193	299 180		
	[10]	[148]	[369]	[605]	[836]	[1076]	[1318]	[1544]	[1780]	[1899]	[2789]		
	37.9	17 257	42 256	68 255	94 253	122 252	149 251	174 248	201 246	215 244	315 231		
[12]	[125]	[351]	[586]	[810]	[1051]	[1293]	[1519]	[1756]	[1878]	[2606]			
45.4	14 308	40 307	66 306	92 305	119 303	146 301	172 299	198 296	212 295	294 281			
[14]	[95]	[321]	[558]	[795]	[1026]	[1290]	[1497]	[1731]	[1851]	[2580]			
53.0	11 359	36 358	63 357	90 355	116 354	146 352	169 350	196 347	209 346	292 331			
Max. Continuous	[15]	[82]	[308]	[544]	[771]	[1010]	[1256]	[1480]	[1720]	[1840]	[2569]		
	56.8	9 385	35 384	61 383	87 381	114 379	142 378	167 375	194 373	208 371	290 356		
Max. Intermittent	[20]	[24]	[246]	[468]	[708]	[948]	[1184]	[1425]	[1653]	[1780]			
	75.7	3 513	28 512	53 509	80 507	107 506	134 504	161 501	187 499	201 498			

		159 cm <sup>3</sup> /r [9.7 in <sup>3</sup> /r] Δ Pressure Bar [PSI] Continuous										Max. Continuous	Max. Intermittent
		[200]	[400]	[600]	[800]	[1000]	[1200]	[1400]	[1600]	[1650]	[2300]		
		14	28	41	55	69	83	97	110	134	155		
Flow LPM [GPM]	[2]	[209]	[465]	[715]	[973]	[1228]	[1478]	[1724]	[1981]	[2046]	[2764]		
	7.6	24 47	53 46	81 46	110 45	139 44	167 42	197 40	226 38	231 37	312 23		
	[4]	[210]	[460]	[710]	[971]	[1229]	[1480]	[1745]	[1996]	[2059]	[2813]		
	15.1	24 94	52 94	80 93	110 91	139 91	167 90	197 89	226 87	233 87	318 76		
	[6]	[205]	[454]	[704]	[965]	[1216]	[1477]	[1738]	[1991]	[2055]	[2824]		
	22.7	23 141	51 141	80 140	109 139	137 136	167 136	196 132	225 132	232 132	319 119		
	[8]	[186]	[440]	[693]	[951]	[1205]	[1461]	[1716]	[1973]	[2038]	[2808]		
	30.3	21 188	50 188	78 187	107 186	136 185	165 183	194 181	223 179	230 178	317 166		
	[10]	[164]	[422]	[671]	[930]	[1189]	[1451]	[1702]	[1965]	[2032]	[2789]		
	37.9	19 235	48 234	76 234	105 232	134 232	164 230	192 228	219 226	230 225	315 213		
[12]	[144]	[404]	[652]	[900]	[1163]	[1421]	[1674]	[1937]	[2004]	[2770]			
45.4	16 282	46 281	74 281	102 279	131 279	161 277	189 275	219 273	226 272	313 260			
[14]	[109]	[374]	[623]	[883]	[1140]	[1396]	[1653]	[1900]	[1963]	[2727]			
53.0	12 330	42 329	70 328	100 327	129 325	158 323	187 322	215 319	222 319	308 306			
Max. Continuous	[15]	[92]	[359]	[612]	[861]	[1123]	[1381]	[1633]	[1886]	[1950]	[2712]		
	56.8	10 353	41 352	69 351	97 350	127 348	156 347	185 345	213 343	220 342	306 330		
Max. Intermittent	[20]	[26]	[268]	[510]	[772]	[1034]	[1290]	[1553]	[1802]	[1865]			
	75.7	3 471	30 470	58 467	87 465	117 464	146 462	175 460	204 458	211 458			

[359]  
41 } Torque [lb-in]  
352 } Nm  
Speed RPM

Performance data is typical at 120 SUS. Actual data may vary slightly from unit to unit in production

# Performance Data H Series

Motors run with high efficiency in all areas designated with a number for torque and speed, however for best motor life select a motor to run with a torque and speed range shown in the light blue area.

185 cm <sup>3</sup> /r [11.3 in <sup>3</sup> /r] Δ Pressure Bar [PSI] Continuous												Max. Continuous	Max. Inter-mittent	231 cm <sup>3</sup> /r [14.1 in <sup>3</sup> /r] Δ Pressure Bar [PSI] Continuous												Max. Continuous	Max. Inter-mittent				
[200]	[400]	[600]	[800]	[1000]	[1200]	[1400]	[1600]	[2150]	[200]	[400]	[600]	[800]	[1000]	[1200]	[1400]	[1450]	[2000]			[200]	[400]	[600]	[800]	[1000]	[1200]	[1400]	[1450]	[2000]			
14	28	41	55	69	83	97	110	148	14	28	41	55	69	83	97	100	138			14	28	41	55	69	83	97	100	138			
[2]	[257]	[554]	[847]	[1150]	[1447]	[1739]	[2035]	[2320]	[2]	[338]	[707]	[1074]	[1456]	[1827]	[2192]	[2572]	[2657]				[2]	[338]	[707]	[1074]	[1456]	[1827]	[2192]	[2572]	[2657]		
7.6	29	63	96	130	163	196	230	262	7.6	32	80	121	165	206	248	291	300			7.6	32	80	121	165	206	248	291	300			
[4]	[254]	[546]	[845]	[1145]	[1448]	[1744]	[2049]	[2343]	[4]	[328]	[695]	[1076]	[1447]	[1827]	[2201]	[2577]	[2669]	[3671]			[4]	[328]	[695]	[1076]	[1447]	[1827]	[2201]	[2577]	[2669]	[3671]	[415]
15.1	29	62	95	129	164	197	232	265	15.1	37	79	122	163	206	249	291	302			15.1	37	79	122	163	206	249	291	302			
[6]	[246]	[540]	[834]	[1137]	[1434]	[1736]	[2036]	[2337]	[6]	[317]	[687]	[1057]	[1434]	[1811]	[2186]	[2555]	[2650]	[3668]			[6]	[317]	[687]	[1057]	[1434]	[1811]	[2186]	[2555]	[2650]	[3668]	[414]
22.7	28	61	94	128	162	196	230	264	22.7	36	78	119	162	205	247	289	299			22.7	36	78	119	162	205	247	289	299			
[8]	[224]	[520]	[820]	[1117]	[1414]	[1716]	[2014]	[2315]	[8]	[289]	[659]	[1038]	[1406]	[1777]	[2160]	[2531]	[2625]	[3644]			[8]	[289]	[659]	[1038]	[1406]	[1777]	[2160]	[2531]	[2625]	[3644]	[412]
30.3	25	59	93	126	160	194	228	262	30.3	33	74	117	159	201	244	286	297			30.3	33	74	117	159	201	244	286	297			
[10]	[202]	[499]	[793]	[1095]	[1394]	[1699]	[1997]	[2299]	[10]	[265]	[631]	[1004]	[1381]	[1751]	[2131]	[2510]	[2602]	[3608]			[10]	[265]	[631]	[1004]	[1381]	[1751]	[2131]	[2510]	[2602]	[3608]	[408]
37.9	23	56	90	124	158	192	226	260	37.9	30	71	113	156	198	241	284	294			37.9	30	71	113	156	198	241	284	294			
[12]	[176]	[475]	[767]	[1063]	[1368]	[1664]	[1969]	[2268]	[12]	[230]	[599]	[968]	[1345]	[1722]	[2088]	[2480]	[2571]	[3571]			[12]	[230]	[599]	[968]	[1345]	[1722]	[2088]	[2480]	[2571]	[3571]	[403]
45.4	20	54	87	120	155	188	222	256	45.4	26	68	109	152	195	236	280	290			45.4	26	68	109	152	195	236	280	290			
[14]	[140]	[443]	[735]	[1035]	[1340]	[1637]	[1936]	[2227]	[14]	[191]	[563]	[927]	[1299]	[1686]	[2058]	[2428]	[2519]	[3532]			[14]	[191]	[563]	[927]	[1299]	[1686]	[2058]	[2428]	[2519]	[3532]	[399]
53.0	16	50	83	117	151	185	219	252	53.0	22	64	105	147	190	233	274	285			53.0	22	64	105	147	190	233	274	285			
[15]	[120]	[425]	[719]	[1014]	[1320]	[1618]	[1914]	[2205]	[15]	[167]	[538]	[904]	[1279]	[1661]	[2030]	[2404]	[2493]	[3488]			[15]	[167]	[538]	[904]	[1279]	[1661]	[2030]	[2404]	[2493]	[3488]	[394]
56.8	14	48	81	115	149	183	217	249	56.8	19	61	102	145	188	229	272	282			56.8	19	61	102	145	188	229	272	282			
[20]	[27]	[321]	[612]	[911]	[1211]	[1504]	[1795]		[20]	[29]	[411]	[785]	[1152]	[1520]	[1877]	[2222]	[2318]				[20]	[29]	[411]	[785]	[1152]	[1520]	[1877]	[2222]	[2318]		
75.7	3	36	69	103	137	170	203		75.7	3	46	89	130	172	212	251	262			75.7	3	46	89	130	172	212	251	262			

293 cm <sup>3</sup> /r [17.9 in <sup>3</sup> /r] Δ Pressure Bar [PSI] Continuous										Max. Continuous	Max. Inter-mittent	370 cm <sup>3</sup> /r [22.6 in <sup>3</sup> /r] Δ Pressure Bar [PSI] Continuous										Max. Continuous	Max. Inter-mittent												
[200]	[400]	[600]	[800]	[1000]	[1200]	[1350]	[1800]	[200]	[400]	[600]	[800]	[1000]	[1200]	[1250]	[1500]	[200]	[400]	[600]	[800]			[200]	[400]	[600]	[800]	[1000]	[1200]	[1250]	[1500]	[200]	[400]	[600]	[800]		
14	28	41	55	69	83	93	124	14	28	41	55	69	83	86	103	14	28	41	55	69	83	86	103			14	28	41	55	69	83	86	103		
[2]	[427]	[893]	[1361]	[1829]	[2293]	[2672]	[2977]		[2]	[537]	[1121]	[1715]	[2285]	[2862]								[2]	[537]	[1121]	[1715]	[2285]	[2862]								
7.6	48	101	154	207	259	302	336	7.6	61	127	194	258	323									7.6	61	127	194	258	323								
[4]	[419]	[886]	[1362]	[1833]	[2305]	[2771]	[3110]	[4107]	[4]	[532]	[1123]	[1715]	[2308]	[2893]	[3467]	[3604]	[4274]					[4]	[532]	[1123]	[1715]	[2308]	[2893]	[3467]	[3604]	[4274]				[4600]	[520]
15.1	47	100	154	207	260	312	351	15.1	60	127	194	261	327	392	407						15.1	60	127	194	261	327	392	407							
[6]	[402]	[872]	[1342]	[1819]	[2291]	[2757]	[3098]	[4121]	[6]	[508]	[1100]	[1693]	[2294]	[2884]	[3458]	[3598]	[4283]					[6]	[508]	[1100]	[1693]	[2294]	[2884]	[3458]	[3598]	[4283]				[4590]	[519]
22.7	45	99	152	206	259	312	350	22.7	57	124	191	259	326	391	407						22.7	57	124	191	259	326	391	407							
[8]	[367]	[838]	[1316]	[1785]	[2252]	[2723]	[3070]	[4086]	[8]	[463]	[1060]	[1661]	[2255]	[2840]	[3414]	[3557]	[4254]					[8]	[463]	[1060]	[1661]	[2255]	[2840]	[3414]	[3557]	[4254]				[4515]	[510]
30.3	41	95	149	202	254	306	347	30.3	52	120	188	255	321	386	402						30.3	52	120	188	255	321	386	402							
[10]	[332]	[803]	[1276]	[1749]	[2215]	[2684]	[3034]	[4061]	[10]	[414]	[1017]	[1613]	[2203]	[2788]	[3363]	[3506]	[4212]					[10]	[414]	[1017]	[1613]	[2203]	[2788]	[3363]	[3506]	[4212]				[4430]	[501]
37.9	38	91	144	198	250	303	343	37.9	47	115	182	249	315	380	396						37.9	47	115	182	249	315	380	396							
[12]	[289]	[760]	[1230]	[1706]	[2177]	[2634]	[2989]	[4012]	[12]	[363]	[960]	[1553]	[2152]	[2737]	[3305]	[3446]	[4152]					[12]	[363]	[960]	[1553]	[2152]	[2737]	[3305]	[3446]	[4152]				[4320]	[488]
45.4	33	86	139	193	246	298	338	45.4	41	108	175	243	309	373	389						45.4	41	108	175	243	309	373	389							
[14]	[241]	[712]	[1176]	[1650]	[2126]	[2592]	[2935]	[3963]	[14]	[303]	[897]	[1484]	[2086]	[2667]	[3246]	[3386]	[4092]					[14]	[303]	[897]	[1484]	[2086]	[2667]	[3246]	[3386]	[4092]				[4195]	[474]
53.0	27	80	133	186	240	293	332	53.0	34	101	168	236	301	367	383						53.0	34	101	168	236	301	367	383							
[15]	[211]	[683]	[1149]	[1623]	[2096]	[2558]	[2905]	[3914]	[15]	[266]	[862]	[1452]	[2050]	[2630]	[3206]	[3347]	[4054]					[15]	[266]	[862]	[1452]	[2050]	[2630]	[3206]	[3347]	[4054]				[4130]	[467]
56.8	24	77	130	183	237	289	328	56.8	30	97	164	232	297	362	378						56.8	30	97	164	232	297	362	378							
[20]	[43]	[527]	[1001]	[1463]	[1919]	[2375]	[2720]		[20]	[61]	[671]	[1269]	[1847]	[2410]	[2987]	[3119]						[20]	[61]	[671]	[1269]	[1847]	[2410]	[2987]	[3119]						
75.7	5	60	113	165	217	268	307		75.7	7	76	143	209	272	337	352						75.7	7	76	143	209	272	337	352						

[862]  
97 } Torque [lb-in]  
152 } Nm  
Speed RPM

Performance data is typical at 120 SUS. Actual data may vary slightly from unit to unit in production

# Dimensions H Series

## 2 Bolt Flange

82,55/82,42  
[3.250/3.245]  
Pilot Dia.

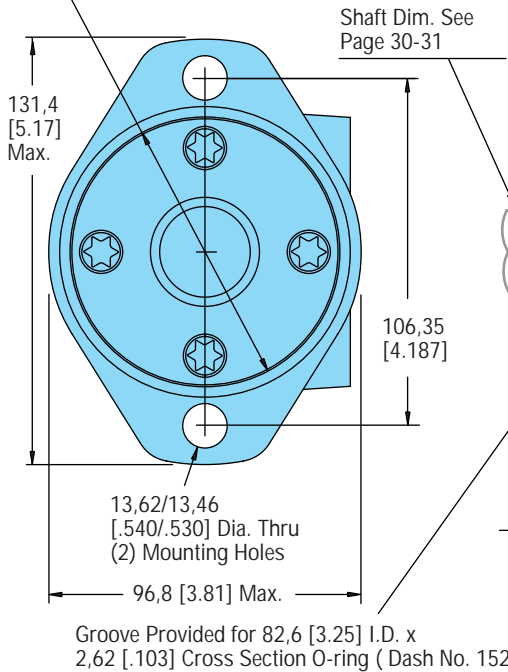

Standard Rotation  
Viewed from Shaft End  
Port A Pressurized — CW  
Port B Pressurized — CCW

## 4 Bolt Flange

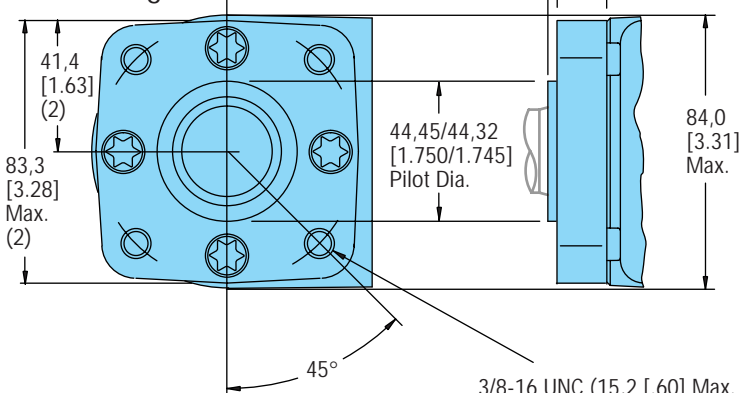

3/8-16 UNC (15,2 [.60] Max. Bolt Thread Engagement ) Mounting Holes (4) Equally Spaced on 82,6 [3.25] Dia. Bolt Circle or M10 x 1,5 (15,2 [.60] Max. Bolt Thread Engagement ) Mounting Holes (4) Equally Spaced on 82,6 [3.25] Dia. Bolt Circle

## End Ported Motor End Cap

See Page 33

End Ported End Cap  
with Case Drain Port  
See Page 34

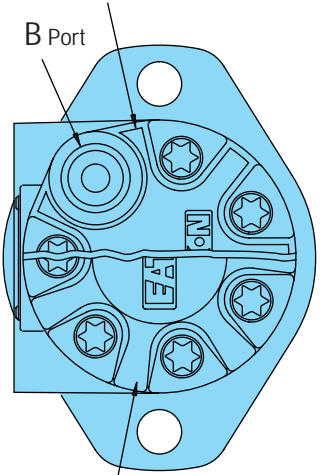

## Standard Motor End Cap

End Cap with Case Drain Port  
See Page 34

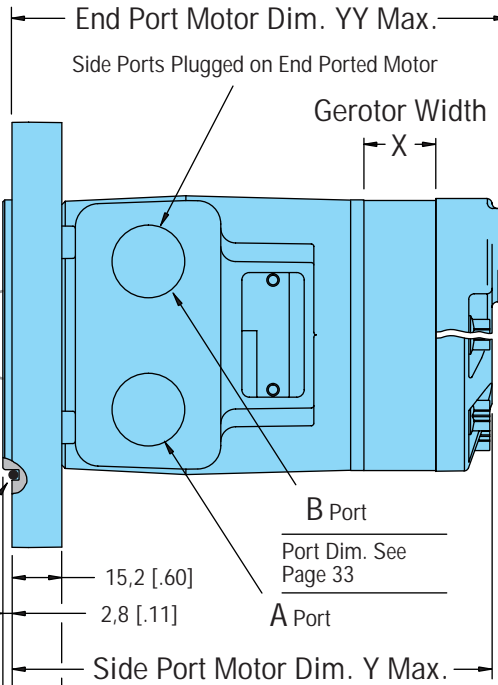

Displ. cm <sup>3</sup> /r [in <sup>3</sup> /r]	X	Y Max.	YY Max.
	Width mm [in.]	Length mm [in.]	Length mm [in.]
36 [ 2.2]	6,4 [ .25]	132,1 [5.20]	138,5 [5.45]
46 [ 2.8]	6,4 [ .25]	132,1 [5.20]	138,5 [5.45]
59 [ 3.6]	10,2 [ .40]	135,9 [5.35]	142,3 [5.60]
74 [ 4.5]	10,2 [ .40]	135,9 [5.35]	142,3 [5.60]
97 [ 5.9]	13,2 [ .52]	139,0 [5.47]	145,3 [5.72]
120 [ 7.3]	16,5 [ .65]	142,3 [5.60]	148,6 [5.85]
146 [ 8.9]	20,1 [ .79]	145,8 [5.74]	152,2 [5.99]
159 [ 9.7]	21,9 [ .86]	147,6 [5.81]	154,0 [6.06]
185 [11.3]	25,4 [1.00]	151,2 [5.95]	157,5 [6.20]
231 [14.1]	31,8 [1.25]	157,5 [6.20]	
293 [17.9]	40,4 [1.59]	166,2 [6.54]	
370 [22.6]	50,8 [2.00]	176,6 [6.95]	
739 [45.1]	101,6 [4.00]	227,4 [8.95]	

Note: Mounting Surface Flatness Requirement is ,13 mm [.005 inch] Max.

# Product Numbers

## H Series 101-xxxx

### Product Numbers—H Series

Add three digit prefix —101—to four digit number from chart for complete product number—Example 101-1868.  
Orders will not be accepted without three digit prefix.

Mounting	Shaft	Ports	Displ. cm <sup>3</sup> /r [in <sup>3</sup> /r] Product Number 101-xxxx												
			36 [ 2.2]	46 [ 2.8]	59 [ 3.6]	74 [ 4.5]	97 [ 5.9]	120 [ 7.3]	146 [ 8.9]	159 [ 9.7]	185 [11.3]	231 [14.1]	293 [17.9]	370 [22.6]	740 [45.0]
2 Bolt Flange	1 in. Straight w/Woodruff Key	7/8-14 O-ring	101-1700	-1033	-1701	-1034	-1035	-1702	-1703	-1036	-1037	-1038	-1039	-1040	—
		1/2 NPTF	101-1704	-1025	-1705	-1026	-1027	-1706	-1707	-1028	-1029	-1030	-1031	-1032	—
		Manifold*	101-1708	-1041	-1709	-1042	-1043	-1710	-1711	-1044	-1045	-1046	-1047	-1048	—
	1 in. SAE 6B Splined	7/8-14 O-ring	101-1721	-1081	-1722	-1082	-1083	-1723	-1724	-1084	-1085	-1086	-1087	-1088	—
		1/2 NPTF	101-1725	-1073	-1726	-1074	-1075	-1727	-1728	-1076	-1077	-1078	-1079	-1080	—
		Manifold*	101-1729	-1089	-1730	-1090	-1091	-1731	-1732	-1092	-1093	-1094	-1095	-1096	—
	1 in. Straight w/.31 Dia. Crosshole	7/8-14 O-ring	101-1796	-1797	-1798	-1799	-1800	-1801	-1802	-1803	—	—	—	—	—
		1/2 NPTF	101-1804	-1805	-1806	-1807	-1808	-1870	-1809	-1810	—	—	—	—	—
		Manifold*	101-1811	-1812	-1813	-1814	-1815	-1816	-1817	-1818	—	—	—	—	—
	1 in. Straight w/.40 Dia. Crosshole	7/8-14 O-ring	101-1819	-1323	-1820	-1324	-1325	-1821	-1822	-1326	—	—	—	—	—
		1/2 NPTF	101-1823	-1319	-1824	-1320	-1825	-1826	-1827	-1828	—	—	—	—	—
		Manifold*	101-1829	-1463	-1830	-1831	-1832	-1833	-1834	-1871	—	—	—	—	—
4 Bolt Flange	1 in. Straight w/Woodruff Key	7/8-14 O-ring	101-1749	-1009	-1750	-1010	-1011	-1751	-1752	-1012	-1013	-1014	-1015	-1016	—
		1/2 NPTF	101-1753	-1001	-1754	-1002	-1003	-1755	-1756	-1004	-1005	-1006	-1007	-1008	—
		Manifold*	101-1757	-1017	-1758	-1018	-1019	-1759	-1760	-1020	-1021	-1022	-1023	-1024	—
	1 in. SAE 6B Splined	7/8-14 O-ring	101-1761	-1057	-1762	-1058	-1059	-1872	-1763	-1060	-1061	-1062	-1063	-1064	—
		1/2 NPTF	101-1764	-1049	-1765	-1050	-1051	-1766	-1767	-1052	-1053	-1054	-1055	-1056	—
		Manifold*	101-1768	-1065	-1769	-1066	-1067	-1770	-1771	-1068	-1069	-1070	-1071	-1072	—
	1 in. Straight w/.31 Dia. Crosshole	7/8-14 O-ring	101-1835	-1836	-1837	-1838	-1839	-1840	-1841	-1842	—	—	—	—	—
		1/2 NPTF	101-1843	-1497	-1844	-1449	-1352	-1845	-1846	-1847	—	—	—	—	—
		Manifold*	101-1848	-1466	-1849	-1459	-1850	-1851	-1852	-1853	—	—	—	—	—
	1 in. Straight w/.40 Dia. Crosshole	7/8-14 O-ring	101-1854	-1311	-1855	-1856	-1857	-1858	-1859	-1860	—	—	—	—	—
		1/2 NPTF	101-1861	-1313	-1862	-1312	-1314	-1863	-1864	-1315	—	—	—	—	—
		Manifold*	101-1865	-1305	-1866	-1306	-1307	-1867	-1868	-1869	—	—	—	—	—

101-1868

### Product Numbers—H Series Motors with Corrosion Protection

Mounting	Shaft	Ports	Displ. cm <sup>3</sup> /r [in <sup>3</sup> /r] Product Number 101-xxxx												
			36 [ 2.2]	46 [ 2.8]	59 [ 3.6]	74 [ 4.5]	97 [ 5.9]	120 [ 7.3]	146 [ 8.9]	159 [ 9.7]	185 [11.3]	231 [14.1]	293 [17.9]	370 [22.6]	740 [45.0]
4 Bolt Flange	1 in. Straight w/Woodruff Key	1/2 NPTF	101-2032	-2014	-2093	-2027	-2013	-2094	-2095	-2015	-2028	-2029	-2030	-2031	—
		Manifold*		-2067							-2068	-2069			

\*Manifold product numbers shown are for motors with four 5/16-18 port face mounting threads. Manifold, manifold mounting o-rings and bolts are NOT included (for M8 x 1,5 port face mounting threads see note below).

For H Series Motors with a configuration *Not Shown* in the charts above: Use the model code number system on page 37 to specify the product in detail.

For H Series Motors with Low Speed Valving — See Page 28.

# Specifications S Series

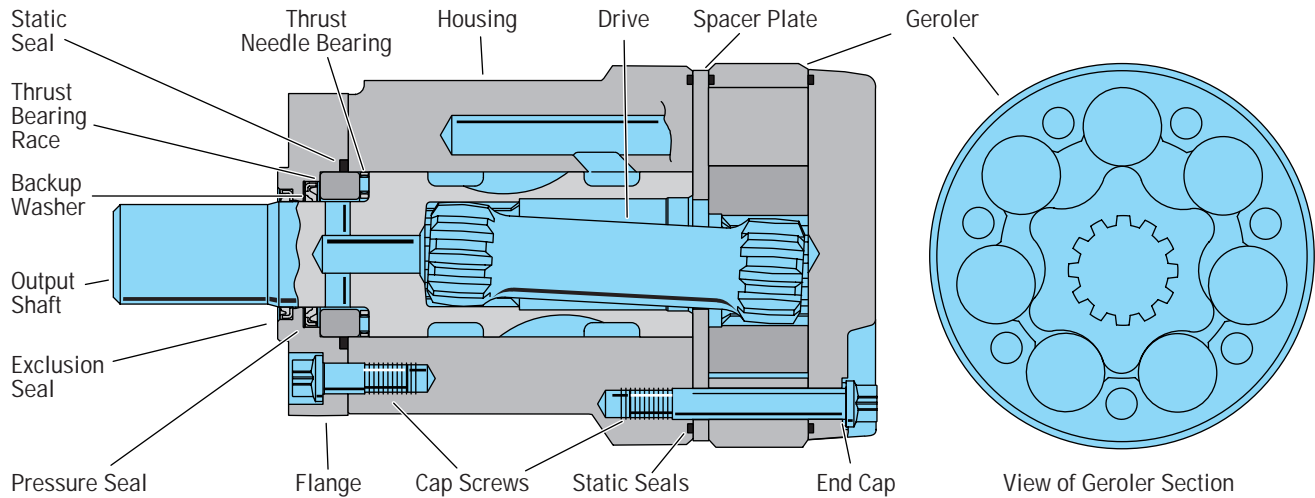

## Specification Data—S Series

Displ. cm <sup>3</sup> /r [cu. in <sup>3</sup> /r]		59 [ 3.6]	74 [ 4.5]	97 [ 5.9]	120 [ 7.3]	146 [ 8.9]	159 [ 9.7]	185 [11.3]	231 [14.1]	293 [17.9]	370 [22.6]
Max. Speed (RPM) @ Continuous Flow		962	762	585	470	385	353	303	243	192	153
Flow LPM [GPM]	Continuous	57 [15]	57 [15]	57 [15]	57 [15]	57 [15]	57 [15]	57 [15]	57 [15]	57 [15]	57 [15]
	Intermittent	68 [18]	76 [20]	76 [20]	76 [20]	76 [20]	76 [20]	76 [20]	76 [20]	76 [20]	76 [20]
Torque Nm [lb-in]	Continuous	107 [ 943]	139 [1228]	181 [1591]	227 [2010]	263 [2332]	291 [2567]	324 [2870]	369 [3265]	411 [3641]	452 [4004]
	Intermittent **	133 [1174]	173 [1529]	225 [1991]	281 [2490]	323 [2861]	347 [3072]	390 [3450]	438 [3877]	485 [4295]	514 [4548]
Min. Starting Torque Nm[lb-in]	@ Cont. Pressure	90 [ 800]	113 [1000]	148 [1310]	184 [1630]	212 [1880]	232 [2050]	263 [2330]	302 [2670]	338 [2990]	369 [3270]
	@ Int. Pressure	116 [1030]	146 [1290]	190 [1680]	236 [2090]	271 [2400]	289 [2560]	329 [2910]	374 [3310]	417 [3690]	438 [3880]
Pressure Δ Bar [Δ PSI]	Continuous*	138 [2000]	138 [2000]	138 [2000]	138 [2000]	131 [1900]	131 [1900]	128 [1850]	117 [1700]	103 [1500]	90 [1300]
	Intermittent**	172 [2500]	172 [2500]	172 [2500]	172 [2500]	162 [2350]	159 [2300]	155 [2250]	141 [2050]	124 [1800]	103 [1500]

Maximum Case Pressure - without Case Drain — 103 Bar [1500 PSI] — See Page 34-35

\* Maximum intermittent pressure at motor inlet port of 172 Bar [2500 PSI] without regard to Δ Bar [Δ PSI] and/or back pressure ratings or combination thereof.

\*\* A simultaneous maximum torque and maximum speed NOT recommended.

6B Splined or Tapered shafts are recommended whenever operating above 282 Nm [2500 lb-in] of torque, especially for those applications subject to frequent reversals (see page 30).

Δ Bar [Δ PSI] — True pressure difference between inlet port and outlet port.

Continuous Rating — Motor may be run continuously at these ratings.

Intermittent Operation — 10% of every minute.

Recommended Fluids — Premium quality, anti-wear type hydraulic oil with a viscosity of not less than 70 SUS at operating temperature.

Recommended Maximum System Operating Temp — Is 82° C [180° F]

Recommended Filtration — per ISO Cleanliness Code, level 18/13

To assure optimum motor life, run motor for approximately one hour at 30% of rated pressure before application to full load. Be sure motor is filled with fluid prior to any load applications.

# Performance Data S Series

Motors run with high efficiency in all areas designated with a number for torque and speed, however for best motor life select a motor to run with a torque and speed range shown in the light blue area.

59 cm<sup>3</sup>/r [3.6 in<sup>3</sup>/r]  
Δ Pressure Bar [PSI]  
Continuous

	[200]	[400]	[600]	[800]	[1000]	[1200]	[1400]	[1600]	[1800]	[2000]	[2500]
	14	28	41	55	69	83	97	110	124	138	172
[2]	[89]	[191]	[289]	[382]	[477]	[571]	[665]	[755]	[834]		
7,6	10	22	33	43	54	65	75	85	94		
[4]	[91]	[187]	[283]	[372]	[474]	[572]	[666]	[764]	[849]	[942]	
15,1	10	21	32	42	54	65	75	86	96	106	
[6]	[84]	[176]	[276]	[371]	[469]	[563]	[658]	[753]	[851]	[943]	[1174]
22,7	9	20	31	42	53	64	74	85	96	107	133
[8]	[75]	[168]	[269]	[364]	[456]	[556]	[657]	[752]	[846]	[939]	[1174]
30,3	8	19	30	41	52	63	74	85	96	106	133
[10]	[66]	[160]	[258]	[354]	[446]	[544]	[642]	[738]	[834]	[928]	[1167]
37,9	7	18	29	40	50	61	73	83	94	105	132
[12]	[54]	[147]	[247]	[345]	[441]	[537]	[633]	[728]	[823]	[920]	[1158]
45,4	6	17	28	39	50	61	72	82	93	104	131
[14]	[39]	[133]	[235]	[327]	[428]	[524]	[618]	[714]	[811]	[907]	[1145]
53,0	4	15	27	37	48	59	70	81	92	102	129
[15]	[29]	[125]	[228]	[321]	[422]	[519]	[613]	[708]	[805]	[901]	[1138]
56,8	3	14	26	36	48	59	69	80	91	102	129
[18]	[13]	[107]	[206]	[300]	[398]	[502]	[593]	[689]	[783]	[879]	
68,1	1	12	23	34	45	57	67	78	88	99	

74 cm<sup>3</sup>/r [4.5 in<sup>3</sup>/r]  
Δ Pressure Bar [PSI]  
Continuous

	[200]	[400]	[600]	[800]	[1000]	[1200]	[1400]	[1600]	[1800]	[2000]	[2500]
	14	28	41	55	69	83	97	110	124	138	172
[2]	[116]	[248]	[376]	[498]	[620]	[743]	[865]	[983]	[1086]		
7,6	13	28	42	56	70	84	98	111	123		
[4]	[119]	[244]	[369]	[484]	[618]	[744]	[867]	[995]	[1105]	[1227]	
15,1	13	28	42	55	70	84	98	112	125	139	
[6]	[109]	[229]	[359]	[483]	[611]	[733]	[857]	[981]	[1108]	[1228]	[1529]
22,7	12	26	41	55	69	83	97	111	125	139	173
[8]	[97]	[219]	[351]	[474]	[594]	[725]	[856]	[979]	[1104]	[1223]	[1529]
30,3	11	25	40	54	67	82	97	111	124	138	173
[10]	[86]	[209]	[335]	[461]	[580]	[709]	[836]	[961]	[1086]	[1209]	[1520]
37,9	10	24	38	52	66	80	94	109	123	137	172
[12]	[70]	[191]	[322]	[449]	[574]	[699]	[824]	[948]	[1072]	[1198]	[1508]
45,4	8	22	36	51	65	79	93	107	121	135	170
[14]	[51]	[173]	[307]	[425]	[558]	[682]	[805]	[930]	[1056]	[1181]	[1491]
53,0	6	20	35	48	63	77	91	105	119	133	168
[15]	[37]	[163]	[296]	[418]	[550]	[676]	[799]	[921]	[1048]	[1173]	[1482]
56,8	4	18	33	47	62	76	90	104	118	133	167
[20]	[18]	[89]	[242]	[369]	[528]	[645]	[762]	[884]	[1001]	[1117]	
75,7	2	10	27	42	60	73	86	100	113	126	

97 cm<sup>3</sup>/r [5.9 in<sup>3</sup>/r]  
Δ Pressure Bar [PSI]  
Continuous

	[200]	[400]	[600]	[800]	[1000]	[1200]	[1400]	[1600]	[1800]	[2000]	[2500]
	14	28	41	55	69	83	97	110	124	138	172
[2]	[152]	[324]	[490]	[649]	[808]	[968]	[1127]	[1280]	[1414]		
7,6	17	37	55	73	91	109	127	145	160		
[4]	[155]	[318]	[480]	[630]	[804]	[969]	[1129]	[1296]	[1439]	[1598]	
15,1	18	36	54	71	91	109	128	146	163	181	
[6]	[142]	[298]	[467]	[629]	[796]	[955]	[1116]	[1278]	[1443]	[1599]	[1991]
22,7	16	34	53	71	90	108	126	144	163	181	225
[8]	[126]	[285]	[457]	[618]	[774]	[943]	[1115]	[1274]	[1434]	[1593]	[1991]
30,3	14	32	52	70	87	107	126	144	162	180	225
[10]	[112]	[272]	[437]	[600]	[756]	[923]	[1089]	[1251]	[1414]	[1574]	[1979]
37,9	13	31	49	68	85	104	123	141	160	178	224
[12]	[92]	[249]	[419]	[584]	[748]	[910]	[1073]	[1235]	[1396]	[1560]	[1964]
45,4	10	28	47	66	85	103	121	140	158	176	222
[14]	[66]	[225]	[399]	[554]	[726]	[888]	[1049]	[1210]	[1375]	[1538]	[1941]
53,0	7	25	45	63	82	100	119	137	155	174	219
[15]	[49]	[213]	[386]	[544]	[716]	[880]	[1040]	[1200]	[1364]	[1527]	[1930]
56,8	6	24	44	61	81	99	118	136	154	173	218
[20]	[24]	[115]	[315]	[481]	[688]	[839]	[993]	[1151]	[1303]	[1455]	
75,7	3	13	36	54	78	95	112	130	147	164	

120 cm<sup>3</sup>/r [7.3 in<sup>3</sup>/r]  
Δ Pressure Bar [PSI]  
Continuous

	[200]	[400]	[600]	[800]	[1000]	[1200]	[1400]	[1600]	[1800]	[2000]	[2500]
	14	28	41	55	69	83	97	110	124	138	172
[2]	[190]	[403]	[608]	[814]	[1017]	[1214]	[1411]	[1598]	[1770]	[1947]	
7,6	21	46	69	92	115	137	159	181	200	220	
[4]	[192]	[400]	[606]	[803]	[1014]	[1221]	[1422]	[1627]	[1815]	[2008]	
15,1	22	45	68	91	115	138	161	184	205	227	
[6]	[178]	[380]	[591]	[798]	[1006]	[1209]	[1413]	[1615]	[1815]	[2010]	[2485]
22,7	20	43	67	90	114	137	160	182	205	227	281
[8]	[161]	[366]	[579]	[782]	[982]	[1193]	[1403]	[1605]	[1804]	[2003]	[2490]
30,3	18	41	65	88	111	135	159	181	204	226	281
[10]	[144]	[351]	[556]	[760]	[963]	[1172]	[1381]	[1579]	[1786]	[1984]	[2487]
37,9	16	40	63	86	109	132	156	178	202	224	281
[12]	[124]	[323]	[527]	[739]	[950]	[1153]	[1359]	[1561]	[1761]	[1966]	[2466]
45,4	14	36	60	83	107	130	154	176	199	222	279
[14]	[93]	[296]	[507]	[709]	[920]	[1123]	[1328]	[1532]	[1738]	[1940]	[2446]
53,0	11	33	57	80	104	127	150	173	196	219	276
[15]	[72]	[281]	[491]	[696]	[907]	[1110]	[1316]	[1519]	[1722]	[1928]	[2426]
56,8	8	32	55	79	102	125	149	172	195	218	274
[20]	[179]	[409]	[617]	[851]	[1047]	[1249]	[1448]	[1644]	[1837]		
75,7	20	46	70	96	118	141	164	186	208		

[281]  
32 } Torque [lb-in]  
468 } Nm  
Speed RPM

Performance data is typical at 120 SUS. Actual data may vary slightly from unit to unit in production

# Performance Data S Series

Motors run with high efficiency in all areas designated with a number for torque and speed, however for best motor life select a motor to run with a torque and speed range shown in the light blue area.

146 cm<sup>3</sup>/r [8.9 in<sup>3</sup>/r]  
Δ Pressure Bar [PSI]  
Continuous

	[200]	[400]	[600]	[800]	[1000]	[1200]	[1400]	[1600]	[1800]	[1900]	Max. Continuous	Max. Inter-mittent
	14	28	41	55	69	83	97	110	124	131	[2350]	162
[2]	[231]	[491]	[741]	[993]	[1239]	[1480]	[1720]	[1949]	[2159]	[2267]		
7.6	26	55	84	112	140	167	194	220	244	256		
	51	50	49	48	46	42	39	34	25	24		
[4]	[234]	[488]	[739]	[979]	[1237]	[1489]	[1734]	[1984]	[2212]	[2331]		
15.1	26	55	83	111	140	168	196	224	250	263		
	103	102	100	99	97	95	91	87	82	79		
[6]	[217]	[464]	[721]	[972]	[1227]	[1474]	[1722]	[1969]	[2213]	[2332]	[2859]	
22.7	25	52	81	110	139	167	195	222	250	263	323	
	154	153	152	150	148	145	142	137	130	126	105	
[8]	[196]	[447]	[706]	[954]	[1197]	[1454]	[1711]	[1956]	[2199]	[2321]	[2861]	
30.3	22	51	80	108	133	164	193	221	248	262	323	
	205	204	203	201	200	197	193	188	182	177	156	
[10]	[176]	[428]	[678]	[926]	[1174]	[1429]	[1684]	[1925]	[2178]	[2298]	[2841]	
37.9	20	48	77	105	133	161	190	217	246	260	321	
	257	256	255	253	251	247	244	239	232	229	207	
[12]	[151]	[394]	[643]	[902]	[1159]	[1405]	[1657]	[1903]	[2147]	[2271]	[2828]	
45.4	17	45	73	102	131	159	187	215	243	257	320	
	308	307	305	304	302	298	294	290	284	279	258	
[14]	[113]	[361]	[618]	[864]	[1121]	[1369]	[1619]	[1868]	[2118]	[2241]	[2791]	
53.0	13	41	70	98	127	155	183	211	239	253	315	
	360	358	356	355	353	350	346	340	334	330	307	
[15]	[88]	[343]	[599]	[848]	[1106]	[1353]	[1605]	[1852]	[2099]	[2224]	[2771]	
Max. Continuous	10	39	68	96	125	153	181	209	237	251	313	
	385	384	382	380	378	375	371	365	359	355	332	
Max. Inter-mittent	[20]		[218]	[499]	[752]	[1037]	[1277]	[1523]	[1765]	[2004]	[2121]	
			25	56	85	117	144	172	199	226	240	
			510	507	504	501	498	492	485	480		

159 cm<sup>3</sup>/r [9.7 in<sup>3</sup>/r]  
Δ Pressure Bar [PSI]  
Continuous

	[200]	[400]	[600]	[800]	[1000]	[1200]	[1400]	[1600]	[1800]	[1900]	Max. Continuous	Max. Inter-mittent
	14	28	41	55	69	83	97	110	124	131	[2350]	159
[2]	[253]	[536]	[805]	[1090]	[1364]	[1623]	[1884]	[2129]	[2365]	[2477]		
7.6	29	61	91	123	154	183	213	241	267	280		
	47	46	45	44	42	39	35	31	26	23		
[4]	[254]	[537]	[816]	[1091]	[1365]	[1641]	[1910]	[2180]	[2440]	[2567]	[3042]	
15.1	29	61	92	123	154	185	216	246	276	291	343	
	94	93	92	91	89	87	84	81	77	76	65	
[6]	[238]	[517]	[797]	[1079]	[1356]	[1632]	[1906]	[2177]	[2434]	[2565]	[3059]	
22.7	27	58	90	121	153	184	215	245	275	289	345	
	141	140	139	138	136	134	130	126	119	116	100	
[8]	[217]	[502]	[784]	[1057]	[1328]	[1608]	[1884]	[2155]	[2421]	[2554]	[3072]	
30.3	24	56	88	119	150	181	212	242	272	288	347	
	188	187	186	185	183	181	178	174	168	164	147	
[10]	[198]	[484]	[754]	[1025]	[1307]	[1587]	[1868]	[2126]	[2406]	[2537]	[3055]	
37.9	22	54	85	115	147	179	211	240	271	286	345	
	236	235	233	232	230	227	224	221	215	212	194	
[12]	[177]	[446]	[707]	[998]	[1289]	[1556]	[1837]	[2103]	[2369]	[2505]	[3044]	
45.4	20	50	79	112	145	175	207	237	267	283	344	
	283	281	280	278	277	274	271	268	262	259	242	
[14]	[137]	[415]	[685]	[966]	[1242]	[1514]	[1794]	[2069]	[2341]	[2475]	[3005]	
53.0	15	46	77	109	140	171	202	233	264	279	339	
	330	328	326	326	324	322	318	314	309	305	289	
[15]	[110]	[395]	[667]	[947]	[1225]	[1493]	[1776]	[2052]	[2317]	[2455]	[2983]	
Max. Continuous	12	44	75	107	138	168	200	231	261	277	337	
	353	352	350	349	348	345	341	337	333	329	313	
Max. Inter-mittent	[20]		[284]	[565]	[844]	[1123]	[1394]	[1675]	[1942]	[2211]	[2342]	
			32	63	95	126	157	189	219	249	264	
			469	468	466	463	462	459	455	450	446	

185 cm<sup>3</sup>/r [11.3 in<sup>3</sup>/r]  
Δ Pressure Bar [PSI]  
Continuous

	[200]	[400]	[600]	[800]	[1000]	[1200]	[1400]	[1600]	[1800]	[1850]	Max. Continuous	Max. Inter-mittent
	14	28	41	55	69	83	97	110	124	128	[2250]	155
[2]	[296]	[623]	[942]	[1263]	[1577]	[1874]	[2172]	[2450]	[2499]	[2500]		
7.6	33	70	106	143	178	212	245	277	282	282		
	40	40	39	38	36	34	31	27	21	20		
[4]	[294]	[619]	[947]	[1265]	[1588]	[1896]	[2200]	[2503]	[2796]	[2868]	[3439]	
15.1	33	70	107	143	179	214	249	283	316	324	389	
	81	80	80	79	77	76	73	71	68	67	63	
[6]	[277]	[602]	[928]	[1255]	[1574]	[1889]	[2196]	[2505]	[2796]	[2870]	[3448]	
22.7	31	68	105	142	178	213	248	283	316	324	390	
	121	121	120	119	117	115	112	108	103	101	87	
[8]	[255]	[582]	[908]	[1229]	[1546]	[1864]	[2180]	[2487]	[2786]	[2861]	[3450]	
30.3	29	66	103	139	175	211	246	281	315	323	390	
	162	161	161	160	158	156	153	150	144	142	130	
[10]	[231]	[560]	[879]	[1195]	[1521]	[1838]	[2160]	[2460]	[2766]	[2841]	[3433]	
37.9	26	63	99	135	172	208	244	278	313	321	388	
	202	202	201	200	198	196	193	190	184	183	170	
[12]	[199]	[522]	[832]	[1163]	[1491]	[1803]	[2127]	[2434]	[2734]	[2810]	[3414]	
45.4	22	59	94	131	168	204	240	275	309	317	386	
	243	242	241	240	239	237	234	231	225	224	212	
[14]	[157]	[485]	[802]	[1124]	[1444]	[1763]	[2080]	[2392]	[2698]	[2774]	[3378]	
53.0	18	55	91	127	163	199	235	270	305	313	382	
	283	283	281	281	279	277	274	271	266	264	250	
[15]	[132]	[461]	[780]	[1103]	[1422]	[1739]	[2059]	[2372]	[2674]	[2751]	[3374]	
Max. Continuous	15	52	88	125	162	196	233	268	302	311	381	
	303	303	302	301	299	298	295	291	286	285	271	
Max. Inter-mittent	[20]		[335]	[662]	[987]	[1307]	[1623]	[1930]	[2227]	[2524]	[2597]	
			38	75	112	148	183	218	252	285	293	
			404	403	401	399	397	395	392	387	385	

231 cm<sup>3</sup>/r [14.1 in<sup>3</sup>/r]  
Δ Pressure Bar [PSI]  
Continuous

	[200]	[400]	[600]	[800]	[1000]	[1200]	[1400]	[1600]	[1700]	[1850]	Max. Continuous	Max. Inter-mittent
	14	28	41	55	69	83	97	110	117		[2050]	141
[2]	[372]	[776]	[1182]	[1567]	[1952]	[2317]	[2682]	[3039]	[2925]			
7.6	42	88	134	177	221	262	303	341	330			
	32	32	31	30	28	28	22	21	19			
[4]	[364]	[764]	[1178]	[1572]	[1979]	[2346]	[2714]	[3078]	[3255]	[3871]		
15.1	41	86	133	178	224	265	307	348	368	437		
	65	65	64	63	62	62	60	58	57	54		
[6]	[345]	[750]	[1156]	[1564]	[1958]	[2342]	[2710]	[3087]	[3265]	[3875]		
22.7	39	85	131	177	221	265	306	349	369	438		
	97	97	97	96	95	93	91	87	85	74		
[8]	[320]	[723]	[1128]	[1530]	[1928]	[2315]	[2702]	[3073]	[3254]	[3877]		
30.3	36	82	127	173	218	262	305	347	368	438		
	130	130	129	129	128							

# Performance Data S Series

Motors run with high efficiency in all areas designated with a number for torque and speed, however for best motor life select a motor to run with a torque and speed range shown in the light blue area.

		293 cm <sup>3</sup> /r [17.9 in <sup>3</sup> /r] Δ Pressure Bar [PSI] Continuous										Max. Contin- uous	Max. Inter- mittent
		[200]	[400]	[600]	[800]	[1000]	[1200]	[1400]	[1500]	[1800]			
		14	28	41	55	69	83	97	103	124			
Flow LPM [GPM]	[2]	[471]	[990]	[1502]	[1995]	[2393]	[2837]	[3270]					
		53	112	170	225	270	321	369					
	7,6	26	25	25	24	20	17	12					
	[4]	[465]	[988]	[1502]	[2001]	[2499]	[2967]	[3413]	[3638]	[4295]			
		53	112	170	226	282	335	386	411	485			
	15,1	51	51	50	50	49	49	47	46	42			
	[6]	[443]	[959]	[1474]	[1985]	[2477]	[2955]	[3415]	[3641]	[4293]			
		50	108	167	224	280	334	386	411	485			
	22,7	77	77	76	76	75	73	69	67	59			
	[8]	[411]	[927]	[1433]	[1946]	[2439]	[2916]	[3402]	[3624]	[4269]			
	46	105	162	220	276	329	384	409	482				
30,3	102	102	102	102	101	100	95	93	84				
[10]	[372]	[882]	[1393]	[1890]	[2399]	[2872]	[3354]	[3583]	[4251]				
	42	100	157	214	271	324	379	405	480				
37,9	128	128	128	127	126	125	122	119	112				
[12]	[318]	[837]	[1340]	[1844]	[2340]	[2820]	[3308]	[3543]	[4235]				
	36	95	151	208	264	319	374	400	478				
45,4	153	153	153	153	152	150	147	145	137				
[14]	[253]	[773]	[1281]	[1784]	[2275]	[2770]	[3251]	[3482]	[4166]				
	29	87	145	202	257	313	367	393	471				
53,0	179	179	179	178	178	176	173	171	164				
Max. Continuous	[15]	[225]	[738]	[1244]	[1748]	[2240]	[2731]	[3218]	[3450]	[4136]			
	25	83	141	197	253	309	364	390	467				
56,8	192	192	191	191	190	189	185	183	177				
Max. Intermittent	[20]		[558]	[1077]	[1577]	[2065]	[2546]	[3010]	[3230]				
			63	122	178	233	288	340	365				
75,7			256	255	255	254	253	250	247				

		370 cm <sup>3</sup> /r [22.6 in <sup>3</sup> /r] Δ Pressure Bar [PSI] Continuous										Max. Contin- uous	Max. Inter- mittent
		[200]	[400]	[600]	[800]	[1000]	[1200]	[1300]	[1500]				
		14	28	41	55	69	83	90	103				
Flow LPM [GPM]	[2]	[593]	[1256]	[1898]	[2525]	[3082]	[3655]	[3935]					
		67	142	214	285	348	413	445					
	7,6	21	20	20	19	14	10	7					
	[4]	[590]	[1270]	[1905]	[2534]	[3139]	[3734]	[4004]	[4544]				
		67	143	215	286	355	422	452	513				
	15,1	41	41	40	40	39	39	38	37				
	[6]	[566]	[1218]	[1869]	[2506]	[3117]	[3708]	[3996]	[4548]				
		64	138	211	283	352	419	451	514				
	22,7	62	61	61	60	60	57	55	50				
	[8]	[524]	[1181]	[1810]	[2461]	[3069]	[3652]	[3956]	[4523]				
	59	133	205	278	347	413	447	511					
30,3	82	82	81	81	80	79	77	71					
[10]	[477]	[1117]	[1757]	[2381]	[3019]	[3596]	[3889]	[4459]					
	54	126	199	269	341	406	439	504					
37,9	102	102	101	101	100	99	97	93					
[12]	[419]	[1067]	[1705]	[2326]	[2945]	[3533]	[3830]	[4416]					
	47	121	193	263	333	399	433	499					
45,4	123	122	122	122	120	119	118	113					
[14]	[328]	[976]	[1625]	[2259]	[2862]	[3470]	[3768]	[4348]					
	37	110	184	255	323	392	426	491					
53,0	143	143	143	142	141	140	138	133					
Max. Continuous	[15]	[297]	[939]	[1576]	[2210]	[2824]	[3418]	[3721]	[4309]				
	34	106	178	250	319	386	420	487					
56,8	153	153	153	152	151	150	148	144					
Max. Intermittent	[20]		[729]	[1387]	[2001]	[2604]	[3186]	[3482]					
			82	157	226	294	360	393					
75,7			203	203	202	202	201	199					

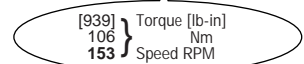

Performance data is typical at 120 SUS. Actual data may vary slightly from unit to unit in production

# Dimensions S Series

## 2 Bolt Flange

82,55/82,42  
[3.250/3.245]  
Pilot Dia.

Standard Rotation  
Viewed from Shaft End  
Port A Pressurized — CW  
Port B Pressurized — CCW

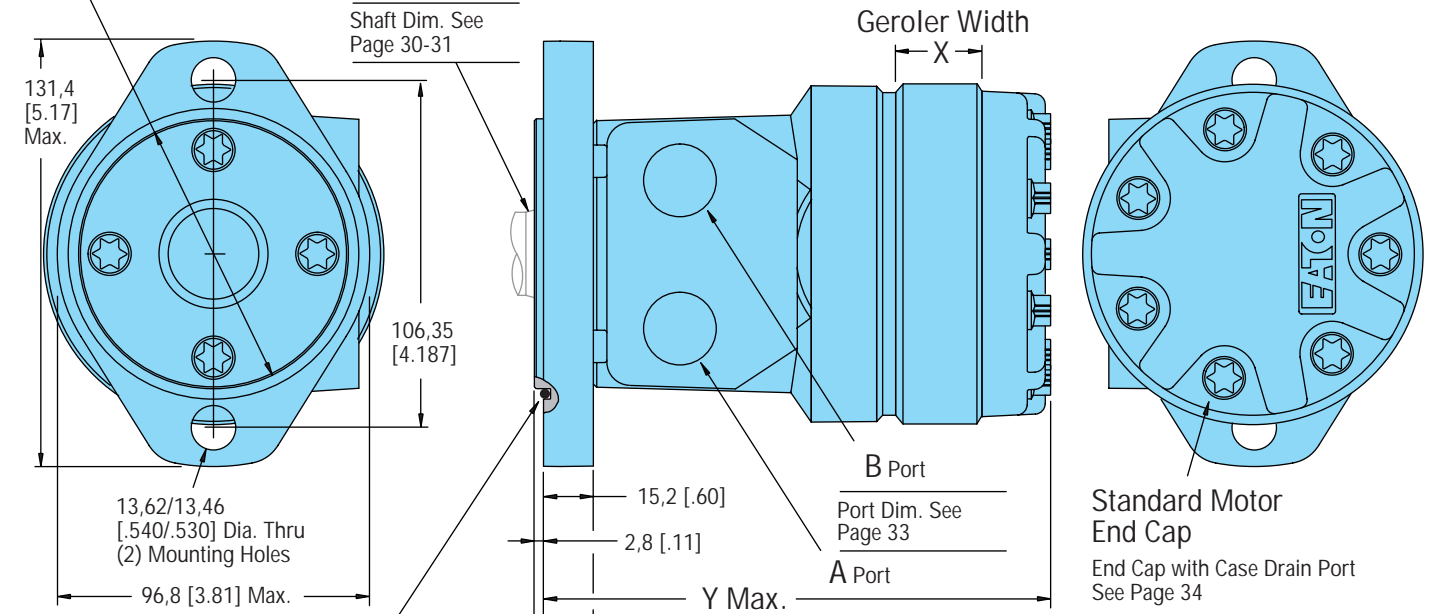

## 4 Bolt Flange

41,4 [1.63] (2)

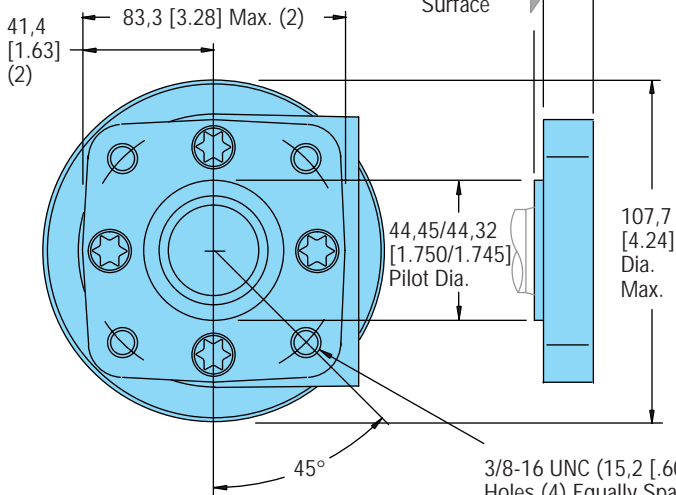

3/8-16 UNC (15,2 [.60] Max. Bolt Thread Engagement ) Mounting Holes (4) Equally Spaced on 82,6 [3.25] Dia. Bolt Circle  
or  
M10 x 1,5 (15,2 [.60] Max. Bolt Thread Engagement ) Mounting Holes (4) Equally Spaced on 82,6 [3.25] Dia. Bolt Circle

Displ. cm <sup>3</sup> /r [in <sup>3</sup> /r]	X	Y Max.
	Width mm [in.]	Length mm [in.]
59 [ 3.6]	10,2 [ .40]	139,2 [5.48]
74 [ 4.5]	10,2 [ .40]	139,2 [5.48]
97 [ 5.9]	13,2 [ .52]	142,3 [5.60]
120 [ 7.3]	16,5 [ .65]	145,6 [5.73]
146 [ 8.9]	20,1 [ .79]	149,1 [5.87]
159 [ 9.7]	21,9 [ .86]	150,9 [5.94]
185 [11.3]	25,4 [1.00]	154,5 [6.08]
231 [14.1]	31,8 [1.25]	160,8 [6.33]
293 [17.9]	40,4 [1.59]	169,5 [6.67]
370 [22.6]	50,8 [2.00]	179,9 [7.08]

Note: Mounting Surface Flatness Requirement is  $\nabla$  ,13 mm [.005 inch] Max.

# Product Numbers S Series 103-xxxx

## Product Numbers—S Series

Add three digit prefix —103—to four digit number from chart for complete product number—Example 103-1537.  
Orders will not be accepted without three digit prefix.

Mounting	Shaft	Ports	Displ. cm <sup>3</sup> /r [in <sup>3</sup> /r] Product Number 103-xxxx									
			59 [ 3.6]	74 [ 4.5]	97 [ 5.9]	120 [ 7.3]	146 [ 8.9]	159 [ 9.7]	185 [11.3]	231 [14.1]	293 [17.9]	370 [22.6]
2 Bolt Flange	1 in. Straight w/Woodruff Key	7/8-14 O-ring	103-1537	-1034	-1035	-1538	-1539	-1036	-1037	-1038	-1039	-1040
		1/2 NPTF	103-1540	-1026	-1027	-1541	-1542	-1028	-1029	-1030	-1031	-1032
		Manifold*	103-1543	-1042	-1043	-1544	-1545	-1044	-1045	-1046	-1047	-1048
	1 in. SAE 6B Splined	7/8-14 O-ring	103-1552	-1082	-1083	-1553	-1554	-1084	-1085	-1086	-1087	-1088
		1/2 NPTF	103-1555	-1074	-1075	-1556	-1557	-1076	-1077	-1078	-1079	-1080
		Manifold*	103-1558	-1090	-1091	-1559	-1560	-1092	-1093	-1094	-1095	-1096
4 Bolt Flange	1 in. Straight w/Woodruff Key	7/8-14 O-ring	103-1570	-1010	-1011	-1571	-1572	-1012	-1013	-1014	-1015	-1016
		1/2 NPTF	103-1573	-1002	-1003	-1574	-1575	-1004	-1005	-1006	-1007	-1008
		Manifold*	103-1576	-1018	-1019	-1577	-1578	-1020	-1021	-1022	-1023	-1024
	1 in. SAE 6B Splined	7/8-14 O-ring	103-1579	-1058	-1059	-1580	-1581	-1060	-1061	-1062	-1063	-1064
		1/2 NPTF	103-1582	-1050	-1051	-1583	-1584	-1052	-1053	-1054	-1055	-1056
		Manifold*	103-1585	-1066	-1067	-1586	-1587	-1068	-1069	-1070	-1071	-1072

\*Manifold product numbers shown are for motors with four 5/16-18 port face mounting threads. Manifold, manifold mounting o-rings and bolts are NOT included (for M8 x 1.5 port face mounting threads see note below).

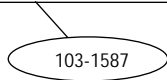

## Product Numbers—S Series Motors with Corrosion Protection

Shaft	Mounting	Ports	Displ. cu. cm/rev. [cu. in./rev.] Product Number 103-xxxx									
			59 [ 3.6]	74 [ 4.5]	97 [ 5.9]	120 [ 7.3]	146 [ 8.9]	159 [ 9.7]	185 [11.3]	231 [14.1]	293 [17.9]	370 [22.6]
1 in. Straight w/Woodruff Key	2 Bolt Flange	7/8-14 O-ring	103-1645							-1649	-1650	
	4 Bolt Flange	1/2 NPTF								-1620	-1621	

For S Series Motors with a configuration Not Shown in the charts above: Use the model code number system on page 38 to specify the product in detail.

For Product Numbers—S Series Motors with Low Speed Valving — See Page 28.

# Specifications T Series

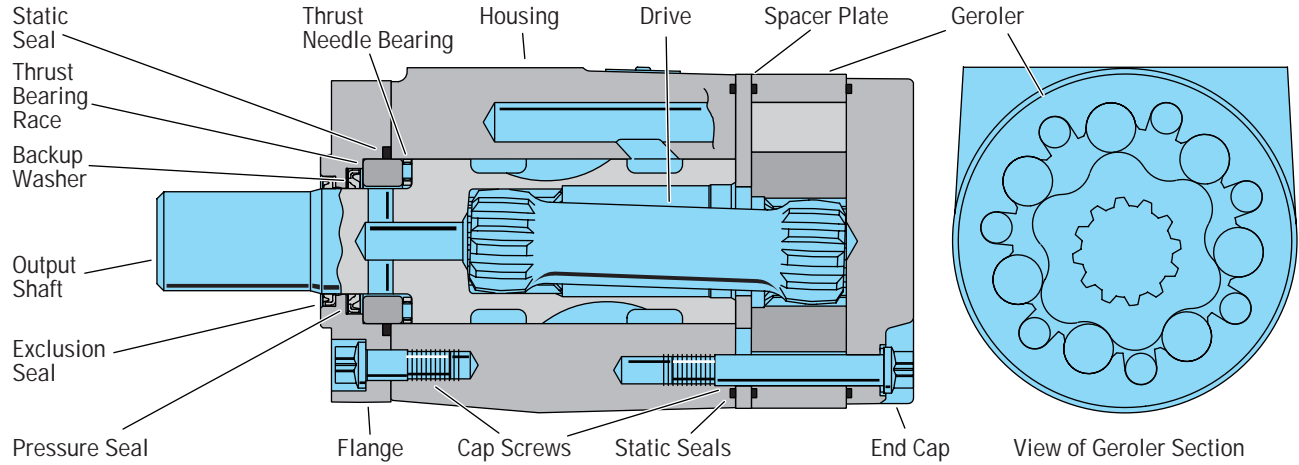

## Specification Data —T Series

Displ. cm <sup>3</sup> /r [in <sup>3</sup> /r]		36 [2.2]	49 [3.0]	66 [4.0]	80 [4.9]	102 [6.2]	131 [8.0]	157 [9.6]	195 [11.9]	244 [14.9]	306 [18.7]	370 [22.6]
Max. Speed (RPM) @ Continuous Flow		1021	906	849	694	550	426	355	287	229	183	152
Flow LPM [GPM]	Continuous	38 [10]	45 [12]	57 [15]	57 [15]	57 [15]	57 [15]	57 [15]	57 [15]	57 [15]	57 [15]	57 [15]
	Intermittent	38 [10]	57 [15]	68 [18]	76 [20]	76 [20]	76 [20]	76 [20]	76 [20]	76 [20]	76 [20]	76 [20]
Torque Nm [lb-in]	Continuous	76 [672]	105 [928]	138 [1222]	174 [1541]	219 [1936]	251 [2226]	297 [2628]	359 [3178]	410 [3633]	441 [3905]	430 [3811]
	Intermittent **	93 [824]	118 [1131]	168 [1488]	212 [1872]	264 [2339]	307 [2718]	359 [3178]	437 [3864]	485 [4290]	483 [4275]	486 [4300]
Pressure Δ Bar [Δ PSI]	Continuous*	155 [2250]	155 [2250]	155 [2250]	155 [2250]	155 [2250]	138 [2000]	138 [2000]	138 [2000]	127 [1850]	110 [1600]	90 [1300]
	Intermittent**	190 [2750]	190 [2750]	190 [2750]	190 [2750]	190 [2750]	172 [2500]	172 [2500]	172 [2500]	155 [2250]	124 [1800]	103 [1500]

Maximum Case Pressure w/o Case Drain — 103 Bar [1500 PSI] see pages 34-35.

- \* Maximum intermittent pressure at motor inlet port of 190 Bar [2750 PSI] without regard to Δ Bar [Δ PSI] and/or back pressure ratings or combination thereof.
- \*\* A simultaneous maximum torque and maximum speed NOT recommended.  
6B Splined or Tapered shafts are recommended whenever operating above 282 Nm [2500 lb-in] of torque, especially for those applications subject to frequent reversals (see page 30).  
Δ Bar [Δ PSI]— True pressure difference between inlet port and outlet port.  
Continuous Rating — Motor may be run continuously at these ratings.  
Intermittent Operation — 10% of every minute.  
Recommended Fluids — Premium quality, anti-wear type hydraulic oil with a viscosity of not less than 70 SUS at operating temperature (see page 36).  
Recommended Maximum System Operating Temp. — Is 82° C [180° F]  
Recommended Filtration — per ISO Cleanliness Code, level 18/13

To assure best motor life, run motor for approximately one hour at 30% of rated pressure before application to full load. Be sure motor is filled with fluid prior to any load applications.

# Performance Data T Series

Motors run with high efficiency in all areas designated with a number for torque and speed, however for best motor life select a motor to run with a torque and speed range shown in the light blue area.

36 cm<sup>3</sup>/r [2.2 in<sup>3</sup>/r]  
Δ Pressure Bar [PSI]  
Continuous

		[200]	[400]	[600]	[800]	[1000]	[1200]	[1400]	[1600]	[1800]	[2000]	[2200]	[2250]	[2750]
		14	28	41	55	69	83	97	110	124	138	152	155	190
Flow LPM [GPM]	[2]	[50] 6	[110] 12	[172] 19	[233] 26	[291] 33	[348] 39	[401] 45	[455] 51	[501] 57	[546] 62	[590] 67	[596] 67	[635] 72
	7,6	209	203	197	191	189	181	167	164	153	139	122	116	64
	[4]	[50] 6	[109] 12	[172] 19	[233] 26	[296] 33	[355] 40	[414] 47	[475] 54	[534] 60	[584] 66	[646] 73	[659] 74	[786] 89
	15,1	415	411	398	388	384	381	368	357	354	323	304	302	283
	[6]	[43] 5	[108] 12	[171] 19	[233] 26	[298] 34	[361] 41	[420] 47	[479] 54	[538] 61	[595] 67	[657] 74	[672] 76	[824] 93
22,7	617	613	602	595	585	570	563	558	534	520	504	496	425	
[8]	[39] 4	[101] 11	[164] 19	[226] 26	[292] 33	[354] 40	[415] 47	[475] 54	[538] 61	[592] 67	[656] 74	[670] 76	[819] 92	
30,3	821	815	803	797	784	774	758	747	732	707	688	680	607	
Max. Continuous	[10]	[30] 3	[93] 11	[155] 18	[214] 24	[278] 31	[342] 39	[406] 46	[473] 53	[532] 60	[590] 67	[650] 73	[668] 75	[805] 91
37,9	1021	1014	1002	999	981	965	953	937	921	903	880	873	799	

[93] Torque [lb-in]  
11 Nm  
1014 Speed RPM

49 cm<sup>3</sup>/r [3.0 in<sup>3</sup>/r]  
Δ Pressure Bar [PSI]  
Continuous

		[200]	[400]	[600]	[800]	[1000]	[1200]	[1400]	[1600]	[1800]	[2000]	[2200]	[2250]	[2750]
		14	28	41	55	69	83	97	110	124	138	152	155	190
Flow LPM [GPM]	[2]	[73] 8	[161] 18	[245] 28	[327] 37	[408] 46	[486] 55	[563] 64	[641] 72	[710] 80	[786] 89	[849] 96	[866] 98	[1023] 116
	7,6	152	152	148	147	142	141	134	124	115	109	95	92	58
	[4]	[72] 8	[160] 18	[246] 28	[329] 37	[416] 47	[500] 56	[584] 66	[668] 75	[746] 84	[825] 93	[901] 102	[922] 104	[1123] 127
	15,1	303	298	294	290	276	273	265	261	245	243	235	228	152
	[6]	[58] 7	[148] 17	[234] 26	[326] 37	[413] 47	[500] 56	[583] 66	[663] 75	[746] 84	[827] 93	[909] 103	[928] 105	[1131] 128
22,7	461	450	445	438	434	421	419	410	407	389	376	373	344	
[8]	[44] 5	[127] 14	[216] 24	[306] 35	[392] 44	[480] 54	[566] 64	[652] 74	[734] 83	[815] 92	[897] 101	[917] 104	[1125] 127	
30,3	607	603	600	590	583	576	564	554	545	536	522	520	503	
Max. Continuous	[10]	[39] 4	[128] 14	[213] 24	[302] 34	[391] 44	[477] 54	[562] 63	[647] 73	[731] 83	[815] 92	[897] 101	[917] 104	[1121] 127
37,9	755	750	745	738	732	719	713	702	696	682	663	661	638	
Max. Inter-mittent	[12]	[33] 4	[119] 13	[203] 23	[291] 33	[378] 43	[464] 52	[551] 62	[635] 72	[719] 81	[802] 91	[883] 100	[900] 96	[1061] 120
45,4	906	902	895	883	875	862	859	844	835	819	806	804	788	
Max. Inter-mittent	[15]	[26] 3	[86] 10	[172] 19	[256] 29	[342] 39	[430] 49	[505] 57	[591] 67	[674] 76	[745] 84	[830] 94	[851] 96	56,8

Performance data is typical at 120 SUS. Actual data may vary slightly from unit to unit in production

# Performance Data T Series

Motors run with high efficiency in all areas designated with a number for torque and speed, however for best motor life select a motor to run with a torque and speed range shown in the light blue area.

66 cm<sup>3</sup>/r [4.0 in<sup>3</sup>/r]  
Δ Pressure Bar [PSI]  
Continuous

		[200]	[400]	[600]	[800]	[1000]	[1200]	[1400]	[1600]	[1800]	[2000]	[2200]	[2250]	[2750]	
		14	28	41	55	69	83	97	110	124	138	152	155	190	
Flow LPM [GPM]	[2] 7,6	[78] 9 114	[191] 22 111	[303] 34 110	[414] 47 107	[522] 59 105	[625] 71 101	[706] 80 96	[804] 91 101	[898] 101 87	[991] 112 81	[1081] 122 73	[1103] 125 72	[1318] 149 48	
	[4] 15,1	[97] 11 229	[209] 24 229	[325] 37 217	[441] 50 216	[548] 62 212	[657] 74 205	[766] 87 194	[873] 99 190	[972] 110 186	[1077] 122 183	[1181] 133 181	[1205] 136 178	[1437] 162 170	
	[6] 22,7	[79] 9 344	[192] 22 343	[309] 35 335	[426] 48 334	[534] 60 321	[649] 73 320	[760] 86 319	[874] 99 315	[984] 111 291	[1090] 123 288	[1190] 134 279	[1218] 138 276	[1488] 168 270	
	[8] 30,3	[75] 8 456	[191] 22 451	[304] 34 447	[419] 47 442	[532] 60 431	[645] 73 426	[759] 86 419	[871] 98 415	[982] 111 412	[1092] 123 401	[1197] 135 391	[1222] 138 386	[1458] 165 339	
	[10] 37,9	[49] 6 569	[163] 18 565	[283] 32 560	[398] 45 552	[509] 58 547	[623] 70 541	[742] 84 532	[856] 97 525	[971] 110 512	[1080] 122 504	[1186] 134 498	[1209] 137 496	[1425] 161 475	
	[12] 45,4	[24] 3 681	[156] 18 678	[270] 31 671	[385] 43 665	[502] 57 658	[614] 69 651	[729] 82 641	[845] 95 635	[963] 109 623	[1067] 121 612	[1182] 134 604	[1209] 137 601	[1472] 166 571	
	[14] 53,0	[19] 2 793	[143] 16 788	[261] 29 787	[370] 42 778	[485] 55 771	[602] 68 762	[718] 81 753	[837] 95 746	[948] 107 733	[1064] 120 723	[1175] 133 715	[1199] 135 711	[1436] 162 677	
	Max. Continuous	[15] 1 56,8	[13] 14 849	[120] 27 844	[236] 40 839	[352] 53 832	[471] 67 826	[590] 80 819	[707] 93 806	[823] 106 800	[939] 119 786	[1052] 132 779	[1165] 137 770	[1192] 135 766	[1462] 165 725
	Max. Intermittent	[18] 68,1	[107] 12 1006	[215] 24 1003	[326] 37 998	[442] 50 988	[555] 63 976	[669] 76 975	[786] 89 965	[900] 102 952	[1016] 115 940	[1123] 127 924	[1152] 130 919		

80 cm<sup>3</sup>/r [4.9 in<sup>3</sup>/r]  
Δ Pressure Bar [PSI]  
Continuous

		[200]	[400]	[600]	[800]	[1000]	[1200]	[1400]	[1600]	[1800]	[2000]	[2200]	[2250]	[2750]	
		14	28	41	55	69	83	97	110	124	138	152	155	190	
Flow LPM [GPM]	[2] 7,6	[123] 14 93	[265] 30 90	[405] 46 86	[544] 61 83	[680] 77 80	[804] 91 75	[934] 106 70	[1052] 119 63	[1181] 133 57	[1079] 122 43	[937] 106 24	[895] 101 20		
	[4] 15,1	[120] 14 187	[264] 30 185	[406] 46 183	[551] 62 179	[689] 78 175	[828] 94 171	[965] 109 166	[1101] 124 162	[1237] 140 156	[1369] 155 150	[1505] 170 142	[1537] 174 140	[1857] 210 121	
	[6] 22,7	[113] 13 279	[255] 29 275	[398] 45 271	[542] 61 267	[682] 77 265	[823] 93 258	[963] 109 253	[1101] 124 248	[1239] 140 240	[1373] 155 232	[1508] 170 223	[1541] 174 221	[1868] 211 198	
	[8] 30,3	[99] 11 372	[243] 27 367	[386] 44 364	[528] 60 359	[669] 76 354	[812] 92 351	[954] 108 343	[1094] 124 338	[1233] 139 333	[1368] 155 324	[1503] 170 315	[1537] 174 313	[1872] 212 289	
	[10] 37,9	[84] 9 463	[228] 26 460	[371] 42 456	[514] 58 450	[655] 74 446	[798] 90 441	[941] 106 435	[1080] 122 428	[1219] 138 420	[1357] 153 412	[1496] 169 403	[1530] 173 399	[1870] 211 368	
	[12] 45,4	[63] 7 557	[209] 24 552	[354] 40 547	[498] 56 543	[638] 72 537	[782] 88 530	[926] 105 523	[1067] 121 515	[1208] 136 509	[1346] 152 500	[1484] 168 489	[1520] 177 472	[1864] 210 470	
	[14] 53,0	[55] 6 649	[185] 21 646	[331] 37 642	[476] 54 635	[620] 70 630	[762] 86 622	[904] 102 616	[1046] 118 609	[1188] 134 599	[1327] 150 592	[1467] 166 581	[1502] 170 578	[1842] 208 550	
	Max. Continuous	[15] 6 56,8	[51] 20 694	[176] 36 691	[316] 43 687	[463] 52 680	[609] 69 673	[748] 85 668	[891] 101 660	[1037] 117 650	[1177] 133 642	[1316] 149 634	[1457] 165 622	[1491] 168 619	[1844] 208 598
	Max. Intermittent	[20] 75,7	[160] 18 916	[305] 34 910	[455] 51 893	[578] 65 893	[737] 83 875	[857] 97 866	[968] 109 877	[1144] 129 843	[1277] 144 833	[1412] 160 839	[1446] 163 836		

[176]  
20  
691 } Torque [lb-in]  
Nm  
Speed RPM

Performance data is typical at 120 SUS. Actual data may vary slightly from unit to unit in production

# Performance Data T Series

Motors run with high efficiency in all areas designated with a number for torque and speed, however for best motor life select a motor to run with a torque and speed range shown in the light blue area.

102 cm<sup>3</sup>/r [6.2 in<sup>3</sup>/r]  
Δ Pressure Bar [PSI]  
Continuous

	[200]	[400]	[600]	[800]	[1000]	[1200]	[1400]	[1600]	[1800]	[2000]	[2200]	[2250]	[2750]
	14	28	41	55	69	83	97	110	124	138	152	155	190
[2]	[161]	[341]	[519]	[697]	[871]	[1030]	[1193]	[1349]	[1511]	[1496]	[1441]	[1421]	
	18	39	59	79	98	116	135	152	171	169	163	161	
<b>7,6</b>	<b>73</b>	<b>71</b>	<b>68</b>	<b>66</b>	<b>63</b>	<b>60</b>	<b>56</b>	<b>51</b>	<b>46</b>	<b>36</b>	<b>23</b>	<b>20</b>	
[4]	[157]	[340]	[520]	[702]	[879]	[1056]	[1229]	[1401]	[1567]	[1727]	[1889]	[1925]	[2271]
	18	38	59	79	99	119	139	158	177	195	213	217	257
<b>15,1</b>	<b>149</b>	<b>146</b>	<b>144</b>	<b>141</b>	<b>138</b>	<b>135</b>	<b>131</b>	<b>128</b>	<b>124</b>	<b>118</b>	<b>111</b>	<b>109</b>	<b>92</b>
[6]	[147]	[329]	[510]	[692]	[871]	[1050]	[1227]	[1401]	[1571]	[1731]	[1895]	[1936]	[2339]
	17	37	58	78	98	119	139	158	178	196	214	219	264
<b>22,7</b>	<b>221</b>	<b>217</b>	<b>214</b>	<b>211</b>	<b>208</b>	<b>204</b>	<b>199</b>	<b>195</b>	<b>190</b>	<b>184</b>	<b>176</b>	<b>174</b>	<b>154</b>
[8]	[132]	[315]	[497]	[675]	[857]	[1038]	[1216]	[1392]	[1564]	[1725]	[1891]	[1932]	[2326]
	15	36	56	76	97	117	137	157	177	195	214	218	263
<b>30,3</b>	<b>294</b>	<b>290</b>	<b>287</b>	<b>284</b>	<b>280</b>	<b>277</b>	<b>271</b>	<b>267</b>	<b>262</b>	<b>255</b>	<b>247</b>	<b>245</b>	<b>220</b>
[10]	[109]	[293]	[477]	[657]	[839]	[1018]	[1198]	[1374]	[1542]	[1711]	[1878]	[1918]	[2326]
	12	33	54	74	95	115	135	155	174	193	212	217	263
<b>37,9</b>	<b>367</b>	<b>363</b>	<b>360</b>	<b>355</b>	<b>351</b>	<b>347</b>	<b>343</b>	<b>337</b>	<b>332</b>	<b>325</b>	<b>318</b>	<b>315</b>	<b>287</b>
[12]	[84]	[271]	[457]	[638]	[818]	[999]	[1179]	[1354]	[1527]	[1697]	[1858]	[1901]	[2323]
	9	31	52	72	92	113	133	153	173	192	210	215	262
<b>45,4</b>	<b>440</b>	<b>436</b>	<b>432</b>	<b>429</b>	<b>424</b>	<b>419</b>	<b>414</b>	<b>409</b>	<b>402</b>	<b>395</b>	<b>386</b>	<b>384</b>	<b>364</b>
[14]	[59]	[242]	[428]	[611]	[794]	[974]	[1151]	[1328]	[1502]	[1674]	[1841]	[1883]	[2301]
	7	27	48	69	90	110	130	150	170	189	208	213	260
<b>53,0</b>	<b>513</b>	<b>510</b>	<b>506</b>	<b>501</b>	<b>497</b>	<b>492</b>	<b>487</b>	<b>482</b>	<b>475</b>	<b>469</b>	<b>458</b>	<b>456</b>	<b>428</b>
Max. Continuous	[39]	[227]	[411]	[595]	[780]	[957]	[1136]	[1314]	[1486]	[1658]	[1828]	[1869]	[2285]
	4	26	46	67	88	108	128	148	168	187	207	211	258
<b>56,8</b>	<b>550</b>	<b>545</b>	<b>542</b>	<b>537</b>	<b>532</b>	<b>528</b>	<b>522</b>	<b>516</b>	<b>510</b>	<b>502</b>	<b>492</b>	<b>490</b>	<b>463</b>
Max. Inter-mittent	[20]	[154]	[328]	[515]	[710]	[874]	[1060]	[1243]	[1405]	[1579]	[1763]	[1803]	
		17	37	58	80	99	120	140	159	178	199	204	
<b>75,7</b>		<b>724</b>	<b>718</b>	<b>720</b>	<b>709</b>	<b>707</b>	<b>696</b>	<b>684</b>	<b>683</b>	<b>670</b>	<b>659</b>	<b>660</b>	

131 cm<sup>3</sup>/r [8.0 in<sup>3</sup>/r]  
Δ Pressure Bar [PSI]  
Continuous

	[200]	[400]	[600]	[800]	[1000]	[1200]	[1400]	[1600]	[1800]	[2000]	[2500]
	14	28	41	55	69	83	97	110	124	138	172
[2]	[219]	[450]	[682]	[915]	[1144]	[1348]	[1561]	[1771]	[1979]	[2159]	
	25	51	77	103	129	152	176	200	224	244	
<b>7,6</b>	<b>57</b>	<b>55</b>	<b>53</b>	<b>51</b>	<b>49</b>	<b>47</b>	<b>43</b>	<b>40</b>	<b>36</b>	<b>30</b>	
[4]	[212]	[449]	[681]	[917]	[1148]	[1376]	[1600]	[1822]	[2025]	[2221]	[2629]
	24	51	77	104	130	155	181	206	229	251	297
<b>15,1</b>	<b>115</b>	<b>113</b>	<b>110</b>	<b>109</b>	<b>107</b>	<b>105</b>	<b>102</b>	<b>99</b>	<b>96</b>	<b>91</b>	<b>75</b>
[6]	[197]	[435]	[669]	[903]	[1139]	[1370]	[1600]	[1818]	[2032]	[2226]	[2718]
	22	49	76	102	129	155	181	205	230	252	307
<b>22,7</b>	<b>171</b>	<b>168</b>	<b>166</b>	<b>163</b>	<b>160</b>	<b>157</b>	<b>154</b>	<b>150</b>	<b>147</b>	<b>142</b>	<b>125</b>
[8]	[181]	[417]	[657]	[886]	[1122]	[1359]	[1589]	[1812]	[2022]	[2215]	[2699]
	20	47	74	100	127	154	180	205	228	250	305
<b>30,3</b>	<b>227</b>	<b>225</b>	<b>222</b>	<b>219</b>	<b>217</b>	<b>213</b>	<b>209</b>	<b>206</b>	<b>202</b>	<b>196</b>	<b>175</b>
[10]	[144]	[389]	[631]	[859]	[1098]	[1330]	[1562]	[1783]	[1993]	[2198]	[2687]
	16	44	71	97	124	150	176	201	225	248	304
<b>37,9</b>	<b>284</b>	<b>281</b>	<b>278</b>	<b>275</b>	<b>271</b>	<b>267</b>	<b>265</b>	<b>261</b>	<b>258</b>	<b>252</b>	<b>231</b>
[12]	[114]	[361]	[605]	[838]	[1075]	[1307]	[1532]	[1755]	[1965]	[2177]	[2671]
	13	41	68	95	121	148	173	198	222	246	302
<b>45,4</b>	<b>341</b>	<b>338</b>	<b>334</b>	<b>332</b>	<b>328</b>	<b>325</b>	<b>321</b>	<b>318</b>	<b>312</b>	<b>307</b>	<b>285</b>
[14]	[82]	[327]	[569]	[803]	[1042]	[1273]	[1498]	[1722]	[1935]	[2147]	[2655]
	9	37	64	91	118	144	169	195	219	243	300
<b>53,0</b>	<b>397</b>	<b>394</b>	<b>391</b>	<b>387</b>	<b>384</b>	<b>381</b>	<b>378</b>	<b>374</b>	<b>370</b>	<b>365</b>	<b>339</b>
Max. Continuous	[66]	[302]	[550]	[785]	[1025]	[1254]	[1480]	[1704]	[1915]	[2119]	[2648]
	7	34	62	89	116	142	167	193	216	239	299
<b>56,8</b>	<b>426</b>	<b>423</b>	<b>422</b>	<b>415</b>	<b>412</b>	<b>409</b>	<b>405</b>	<b>402</b>	<b>398</b>	<b>392</b>	<b>367</b>
Max. Inter-mittent	[20]	[177]	[429]	[678]	[908]	[1143]	[1375]	[1596]	[1811]	[2017]	
		20	48	77	103	129	155	180	205	228	
<b>75,7</b>		<b>565</b>	<b>560</b>	<b>556</b>	<b>553</b>	<b>549</b>	<b>546</b>	<b>541</b>	<b>536</b>	<b>527</b>	

[302] Torque [lb-in]  
34 Nm  
423 Speed RPM

Performance data is typical at 120 SUS. Actual data may vary slightly from unit to unit in production

# Performance Data T Series

Motors run with high efficiency in all areas designated with a number for torque and speed, however for best motor life select a motor to run with a torque and speed range shown in the light blue area.

157 cm<sup>3</sup>/r [9.6 in<sup>3</sup>/r]  
Δ Pressure Bar [PSI]  
Continuous

		[200]	[400]	[600]	[800]	[1000]	[1200]	[1400]	[1600]	[1800]	[2000]	Max. Continuous	Max. Inter-mittent
		14	28	41	55	69	83	97	110	124	138	[2500]	172
Flow LPM [GPM]	[2]	[264]	[541]	[819]	[1092]	[1357]	[1605]	[1847]	[2084]	[2311]	[1858]		
	7.6	30 47	61 45	93 44	123 42	153 40	181 37	209 34	235 30	261 25	210 16		
	[4]	[259]	[541]	[822]	[1101]	[1373]	[1638]	[1890]	[2145]	[2383]	[2613]	[3063]	
	15.1	29 96	61 95	93 92	124 91	155 90	185 88	214 85	242 82	269 78	295 73	346 60	
	[6]	[241]	[526]	[808]	[1090]	[1368]	[1638]	[1900]	[2150]	[2399]	[2628]	[3169]	
	22.7	27 142	59 140	91 138	123 136	155 134	185 132	215 129	243 125	271 121	297 114	358 99	
	[8]	[219]	[506]	[789]	[1068]	[1348]	[1625]	[1885]	[2140]	[2388]	[2619]	[3178]	
	30.3	25 189	57 187	89 185	121 183	152 181	184 178	213 175	242 172	270 166	296 159	359 140	
	[10]	[180]	[472]	[759]	[1037]	[1319]	[1590]	[1853]	[2111]	[2355]	[2594]	[3170]	
	37.9	20 237	53 234	86 232	117 230	149 227	180 224	209 222	239 218	266 211	293 203	358 183	
[12]	[141]	[436]	[728]	[1010]	[1292]	[1561]	[1821]	[2079]	[2331]	[2573]	[3162]		
45.4	16 284	49 282	82 279	114 277	146 274	176 272	206 269	235 265	263 257	291 248	357 225		
[14]	[101]	[397]	[687]	[969]	[1252]	[1519]	[1778]	[2040]	[2295]	[2539]	[3147]		
53.0	11 332	45 329	78 326	109 323	141 321	172 319	201 316	230 311	259 305	287 296	356 274		
[15]	[81]	[367]	[665]	[944]	[1231]	[1497]	[1755]	[2018]	[2273]	[2512]	[3136]		
Max. Continuous	56.8	9 355	41 353	75 350	107 347	139 344	169 342	198 339	228 334	257 327	284 318	354	300
Max. Inter-mittent	75.7	[20]	[221]	[519]	[814]	[1095]	[1368]	[1631]	[1891]	[2149]	[2396]		
			25 472	59 467	92 464	124 462	155 459	184 455	214 450	243 443	271 433		

195 cm<sup>3</sup>/r [11.9 in<sup>3</sup>/r]  
Δ Pressure Bar [PSI]  
Continuous

		[200]	[400]	[600]	[800]	[1000]	[1200]	[1400]	[1600]	[1750]	[1800]	[2000]	Max. Continuous	Max. Inter-mittent
		14	28	41	55	69	83	97	110	121	125	138	[2500]	172
Flow LPM [GPM]	[2]	[330]	[671]	[1016]	[1345]	[1654]	[1969]	[2242]	[2507]	[2689]	[2748]	[2973]		
	7.6	37 38	76 36	115 34	152 33	187 31	222 28	253 25	283 20	304 16	310 14	336 8		
	[4]	[328]	[675]	[1026]	[1366]	[1692]	[2010]	[2289]	[2586]	[2799]	[2867]	[3144]	[3797]	
	15.1	37 77	76 77	116 75	154 73	191 73	227 71	259 68	292 65	316 62	324 61	355 55	429 40	
	[6]	[306]	[658]	[1011]	[1360]	[1698]	[2021]	[2324]	[2604]	[2829]	[2901]	[3178]	[3831]	
	22.7	35 115	74 113	114 111	154 110	192 109	228 107	263 104	294 100	320 97	328 95	359 87	433 68	
	[8]	[272]	[634]	[980]	[1331]	[1675]	[2003]	[2300]	[2592]	[2815]	[2888]	[3174]	[3864]	
	30.3	31 153	72 151	111 150	150 148	189 146	226 144	260 142	293 139	318 134	326 132	359 123	437 99	
	[10]	[238]	[596]	[945]	[1296]	[1637]	[1960]	[2255]	[2565]	[2786]	[2857]	[3140]	[3816]	
	37.9	27 192	67 189	107 188	146 186	185 184	221 183	255 181	290 176	315 168	323 166	355 156	431 133	
[12]	[181]	[545]	[908]	[1260]	[1607]	[1924]	[2223]	[2529]	[2759]	[2836]	[3121]	[3807]		
45.4	20 230	62 228	103 226	142 222	182 221	217 219	251 213	286 207	312 207	320 204	353 192	430 160		
[14]	[154]	[500]	[860]	[1211]	[1556]	[1869]	[2175]	[2483]	[2713]	[2792]	[3080]	[3778]		
53.0	17 268	56 266	97 264	137 261	176 259	211 259	246 256	281 251	307 244	315 242	348 229	427 199		
[15]	[140]	[465]	[832]	[1179]	[1525]	[1835]	[2144]	[2459]	[2693]	[2768]	[3061]	[3764]		
Max. Continuous	56.8	16 287	53 285	94 283	133 281	172 279	207 278	242 275	278 269	304 262	313 260	346 247	425	220
Max. Inter-mittent	75.7	[20]	[291]	[653]	[1013]	[1366]	[1689]	[1987]	[2298]	[2540]	[2622]	[2928]		
			33 382	74 378	114 375	154 373	191 372	225 368	260 363	287 356	296 353	331 342		

[465] Torque [lb-in]  
53 Nm  
285 Speed RPM

Performance data is typical at 120 SUS. Actual data may vary slightly from unit to unit in production

# Performance Data T Series

Motors run with high efficiency in all areas designated with a number for torque and speed, however for best motor life select a motor to run with a torque and speed range shown in the light blue area.

		244 cm <sup>3</sup> /r [14.9 in <sup>3</sup> /r]											Max. Contin-uous	Max. Inter-mittent	
		Δ Pressure Bar [PSI]													
		[200]	[400]	[600]	[800]	[1000]	[1200]	[1400]	[1600]	[1650]	[1800]	[1850]	[2250]		
		14	28	41	55	69	83	97	110	114	125	127	155		
Flow LPM [GPM]	[2]	[406]	[833]	[1260]	[1655]	[2038]	[2403]	[2707]	[2597]	[2552]	[2373]	[2299]			
	7.6	46	94	142	187	230	272	306	293	288	268	260			
		30	29	27	26	24	22	17	12	11	7	6			
	[4]	[404]	[843]	[1277]	[1695]	[2083]	[2468]	[2820]	[3177]	[3261]	[3509]	[3589]	[4194]		
	15.1	46	95	144	192	235	279	319	359	368	396	406	474		
		62	62	60	59	59	57	55	50	49	46	46	35		
	[6]	[382]	[823]	[1261]	[1687]	[2088]	[2477]	[2843]	[3196]	[3285]	[3547]	[3633]	[4290]		
	22.7	43	93	142	191	236	280	321	361	371	401	410	485		
		92	91	90	89	88	86	82	78	76	72	71	60		
	[8]	[341]	[787]	[1220]	[1651]	[2059]	[2454]	[2820]	[3177]	[3265]	[3530]	[3615]	[4285]		
30.3	39	89	138	187	233	277	319	359	369	399	408	484			
	123	122	121	120	119	116	113	108	106	101	99	85			
[10]	[297]	[744]	[1177]	[1611]	[2017]	[2412]	[2774]	[3151]	[3241]	[3504]	[3593]	[4269]			
37.9	34	84	133	182	228	273	313	356	366	396	406	482			
	154	152	151	150	148	146	143	136	134	127	125	107			
[12]	[225]	[687]	[1132]	[1553]	[1967]	[2360]	[2734]	[3105]	[3194]	[3466]	[3554]	[4237]			
45.4	25	78	128	175	222	267	309	351	361	392	402	479			
	184	183	181	180	179	177	173	166	163	156	153	134			
[14]	[154]	[628]	[1072]	[1498]	[1910]	[2298]	[2674]	[3052]	[3148]	[3419]	[3510]	[4226]			
53.0	17	71	121	169	216	260	302	345	356	386	397	477			
	214	213	212	211	209	207	202	195	193	185	182	161			
Max. Contin-uous	[15]	[119]	[586]	[1035]	[1458]	[1872]	[2261]	[2637]	[3022]	[3116]	[3389]	[3488]	[4220]		
	13	66	117	165	212	255	298	341	352	383	394	477			
	229	228	227	226	224	222	217	209	207	200	197	174			
Max. Inter-mittent	[20]		[372]	[816]	[1251]	[1663]	[2067]	[2448]	[2832]	[2928]	[3214]	[3312]			
	75.7		42	92	141	188	234	277	320	331	363	374			
			305	303	301	300	297	292	284	281	273	270			

		306 cm <sup>3</sup> /r [18.7 in <sup>3</sup> /r]										Max. Contin-uous	Max. Inter-mittent
		Δ Pressure Bar [PSI]											
		[200]	[400]	[600]	[800]	[1000]	[1200]	[1400]	[1500]	[1600]	[1800]		
		14	28	41	55	69	83	97	103	110	124		
Flow LPM [GPM]	[2]	[499]	[1035]	[1560]	[2034]	[2501]	[2912]	[3239]	[2859]	[2400]			
	7.6	56	117	176	230	283	329	366	323	271			
		24	23	22	21	19	16	11	8	5			
	[4]	[497]	[1052]	[1590]	[2101]	[2561]	[3023]	[3464]	[3680]	[3886]	[4221]		
	15.1	56	119	180	237	289	342	391	416	439	477		
		49	49	48	48	47	47	44	41	38	30		
	[6]	[480]	[1031]	[1578]	[2096]	[2564]	[3023]	[3464]	[3689]	[3905]	[4275]		
	22.7	54	116	178	237	290	342	391	417	441	483		
		74	74	72	72	71	69	64	62	60	51		
	[8]	[427]	[975]	[1520]	[2051]	[2525]	[2998]	[3448]	[3667]	[3881]	[4264]		
30.3	48	110	172	232	285	339	390	414	438	482			
	99	98	97	97	96	94	89	86	83	73			
[10]	[370]	[930]	[1467]	[2001]	[2477]	[2955]	[3406]	[3631]	[3852]	[4264]			
37.9	42	105	166	226	280	334	385	410	435	482			
	123	122	121	120	120	117	112	108	104	92			
[12]	[281]	[871]	[1410]	[1908]	[2400]	[2887]	[3352]	[3573]	[3790]	[4189]			
45.4	32	98	159	216	271	326	379	404	428	473			
	147	146	145	145	145	142	136	131	127	112			
[14]	[192]	[791]	[1338]	[1851]	[2338]	[2816]	[3281]	[3511]	[3743]	[4135]			
53.0	22	89	151	209	264	318	371	397	423	467			
	171	171	170	170	169	165	159	154	150	133			
Max. Contin-uous	[15]	[148]	[738]	[1288]	[1803]	[2287]	[2773]	[3243]	[3475]	[3705]	[4098]		
	17	83	146	204	258	313	366	393	419	463	463		
	183	183	182	182	181	177	171	165	160	146	146		
Max. Inter-mittent	[20]		[476]	[1020]	[1544]	[2010]	[2519]	[3010]	[3243]	[3495]			
	75.7		54	115	174	227	285	340	366	395			
			243	242	242	241	238	231	226	209			

[738]  
83 } Torque [lb-in]  
183 } Nm  
Speed RPM

		370 cm <sup>3</sup> /r [22.6 in <sup>3</sup> /r]										Max. Contin-uous	Max. Inter-mittent
		Δ Pressure Bar [PSI]											
		[200]	[400]	[600]	[800]	[1000]	[1200]	[1300]	[1500]	[1800]			
		14	28	41	55	69	83	90	103	110	124		
Flow LPM [GPM]	[2]	[590]	[1237]	[1858]	[2406]	[2953]	[3388]	[3586]					
	7.6	67	140	210	272	334	383	405					
		20	19	18	17	15	12	11					
	[4]	[588]	[1263]	[1906]	[2506]	[3029]	[3557]	[3811]	[4252]				
	15.1	66	143	215	283	342	402	431	480				
		41	41	40	40	39	38	37	36				
	[6]	[580]	[1245]	[1899]	[2506]	[3029]	[3544]	[3788]	[4300]				
	22.7	66	141	215	283	342	400	428	486				
		61	60	60	59	58	57	56	54				
	[8]	[514]	[1164]	[1824]	[2452]	[2975]	[3518]	[3783]	[4284]				
30.3	58	132	206	277	336	397	427	484					
	82	81	80	79	78	77	77	75					
[10]	[444]	[1119]	[1759]	[2391]	[2928]	[3479]	[3750]	[4275]					
37.9	50	126	199	270	331	393	424	483					
	102	102	101	101	100	97	96	93					
[12]	[337]	[1062]	[1690]	[2256]	[2813]	[3393]	[3685]	[4273]					
45.4	38	120	191	265	318	383	416	483					
	122	121	120	119	119	118	116	112					
[14]	[231]	[958]	[1608]	[2201]	[2748]	[3319]	[3610]	[4198]					
53.0	26	108	182	249	310	375	408	474					
	142	141	140	139	138	137	134	129					
Max. Contin-uous	[15]	[178]	[896]	[1543]	[2147]	[2683]	[3272]	[3572]	[4187]				
	20	101	174	243	303	370	404	473					
	152	152	151	150	149	147	146	140					
Max. Inter-mittent	[20]		[587]	[1228]	[1833]	[2331]	[2948]	[3273]					
	75.7		66	139	207	263	333	370					
			202	201	201	200	198	196					

Performance data is typical at 120 SUS. Actual data may vary slightly from unit to unit in production

# Dimensions T Series

Note: Mounting Surface Flatness Requirement is  $\nabla$  ,13 mm [.005 inch] Max.

## 2 Bolt Flange

Standard Rotation  
Viewed from Shaft End  
Port A Pressurized — CW  
Port B Pressurized — CCW

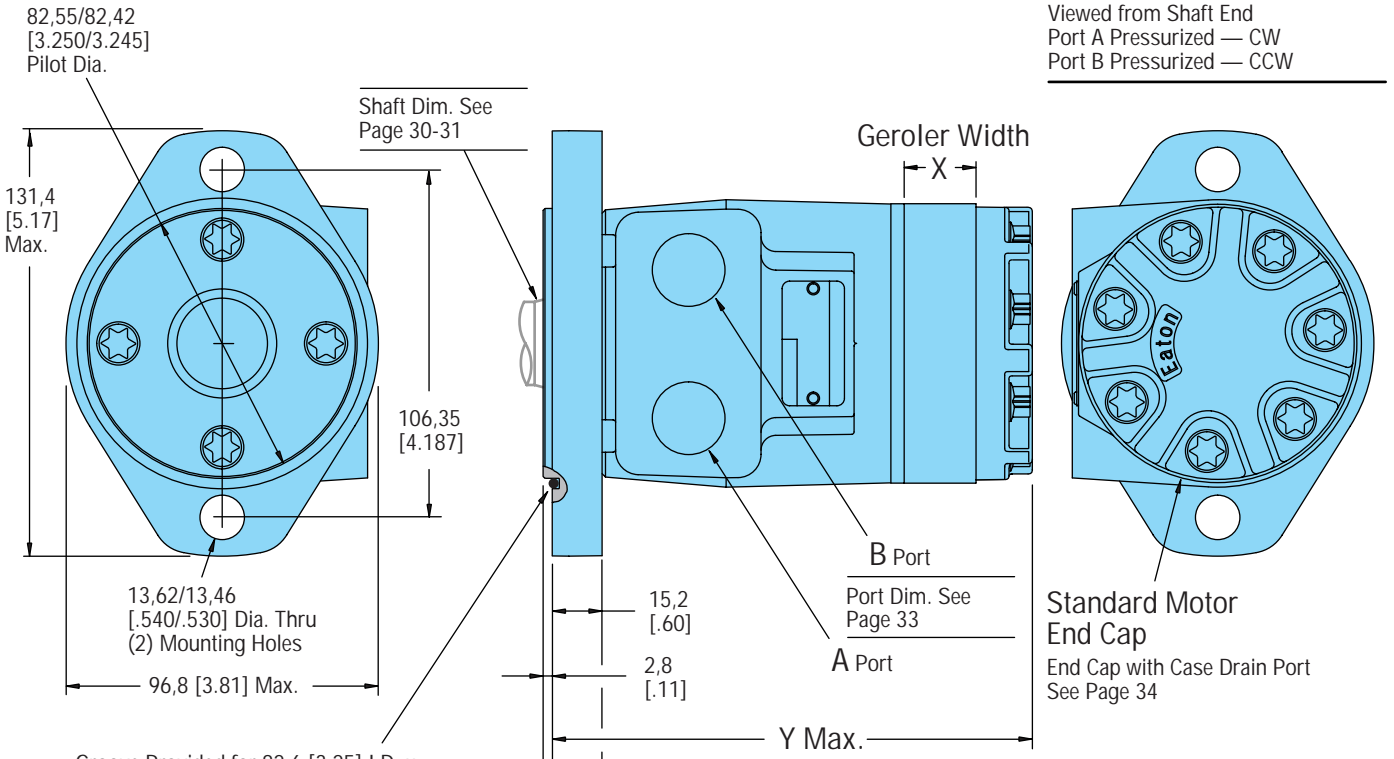

## 4 Bolt Flange

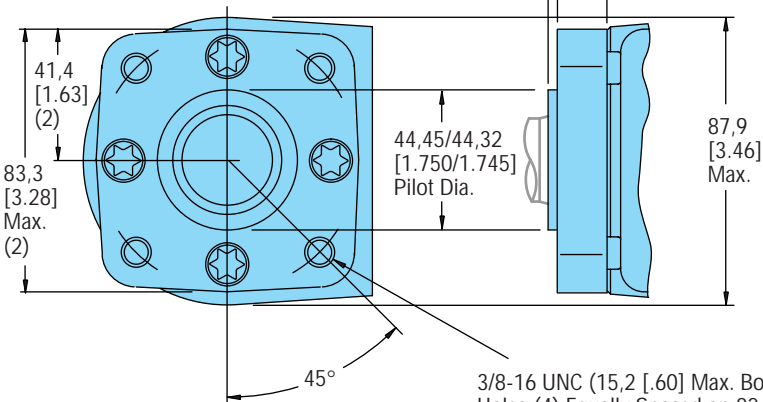

Displ. cm <sup>3</sup> /r [in <sup>3</sup> /r]	X	Y Max.
	Width mm [in.]	Length mm [in.]
36 [ 2.2]	6,6 [ .26]	132,2 [5.21]
49 [ 3.0]	9,1 [ .36]	134,6 [5.30]
66 [ 4.0]	12,2 [ .48]	137,7 [5.42]
80 [ 4.9]	14,7 [ .58]	140,3 [5.53]
102 [ 6.2]	18,5 [ .73]	144,3 [5.68]
131 [ 8.0]	24,1 [ .95]	149,6 [5.89]
157 [ 9.6]	29,0 [1.14]	154,5 [6.09]
195 [11.9]	35,6 [1.40]	161,3 [6.35]
244 [14.9]	44,7 [1.76]	170,3 [6.71]
306 [18.7]	56,1 [2.21]	181,6 [7.16]
370 [22.6]	72,1 [2.84]	197,9 [7.79]

3/8-16 UNC (15,2 [.60] Max. Bolt Thread Engagement ) Mounting Holes (4) Equally Spaced on 82,6 [3.25] Dia. Bolt Circle  
or  
M10 x 1,5 (15,2 [.60] Max. Bolt Thread Engagement ) Mounting Holes (4) Equally Spaced on 82,6 [3.25] Dia. Bolt Circle

# Product Numbers T Series 158-xxxx

## Product Numbers—T Series

Add three digit prefix —158—to four digit number from chart for complete product number—Example 158-1068.  
Orders will not be accepted without three digit prefix.

Mounting	Shaft	Ports	Displ. cm <sup>3</sup> /r [in <sup>3</sup> /r] Product Number 158-xxxx											
			36 [ 2.2]	49 [ 3.0]	66 [ 4.0]	80 [ 4.9]	102 [ 6.2]	131 [ 8.0]	157 [ 9.6]	195 [11.9]	244 [14.9]	306 [18.7]	370 [22.6]	
2 Bolt Flange	1 in. Straight w/Woodruff Key	7/8-14 O-ring	158-	—	—	-1537	-1034	-1035	-1538	-1036	-1037	-1038	-1039	-1040
		1/2 NPTF	158-	—	—	-1540	-1026	-1027	-1541	-1028	-1029	-1030	-1031	-1032
		Manifold*	158-	—	—	-1543	-1042	-1043	-1544	-1044	-1045	-1046	-1047	-1048
	1 in. SAE 6B Splined	7/8-14 O-ring	158-	—	—	-1552	-1082	-1083	-1553	-1084	-1085	-1086	-1087	-1088
		1/2 NPTF	158-	—	—	-1555	-1074	-1075	-1556	-1076	-1077	-1078	-1079	-1080
		Manifold*	158-	—	—	-1558	-1090	-1091	-1559	-1092	-1093	-1094	-1095	-1096
4 Bolt Flange	1 in. Straight w/Woodruff Key	7/8-14 O-ring	158-	—	—	-1570	-1010	-1011	-1571	-1012	-1013	-1014	-1015	-1016
		1/2 NPTF	158-	—	—	-1573	-1002	-1003	-1574	-1004	-1005	-1006	-1007	-1008
		Manifold*	158-	—	—	-1576	-1018	-1019	-1577	-1020	-1021	-1022	-1023	-1024
	1 in. SAE 6B Splined	7/8-14 O-ring	158	—	—	-1579	-1058	-1059	-1580	-1060	-1061	-1062	-1063	-1064
		1/2 NPTF	158-	—	—	-1582	-1050	-1051	-1583	-1052	-1053	-1054	-1055	-1056
		Manifold*	158-	—	—	-1585	-1066	-1067	-1586	-1068	-1069	-1070	-1071	-1072

\*Manifold product numbers shown are for motors with four 5/16-18 port face mounting threads. Manifold, manifold mounting o-rings and bolts are NOT included (for M8 x 1,5 port face mounting threads see note below).

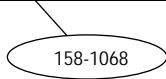

## Product Numbers—T Series Motors with Corrosion Protection

Shaft	Mounting	Ports	Displ. cm <sup>3</sup> /r [cu. in <sup>3</sup> /r] Product Number 158-xxxx											
			36 [ 2.2]	49 [ 3.0]	66 [ 4.0]	80 [ 4.9]	102 [ 6.2]	131 [ 8.0]	157 [ 9.6]	195 [11.9]	244 [14.9]	306 [18.7]	370 [22.6]	
1 in. Straight w/Woodruff Key	2 Bolt Flange	7/8-14 O-ring	158-	—	—	—	-1645	—	—	—	—	-1649	—	-1650
	4 Bolt Flange	1/2 NPTF	158-	—	—	—	—	—	—	—	—	-1620	—	-1621

For T Series Motors with a configuration Not Shown in the charts above: Use the model code number system on page 39 to specify the product in detail.

For Product Numbers—T Series Motors with Low Speed Valving — See Page 28.

# Specifications H, S Series and T Series with Low Speed Valving — Product Numbers

## S Series and T Series w/LSV

These motors with the low speed valving option provide very low speed while maintaining high torque. Designed to run continuously at up to 200 RPM at standard rated pressures and reduced flows, providing smooth operation at low speeds. Furthermore, they resist slippage and have more momentary load holding ability than the standard H, and S Series motors. Motors with this valving are not intended for low pressure applications (41 Bar [600 PSI] Minimum). Shaft side / radial load ratings are not affected by this valving.

For H Series Motors with Low Speed Valving — Use the model code number system on page 37 to specify the product in detail.

### Product Numbers—S Series Motors with Low Speed Valving

Mounting	Shaft	Ports	Displ. cm <sup>3</sup> /r [in <sup>3</sup> /r] Product Number 103-xxxx										
			59 [ 3.6]	74 [ 4.5]	97 [ 5.9]	120 [ 7.3]	146 [ 8.9]	159 [ 9.7]	185 [11.3]	231 [14.1]	293 [17.9]	370 [22.6]	
2 Bolt Flange	1 in. Straight w/Woodruff Key	7/8-14 O-ring	103-	—	-1427	-1428	—	—	-1429	-1430	-1431	-1432	-1433
		1/2 NPTF	103-	—	-1419	-1420	—	—	-1421	-1422	-1423	-1424	-1425
		Manifold*	103-	—	—	—	—	—	—	—	—	—	—
	1 in. SAE 6B Splined	7/8-14 O-ring	103-	—	-1525	—	—	-2692	—	—	-1675	—	—
		1/2 NPTF	103-	—	—	-1634	—	—	—	—	—	—	—
		Manifold*	103-	—	-1522	-2678	—	—	—	—	—	—	-1527
4 Bolt Flange	1 in. Straight w/Woodruff Key	7/8-14 O-ring	103-	-1625	-1410	-1411	-1626	-2531	-1412	-1413	-1414	-1415	-1416
		1/2 NPTF	103-	-1644	-1402	-1403	—	—	-1404	-1405	-1406	-1407	-1408

\*Manifold product numbers shown are for motors with four 5/16-18 port face mounting threads. Manifold, manifold mounting o-rings and bolts are NOT included (for M8 x 1,5 port face mounting threads see note below).

For S Series Motors with Low Speed Valving Not Shown in the chart above: Use the model code number system on page 38 to specify the product in detail.

### Product Numbers—T Series Motors with Low Speed Valving

Mounting	Shaft	Ports	Displ. cm <sup>3</sup> /r [in <sup>3</sup> /r] Product Number 158-xxxx											
			36 [ 2.2]	49 [ 3.0]	66 [ 4.0]	80 [ 4.9]	102 [ 6.2]	131 [ 8.0]	157 [ 9.6]	195 [11.9]	244 [14.9]	306 [18.7]	370 [22.6]	
2 Bolt Flange	1 in. Straight w/Woodruff Key	7/8-14 O-ring	158-	—	—	—	-1427	-1428	—	—	-1430	-1431	-1432	-1433
		1/2 NPTF	158-	—	—	—	-1419	-1420	—	—	-1422	-1423	-1424	-1425
		Manifold*	158-	—	—	—	—	—	—	—	—	—	—	—
	1 in. SAE 6B Splined	7/8-14 O-ring	158-	—	—	—	-1525	—	—	—	—	-1675	—	—
		1/2 NPTF	158-	—	—	—	—	-1634	—	—	—	—	—	—
		Manifold*	158-	—	—	—	-1522	-2678	—	—	—	—	—	-1527
4 Bolt Flange	1 in. Straight w/Woodruff Key	7/8-14 O-ring	158-	—	—	-1625	-1410	-1411	-1626	-1412	-1413	-1414	-1415	-1416
		1/2 NPTF	158-	—	—	-1644	-1402	-1403	—	-1404	-1405	-1406	-1407	-1408

\*Manifold product numbers shown are for motors with four 5/16-18 port face mounting threads. Manifold, manifold mounting o-rings and bolts are NOT included (for M8 x 1,5 port face mounting threads see note below).

For T Series Motors with Low Speed Valving Not Shown in the chart above: Use the model code number system on page 39 to specify the product in detail.

# Shaft Side Load Capacity H, S, Series and T Series

The hydrodynamic bearing has infinite life when shaft load ratings are not exceeded. Hence, the shaft side load capacity is more than adequate to handle most externally applied loads (such as belts, chains, etc.), providing the motor to shaft size is applied within its torque rating.

Allowable side load chart, shaft load location drawing and load curves (below) are based on the side / radial loads being applied to shaft at locations A, B, and C, to determine the shaft side load capacity at locations other than those shown use the formula (shown below). For more information about shaft side loads on Char-Lynn motors contact your Eaton representative.

Note: When the speed sensor option is used , the side load ratings are reduced 25%.

$$\text{Sideload P kg} = \frac{900}{N} \left( \frac{16800}{L + 96,3} \right) \quad \text{for 200-900 RPM}$$

$$\text{Sideload P [lb]} = \frac{900}{N} \left( \frac{1460}{L + [3.79]} \right) \quad \text{for 200-900 RPM}$$

Where N = Shaft Speed (RPM)

L = Distance from Mounting Surface

RPM	Allowable Shaft Side Load —Kg [lb]		
	A	B	C
900	154 [ 339]	136 [ 300]	118 [ 261]
625	205 [ 452]	181 [ 400]	158 [ 348]
500	256 [ 565]	227 [ 500]	197 [ 435]
400	307 [ 678]	272 [ 600]	237 [ 522]
300	410 [ 904]	363 [ 800]	316 [ 696]
200	718 [1582]	635 [1400]	552 [1216]

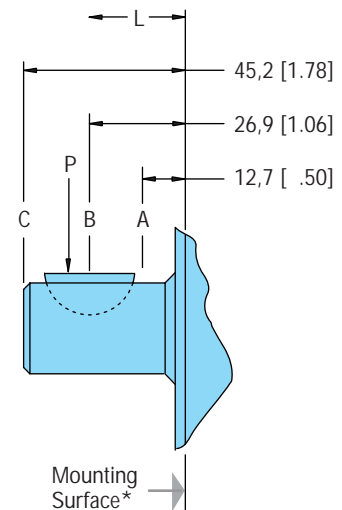

\*2 Bolt SAE B mounting flange has a greater pilot thickness and a thinner mounting plate (end of shaft to flange, add 3,3 [.13]).

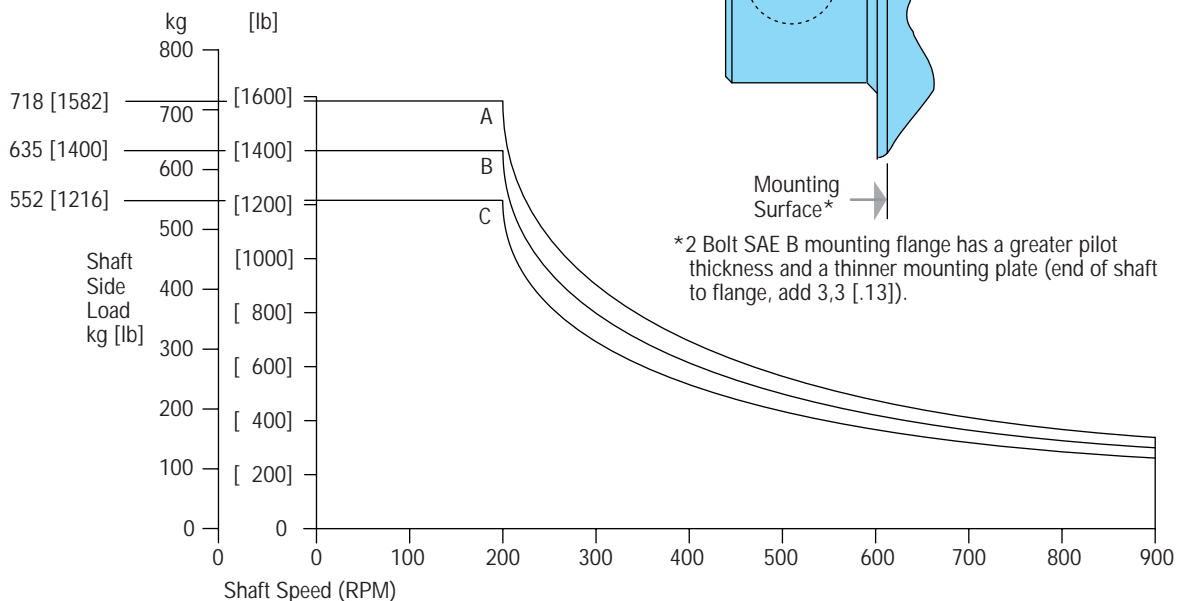

# Dimensions — Shafts

## H, S, and T Series

Shaft Size /Motor Torque Combination Limit Guide

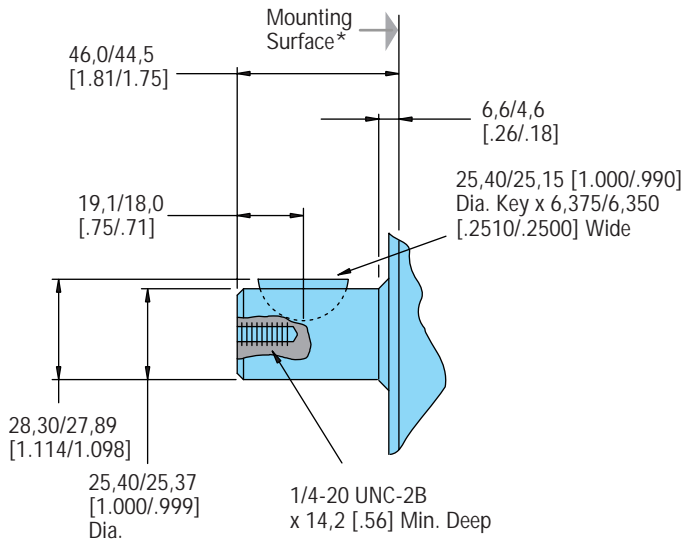
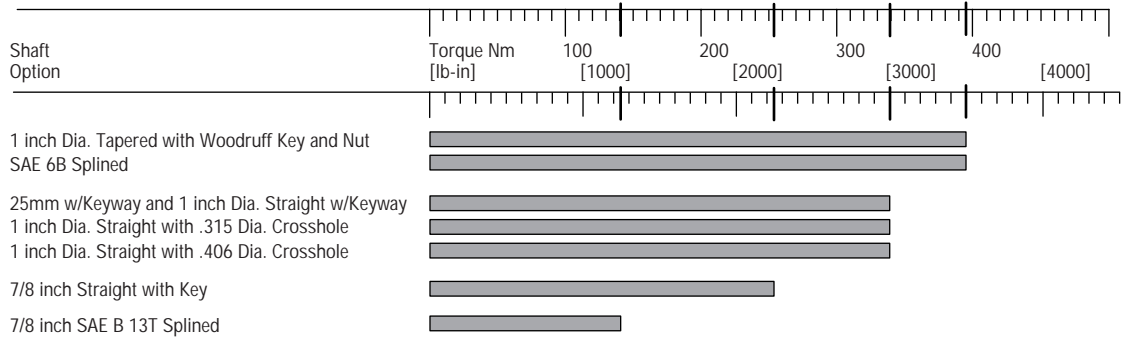

1 in. Dia. Straight with Woodruff Key

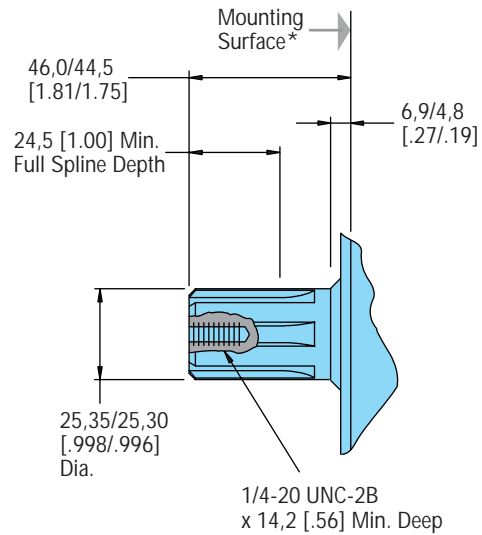

SAE 6B Splined Shaft

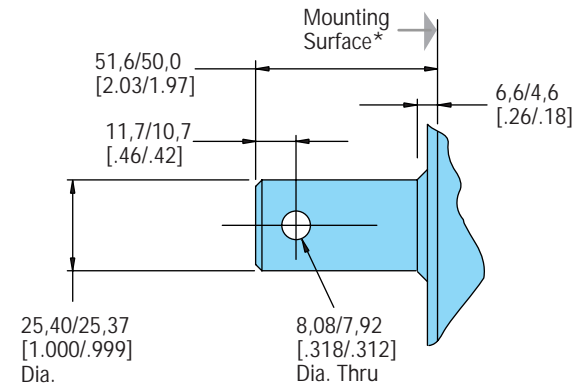

1 in. Dia. Straight Shaft with .315 Dia. Crosshole

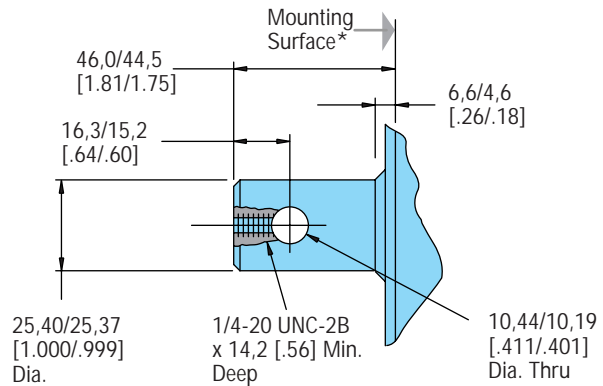

1 in. Dia. Straight Shaft with .406 Dia. Crosshole

\*2 Bolt SAE B mounting flange has a greater pilot thickness and a thinner mounting plate (end of shaft to flange, add 3,3 [.13]).

# Dimensions — Shafts

## H, S and T Series

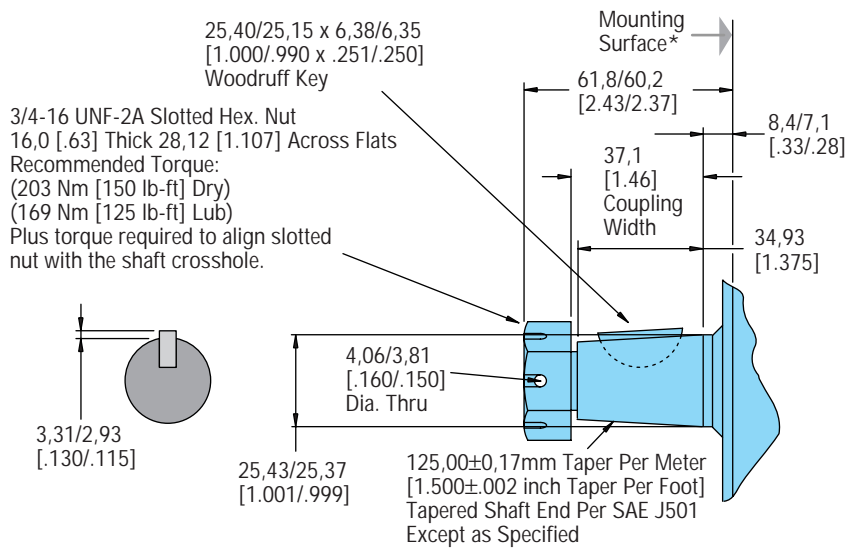

1 in. Dia. Tapered Shaft with Woodruff Key and Nut

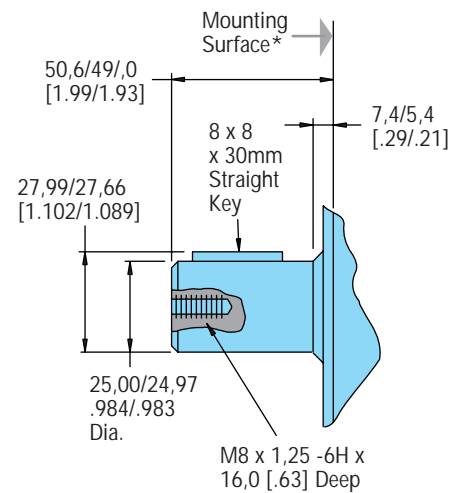

25mm Dia. Straight Shaft with 8mm Keyway

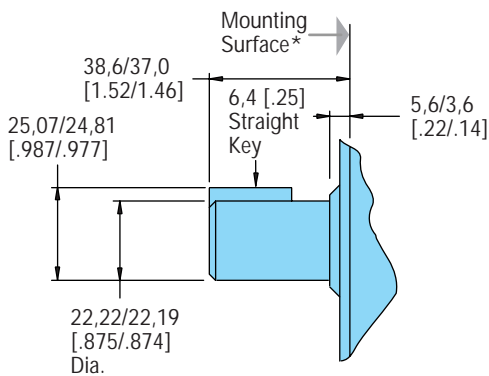

7/8 in. Dia. Straight Shaft with Key

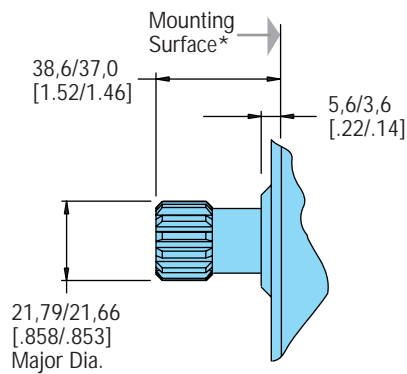

7/8 in. Dia. SAE B Shaft 13 T Splined

\*2 Bolt SAE B mounting flange has a greater pilot thickness and a thinner mounting plate (end of shaft to flange, add 3,3 [.13]).

# Dimensions — Mounting Options H, S, and T Series

Note: Mounting Surface Flatness Requirement is  $\nabla$ , 13 mm [.005 inch] Max.

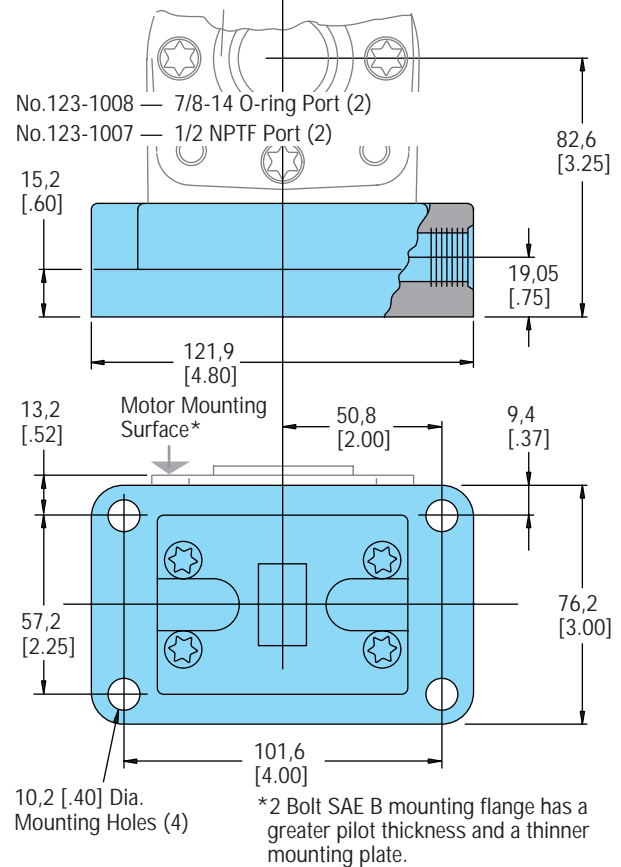
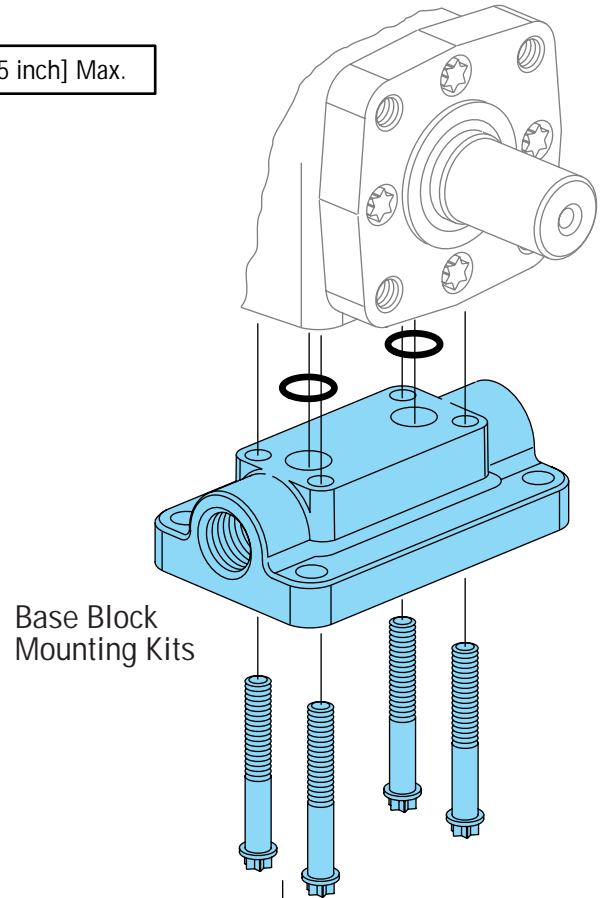
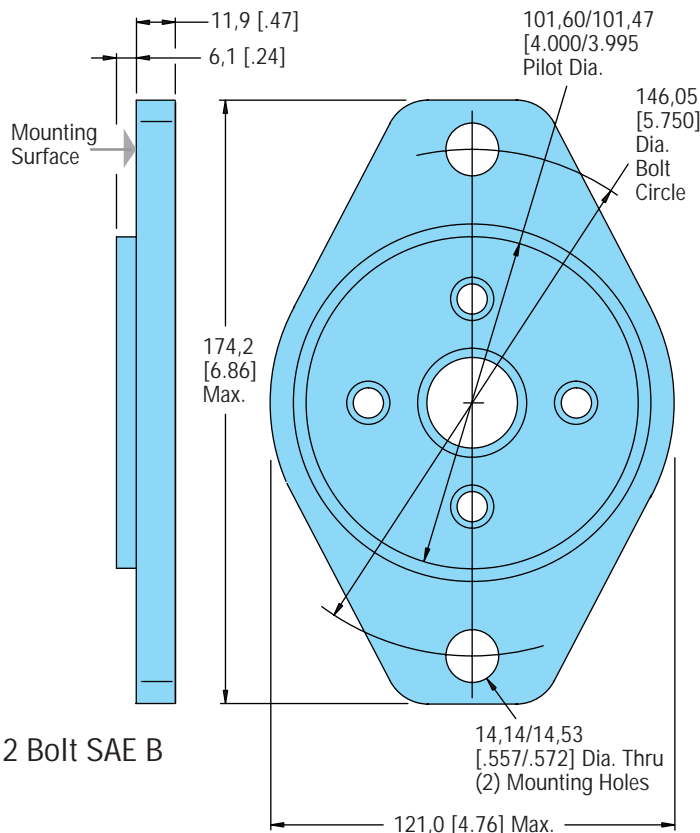
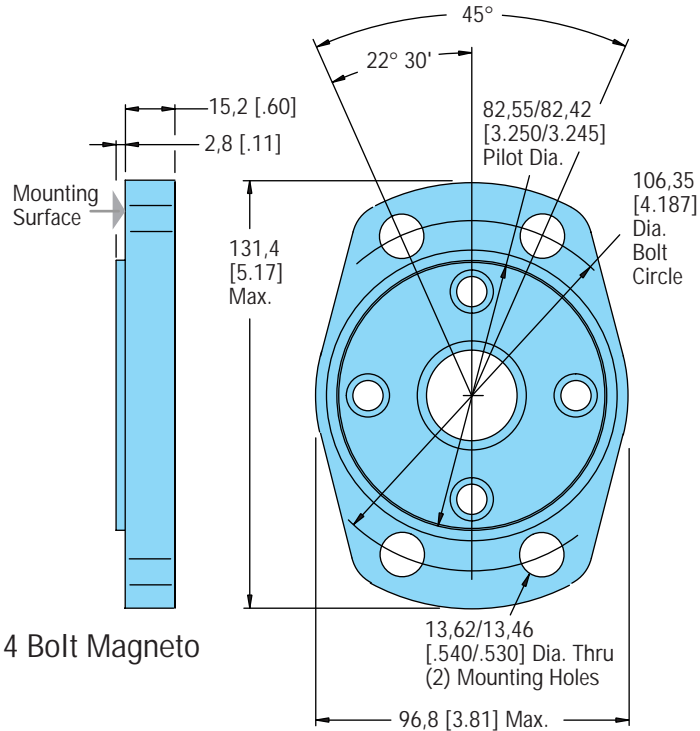

# Dimensions — Ports H, S, and T Series

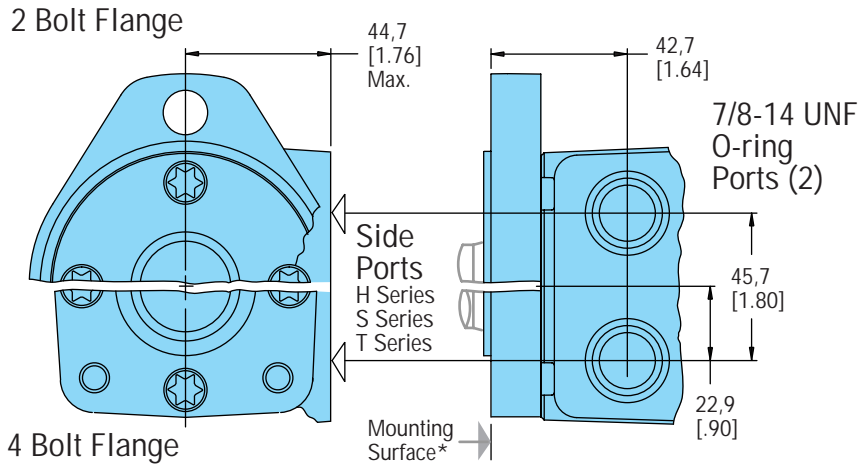

## End Ports — H Series G 1/2 (BSP) (2) or 3/4-16 O-ring (2)

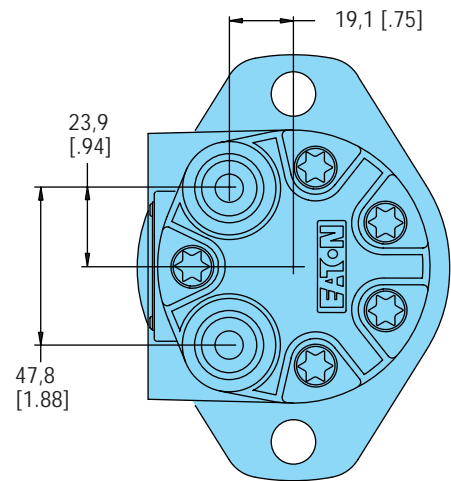

Use of Teflon Tape Sealant/Lubricant (with 1/2 14 NPTF Port Connectors only).  
When using fittings with Teflon tape, be careful when taping and tightening. Over tightening or

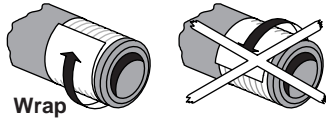

improperly taped fittings can cause damage to housing or leakage.

Use the following procedures:

- Wrap approx. 1 1/2 Turns of 13 mm [1/2 in.] wide Teflon Tape around fitting threads — start tape 2 threads up from end of fitting.
- Tighten threads to a Maximum of 34 Nm [25 lb-ft]. — **Do Not Tighten Further** —
- If fittings leak when tightened to maximum torque, either retape, reseal, or replace fittings.

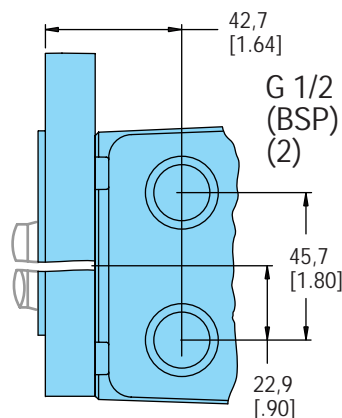
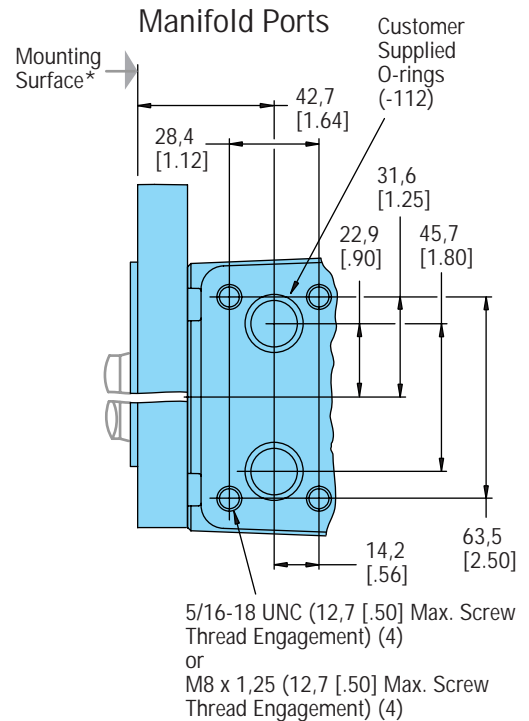
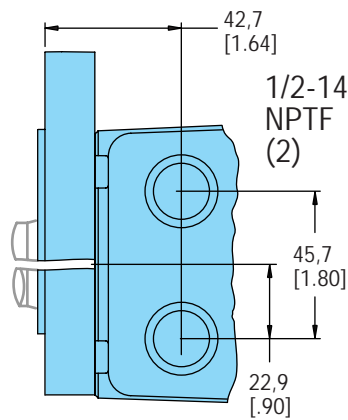

\*2 Bolt SAE B mounting flange has a greater pilot thickness and a thinner mounting plate.

# Case Pressure and Case Drain — H, S, and T Series

## Series or Parallel Connection

Hydraulic lines bringing pressurized fluid from the pump to the motor and return flow from the motor back to tank can be flexible or rigid. One pump can be sized to supply a single motor or many motors. Furthermore, one pump and multiple motors can be connected in series or in parallel (see each type of connection shown below). When connecting the pump to the motors in series excess internal case pressure is created in the motor, this excess pressure must be ported back to tank. However, when making a parallel connection from the pump to the motors no excess case pressure will be added. Hence, using the case drain ports are not necessary. Meanwhile, take a look at the application and see if this optional case drain port can be connected to your advantage, whether it be a single motor to pump connection, multiple motors connected to pump in parallel, as well as multiple motors connected to pump in series...

...Case Drain Advantage — In addition to providing lower case pressures for motors connected in series, there are advantages for adding an external case drain line to motors with normal case pressures as well. These advantages are: Contamination Control — flushing the motor case. Cooler System — exiting oil draws motor heat away. Extend Motor Seal Life — maintain low case pressure with a preset restriction installed in the case drain line (see page 35).

Motors ordered with case drain port will be shipped with steel hex socket plug installed in that end cap drain port.

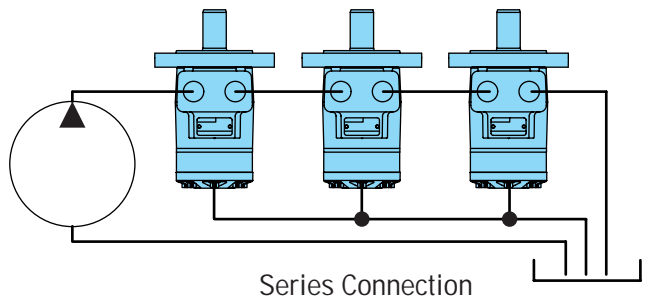
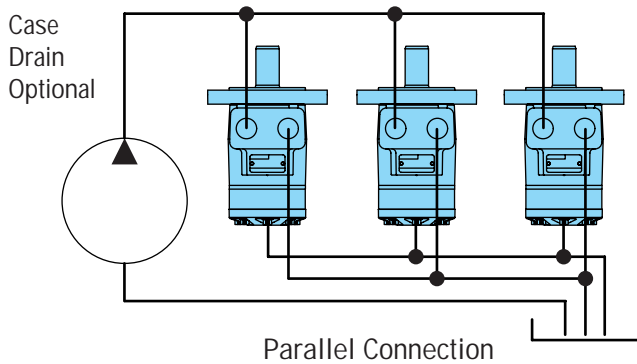

H Series with Case Drain Port — G 1/4 (BSP) or 7/16-20 O-ring

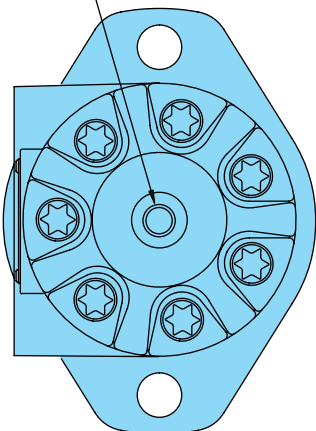

H Series with End Ports and Case Drain Port — G 1/4 (BSP) or 7/16-20 O-ring

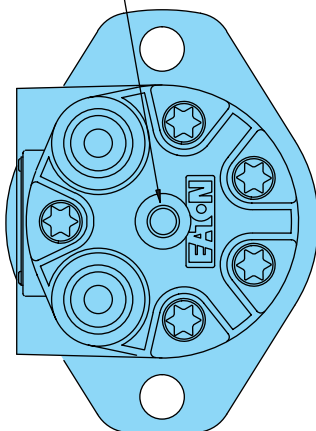

S Series with Case Drain Port — G 1/4 (BSP) or 7/16-20 O-ring

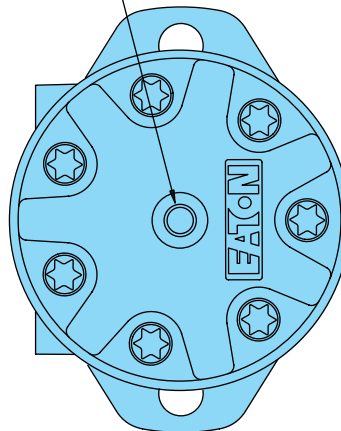

T Series with Case Drain Port — G 1/4 (BSP) or 7/16-20 O-ring

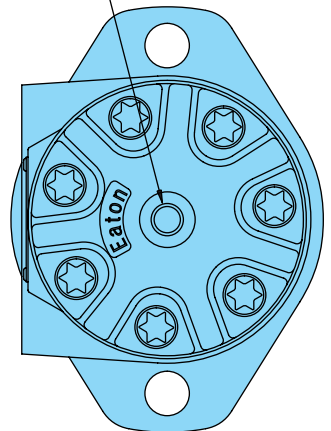

## Case Pressure and Case Drain — H, S, and T Series

Char-Lynn H Series, S Series and T Series motors are durable and have long life as long as the recommended case pressure is not exceeded. Allowable case pressure is highest at low shaft speeds. Consequently, motor life will be shortened if case pressure exceeds these ratings (acceptability may vary with application). Determine if an external case drain is required from the case pressure seal limitation chart below — chart based on case pressure and shaft speed. If a case drain line is needed, connect drain line to assure that the motor will always remain full of fluid. A pressure restriction should be added to the case drain line, during which a motor case pressure of 3,5 Bar [50 PSI] is maintained.

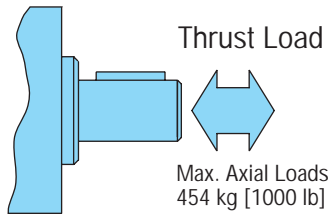
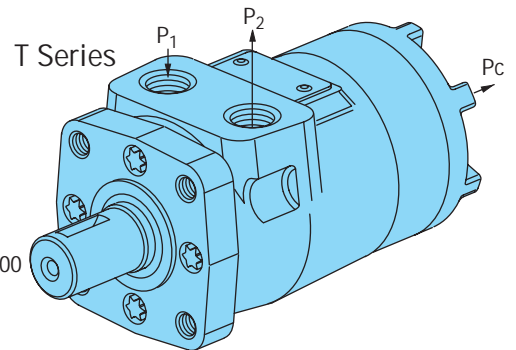
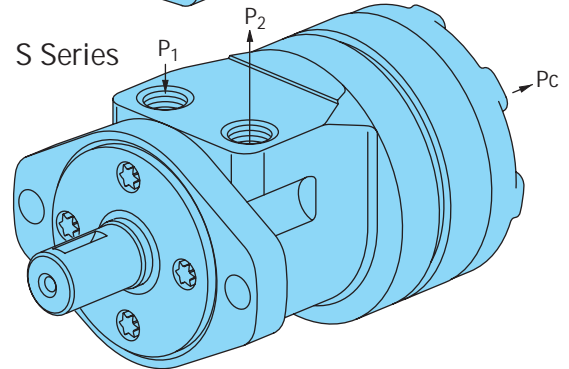
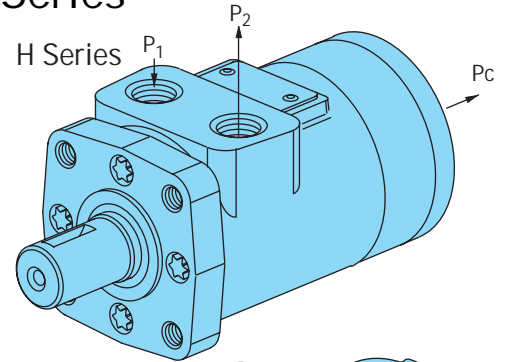

$$P_C \approx .6\Delta P + P_2$$

$P_C$  = Case Pressure  
 $P_1$  = Inlet Line Pressure  
 $P_2$  = Back Pressure  
 $\Delta P = P_1 - P_2$

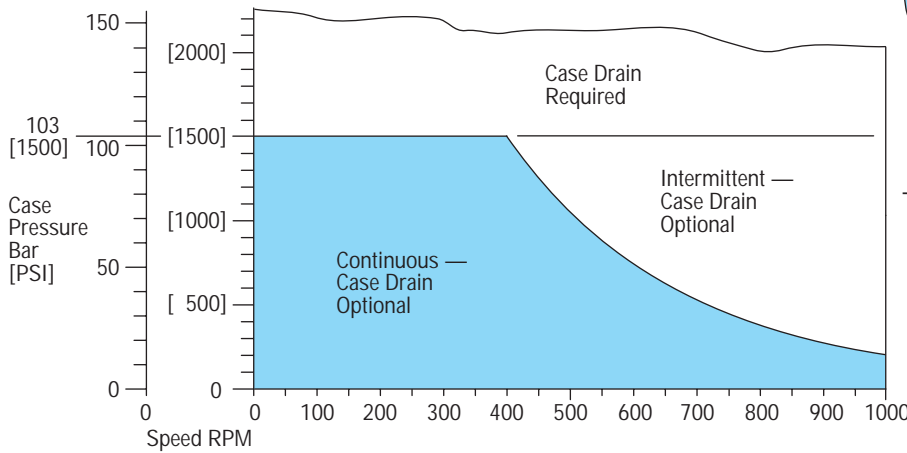

## Speed Sensor — H Series and T Series

Eaton has developed a speed sensor specifically designed for LSHT motors. The design is rugged and fully protected against accidental reverse polarity or short circuit hookup. A built-in pull-up resistor simplifies installation with control systems.

This sensor is fully compatible with mobile vehicle electrical systems and gives a reliable digital on/off signal over a wide speed range and temperature range.

Supply Voltage: 8 to 24 Vdc (compatible with 12V vehicle systems)  
 Supply Current: 20 mA max. (Vs) (including internal pull-up resistor)  
 Output Voltage: Low < .5 Vdc @ 10 mA; output is open collector with 10kΩ pull-up resistor  
 Connection — std. 3 prong Weatherpack connector with 18 AWG (american wire gage) cables:  
 Position A (red) = power supply Position B (wht) = signal output Position C (blk) = common  
 Output — digital on/off signal from Hall Effect switch; 15 pulses /revolution

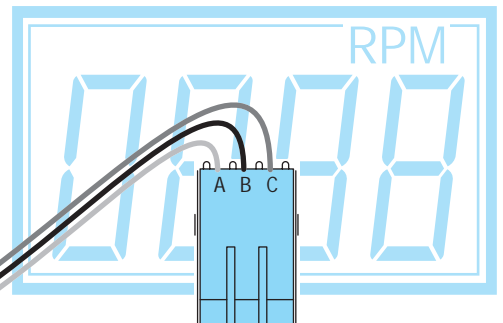
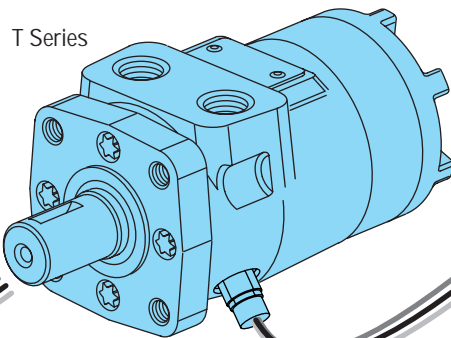
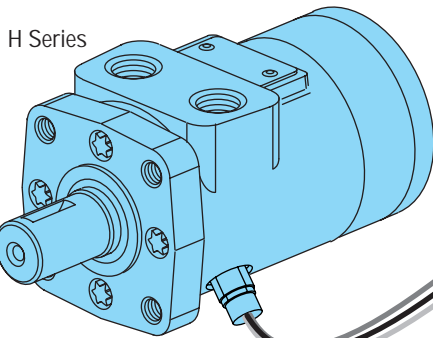

Note: The speed sensor option does NOT include read-out display. Possible sources for read-out display include: Eaton Corporation Durant Products 901 South 12 Street Watertown, WI 57094 — Phone 1-800-289-3866.

# Fluid Recommendations

## H, S, and T Series

### Introduction

The ability of Eaton hydraulic components to provide the desired performance and life expectancy depends largely on the fluid used. The purpose of this section is to provide readers with the knowledge required to select the appropriate fluids for use in systems that employ Eaton hydraulic components.

One of the most important characteristic to consider when choosing a fluid to be used in a hydraulic system is viscosity. Viscosity choice is always a compromise; the fluid must be thin enough to flow easily but thick enough to seal and maintain a lubricating film between bearing and sealing surfaces. Viscosity requirements, see chart below.

### Viscosity and Temperature

Fluid temperature affects viscosity. In general, as the fluid warms it gets thinner and its viscosity decreases. The opposite is true when fluid cools. When choosing a fluid, it is important to consider the start-up and operating temperatures of the hydraulic system. Generally, the fluid is thick when the hydraulic system is started. With movement, the fluid warms to a point where a cooling system begins to operate. From then on, the fluid is maintained at the temperature for which the hydraulic system was designed. In actual applications this sequence varies; hydraulic systems are used in many environments from very cold to very hot. Cooling systems also vary from very elaborate to very simple, so ambient temperature may affect operating temperature. Equipment manufacturers who use Eaton hydraulic components in their products should anticipate temperature in their designs and make the appropriate fluid recommendations to their customers.

### Cleanliness

Cleanliness of the fluid in a hydraulic system is extremely important. Eaton recommends that the fluid used in its hydraulic components be maintained at ISO Cleanliness Code 18/13 per SAE J1165. This code allows a maximum of 2500 particles per milliliter greater than 5 µm and a maximum of 80 particles per milliliter greater than 15 µm. Cleanliness requirements for specific products are given in the table below. OEM's and distributors who use Eaton hydraulic components in their

products should provide for these requirements in their designs. A reputable filter supplier can supply filter information.

### Fluid Maintenance

Maintaining correct fluid viscosity and cleanliness level is essential for all hydraulic systems. Since Eaton hydraulic components are used in a wide variety of applications it is impossible for Eaton to publish a fluid maintenance schedule that would cover every situation. Field testing and monitoring are the only ways to get accurate measurements of system cleanliness. OEM's and distributors who use Eaton hydraulic components should test and establish fluid maintenance schedules for their products. These maintenance schedules should be designed to meet the viscosity and cleanliness requirements laid out in this document.

### Fluid Selection

Premium grade petroleum based hydraulic fluids will provide the best performance in Eaton hydraulic components. These fluids typically contain additives that are beneficial to hydraulic systems. Eaton recommends fluids that contain anti-wear agents, rust inhibitors, anti-foaming agents, and oxidation inhibitors. Premium grade petroleum based hydraulic fluids carry an ISO VG rating.

SAE grade crankcase oils may be used in systems that employ Eaton hydraulic components, but it should be noted that these oils may not contain all of the recommended additives. This means using crankcase oils may increase fluid maintenance requirements.

Hydraulic fluids that contain V.I. (viscosity index) improvers, sometimes called multi-viscosity oils, may be used in systems that employ Eaton hydraulic components. These V.I. improved fluids are known to "shear-down" with use. This means that their actual viscosity drops below the rated value. Fluid maintenance must be increased if V.I. improved fluids are used. Automotive automatic transmission fluids contain V.I. improvers.

Synthetic fluids may be used in Eaton hydraulic components. A reputable fluid supplier can provide information on synthetic fluids. Review applications that require the use of synthetic fluids with your Eaton representative.

Product Line	Viscosity		ISO Cleanliness Requirements
	Minimum	Best Range	
S Series and T Series	70 SUS 13 cSt	100-200 SUS 20-43 cSt	18/13
H Series	100 SUS 20 cSt	100-200 SUS 20-43 cSt	18/13

### Additional Notes:

- Fluids too thick to flow in cold weather start-ups will cause pump cavitation and possible damage. Motor cavitation is not a problem during cold start-ups.
- When choosing a hydraulic fluid, all the components in the system must be considered and the best viscosity range adjusted accordingly. For example, when a medium duty piston pump is combined with a Geroler motor the best viscosity range becomes 100 - 150 SUS [20 - 32 cSt] and viscosity should never fall below 70 SUS [13 cSt].

- If the natural color of the fluid has become black it is possible that an overheating problem exists.
- If the fluid becomes milky a water contamination problem may exist.
- Take fluid level reading when the system is cold.
- Contact your Eaton representative if you have specific questions about the fluid requirements of Eaton hydraulic components.

## Model Code for H Series Motors

The following 16-digit coding system has been developed to identify all of the configuration options for the H Series Motor. Use this model code to specify a motor with the desired features. All 16-digits of the code must be present when ordering. You may want to photocopy the matrix below to ensure that each number is entered in the correct box.

### Model Code — H Series Spool Valve Motors

1	2	3	4	5	6	7	8	9	10	11	12	13	14	15	16
M	0	H												0	0

**Position 1 Product Series**

M ..... Motor

**Position 2, 3 H Series**

0H ..... H Series

**Position 4, 5 Displacement cm<sup>3</sup>/r [in<sup>3</sup>/r]**

02 ..... 36 [ 2.2]\*

03 ..... 46 [ 2.8]

04 ..... 59 [ 3.6]\*

05 ..... 74 [ 4.5]

06 ..... 97 [ 5.9]

07 ..... 120 [ 7.3]

09 ..... 146 [ 8.9]

10 ..... 159 [ 9.7]

11 ..... 185 [11.3]

14 ..... 231 [14.1]

18 ..... 293 [17.9]

23 ..... 370 [22.6]

45 ..... 739 [45.1]

**Position 6 Mounting Flange**

A ..... 2 Bolt (Standard) 82,6 [3.25] Pilot Dia. and 13,59 [ .535] Dia. Mounting Holes 106,2 [4.18] Dia. B.C.

B ..... 4 Bolt (Standard) 44,4 [1.75] Pilot Dia. and 3/8-16 Mounting Holes 82,6 [3.25] Dia. B.C.

E ..... 4 Bolt (Standard) 44,4 [1.75] Pilot Dia. and M10 x 1,5 Mounting Holes 82,6 [3.25] Dia. B.C.

H ..... 2 Bolt (Std.) 101,6 [4.00] Pilot Dia. and 14,35 [ .565] Dia. Mounting Holes 146,0 [5.75] Dia. B.C. (SAE B)

K ..... 4 Bolt Magneto 82,6 [3.25] Pilot Dia. and 13,59 [ .535] Dia. Mounting Holes 106,2 [4.18] Dia. B.C.

**Position 7, 8 Output Shaft**

01 ..... 1 inch Dia. Straight with Woodruff Key and 1/4-20 Threaded Hole

02 ..... 1 inch Dia. SAE 6B Splined with 1/4-20 Threaded Hole

07 ..... 1 inch Dia. Straight with 7,9 [ .31] Dia. Crosshole 11,2 [ .44] from End

08 ..... 1 inch Dia. Straight with 10,2 [ .40] Dia. Crosshole 15,7 [ .62] from End and 1/4-20 Threaded Hole

16 ..... 7/8 inch Dia. SAE B 13T Splined

17 ..... 7/8 inch Dia. SAE B Straight with Square Key

18 ..... 1 inch Dia. Tapered with Woodruff Key and Nut

24 ..... 25mm Dia. Straight with 8mm Key and 8mm x 1,2 Threaded Hole

27 ..... 1 inch Dia. Straight with Woodruff Key and 1/4-20 Threaded Hole (Plated for Corrosion Protection)

29 ..... 25mm Dia. Straight with 8mm x 1.2 Threaded Hole (Plated for Corrosion Protection)

32 ..... 1 inch Dia. Straight with 10,2 [ .40] Dia. Crosshole 15,7 [ .62] from End and 1/4-20 Threaded Hole (Plated...)

33 ..... 1 inch Dia. Tapered with Woodruff Key and Nut (Plated for Corrosion Protection)

**Position 9 Port Type**

A ..... 7/8-14 O-ring

B ..... 1/2-14 NPTF

C ..... Manifold (5/16-18 Mounting Threads)

D ..... Manifold (M8 x 1,25 Mounting Threads)

E ..... G 1/2 (BSP)

G ..... 3/4-16 End Ported

K ..... G 1/2 (BSP) End Ported

**Position 10 Case Drain**

0 ..... No Case Drain

1 ..... 7/16-20 O-ring Port End Cap

2 ..... G 1/4 (BSP) End Cap

**Position 11, 12 Special Features (Hardware)**

00 ..... None

AA ..... Free Running Gerotor

AB ..... Low Speed Valve

AC ..... Viton Shaft Seal

BW ..... Internal Check Valves

BZ ..... Speed Sensor

AM ..... Free Running Gerotor, Low Speed Valve

DS ..... High Pressure Shaft Seal

**Position 13 Special Features (Assembly)**

0 ..... None

1 ..... Reverse Rotation

2 ..... Flange Rotated 90°

**Position 14 Paint/Special Packaging**

0 ..... No Paint

A ..... Painted Low Gloss Black (Standard)

D ..... Corrosion Protected

**Position 15 Eaton Assigned Code when Applicable**

0 ..... Assigned Code

**Position 16 Eaton Assigned Design Code**

0 ..... Design Code

\*The H Series motors with displacement code "02" or "04" must also specify free running gerotor (option "AA" in positions 11, 12).

# Model Code for S Series Motors

The following 16-digit coding system has been developed to identify all of the configuration options for the S Series Motor. Use this model code to specify a motor with the desired features. All 16-digits of the code must be present when ordering. You may want to photocopy the matrix below to ensure that each number is entered in the correct box.

## Model Code — S Series Spool Valve Motors

1	2	3	4	5	6	7	8	9	10	11	12	13	14	15	16
M	0	S												0	0

**Position 1 Product Series**

M ..... Motor

**Position 2, 3 S Series**

0S ..... S Series

**Position 4, 5 Displacement cm<sup>3</sup>/r [in<sup>3</sup>/r]**

04 ..... 59 [ 3.6]

05 ..... 74 [ 4.5]

06 ..... 97 [ 5.9]

07 ..... 120 [ 7.3]

09 ..... 146 [ 8.9]

10 ..... 159 [ 9.7]

11 ..... 185 [11.3]

10 ..... 159 [ 9.7]

14 ..... 231 [14.1]

18 ..... 293 [17.9]

23 ..... 370 [22.6]

**Position 6 Mounting Flange**

A ..... 2 Bolt (Standard) 82,6 [3.25] Pilot Dia. and 13,59 [.535] Dia. Mounting Holes 106,2 [4.18] Dia. B.C.

B ..... 4 Bolt (Standard) 44,4 [1.75] Pilot Dia. and 3/8-16 Mounting Holes 82,6 [3.25] Dia. B.C.

E ..... 4 Bolt (Standard) 44,4 [1.75] Pilot Dia. and M10 x 1,5 Mounting Holes 82,6 [3.25] Dia. B.C.

H ..... 2 Bolt (Std.) 101,6 [4.00] Pilot Dia. and 14,35 [.565] Dia. Mounting Holes 146,0 [5.75] Dia. B.C. (SAE B)

K ..... 4 Bolt Magneto 82,6 [3.25] Pilot Dia. and 13,59 [.535] Dia. Mounting Holes 106,2 [4.18] Dia. B.C.

**Position 7, 8 Output Shaft**

01 ..... 1 inch Dia. Straight with Woodruff Key and 1/4-20 Threaded Hole

02 ..... 1 inch Dia. SAE 6B Splined with 1/4-20 Threaded Hole

07 ..... 1 inch Dia. Straight with 7,9 [.31] Dia. Crosshole 11,2 [.44] from End

08 ..... 1 inch Dia. Straight with 10,2 [.40] Dia. Crosshole 15,7 [.62] from End and 1/4-20 Threaded Hole

16 ..... 7/8 inch Dia. SAE B 13T Splined

17 ..... 7/8 inch Dia. SAE B Straight with Square Key

18 ..... 1 inch Dia. Tapered with Woodruff Key and Nut

24 ..... 25mm Dia. Straight with 8mm Key and 8mm x 1.2 Threaded Hole

27 ..... 1 inch Dia. Straight with Woodruff Key and 1/4-20 threaded Hole (Coated for Corrosion Protection)

**Position 9 Port Type**

A ..... 7/8-14 O-ring

B ..... 1/2-14 NPTF

C ..... Manifold (5/16-18 Mounting Threads)

D ..... Manifold (M8 x 1,25 Mounting Threads)

E ..... G 1/2 (BSP) End Cap

**Position 10 Case Drain**

0 ..... No Case Drain

1 ..... 7/16-20 O-ring Port End Cap

2 ..... G 1/4 (BSP) End Cap

**Position 11, 12 Special Features (Hardware)**

00 ..... None

AB ..... Low Speed Valve

AC ..... Viton Shaft Seal

BZ ..... Speed Sensor

DS ..... High Pressure Shaft Seal

**Position 13 Special Features (Assembly)**

0 ..... None

1 ..... Reverse Rotation

2 ..... Flange Rotated 90°

**Position 14 Paint/Special Packaging**

0 ..... No Paint

A ..... Painted Low Gloss Black (Standard)

D ..... Corrosion Protected

**Position 15 Eaton Assigned Code when Applicable**

0 ..... Assigned Code

**Position 16 Eaton Assigned Design Code**

0 ..... Design Code

# Model Code for T Series Motors

The following 16-digit coding system has been developed to identify all of the configuration options for the T Series Motor. Use this model code to specify a motor with the desired features. All 16-digits of the code must be present when ordering. You may want to photocopy the matrix below to ensure that each number is entered in the correct box.

## Model Code — T Series Spool Valve Motors

1	2	3	4	5	6	7	8	9	10	11	12	13	14	15	16
M	0	T												0	0

**Position 1 Product Series**

M ..... Motor

**Position 2, 3 T Series**

OT ..... T Series

**Position 4, 5 Displacement cm<sup>3</sup>/r [in<sup>3</sup>/r]**

02 ..... 36 [ 2.2]

03 ..... 49 [ 3.0]

04 ..... 66 [ 4.0]

05 ..... 80 [ 4.9]

06 ..... 102 [ 6.2]

08 ..... 131 [ 8.0]

10 ..... 157 [ 9.6]

12 ..... 195 [11.9]

15 ..... 244 [14.9]

19 ..... 306 [18.7]

23 ..... 370 [22.6]

**Position 6 Mounting Flange**

A ..... 2 Bolt (Standard) 82,6 [3.25] Pilot Dia. and 13,59 [.535] Dia. Mounting Holes 106,2 [4.18] Dia. B.C.

B ..... 4 Bolt (Standard) 44,4 [1.75] Pilot Dia. and 3/8-16 Mounting Holes 82,6 [3.25] Dia. B.C.

E ..... 4 Bolt (Standard) 44,4 [1.75] Pilot Dia. and M10 x 1,5 Mounting Holes 82,6 [3.25] Dia. B.C.

H ..... 2 Bolt (Std.) 101,6 [4.00] Pilot Dia. and 14,35 [.565] Dia. Mounting Holes 146,0 [5.75] Dia. B.C. (SAE B)

K ..... 4 Bolt Magneto 82,6 [3.25] Pilot Dia. and 13,59 [.535] Dia. Mounting Holes 106,2 [4.18] Dia. B.C.

**Position 7, 8 Output Shaft**

01 ..... 1 inch Dia. Straight with Woodruff Key and 1/4-20 Threaded Hole

02 ..... 1 inch Dia. SAE 6B Splined with 1/4-20 Threaded Hole

07 ..... 1 inch Dia. Straight with 7,9 [.31] Dia. Crosshole 11,2 [.44] from End

08 ..... 1 inch Dia. Straight with 10,2 [.40] Dia. Crosshole 15,7 [.62] from End and 1/4-20 Threaded Hole

16 ..... 7/8 inch Dia. SAE B 13T Splined

17 ..... 7/8 inch Dia. SAE B Straight with Square Key

18 ..... 1 inch Dia. Tapered with Woodruff Key and Nut

24 ..... 25mm Dia. Straight with 8mm Key and 8mm x 1.2 Threaded Hole

27 ..... 1 inch Dia. Straight with Woodruff Key and 1/4-20 Threaded Hole (Plated for Corrosion Protection)

**Position 9 Port Type**

A ..... 7/8-14 O-ring

B ..... 1/2-14 NPTF

C ..... Manifold (5/16-18 Mounting Threads)

D ..... Manifold (M8 x 1,25 Mounting Threads)

E ..... G 1/2 (BSP) End Cap

**Position 10 Case Drain**

0 ..... No Case Drain

1 ..... 7/16-20 O-ring Port End Cap

2 ..... G 1/4 (BSP) End Cap

**Position 11, 12 Special Features (Hardware)**

00 ..... None

AB ..... Low Speed Valve

AC ..... Viton Shaft Seal

BW ..... Internal Check Valves

BZ ..... Speed Sensor

DS ..... High Pressure Shaft Seal

**Position 13 Special Features (Assembly)**

0 ..... None

1 ..... Reverse Rotation

2 ..... Flange Rotated 90°

**Position 14 Paint/Special Packaging**

0 ..... No Paint

A ..... Painted Low Gloss Black (Standard)

D ..... Corrosion Protected

**Position 15 Eaton Assigned Code when Applicable**

0 ..... Assigned Code

**Position 16 Eaton Assigned Design Code**

0 ..... Design Code



Information contained in this catalog is accurate as of the publication date and is subject to change without notice. Performance values are typical values. Customers are responsible for selecting products for their applications using normal engineering methods.

GREAT LAKES FLUID POWER  
4170 36TH STREET SE  
GRAND RAPIDS, MI 49512  
Telephone: 800-968-0188  
Fax: 616-949-6598  
<http://www.charlynn.com>



Quality System Certified  
Products in this catalog are  
manufactured in an  
ISO-9001-certified site.